

**TEI/SJSU HIGH-TECH TAX INSTITUTE**  
**U.S. INTERNATIONAL TAX DEVELOPMENTS**

**November 9, 2015**

by

**James P. Fuller**  
**Fenwick & West LLP**  
**Mountain View, California**

I.	Foreign Tax Credits .....	1
II.	Section 482.....	13
III.	Subpart F.....	36
IV.	Partnerships.....	59
V.	Section 367.....	64
VI.	Other Developments .....	82
VII.	Treaties.....	99
VIII.	Inversions.....	121
IX.	Administration’s 2016 Budget.....	124
X.	BEPS: Final Reports .....	136
XI.	BEPS: Revisions to the OECD’s Transfer Pricing Guidelines.....	161

I. FOREIGN TAX CREDITS.

A. FTC Splitter Regulations.

1. Treasury and the IRS finalized the foreign tax credit splitter regulations. A public hearing was not requested and none was held, but the IRS and Treasury received a number of written comments. The proposed regulations under § 909 were adopted as amended by the Treasury Decision we will discuss below. The Treasury Decision also adopted the proposed regulations under § 704 (dealing with splitters in the context of partnerships) without amendment.
2. Reverse Hybrid Splitter Arrangements. A reverse hybrid splitter arrangements exists with respect to a reverse hybrid entity when a payor pays or accrues foreign income taxes with respect to the income of the reverse hybrid. The split taxes are the taxes paid or accrued with respect to the income of the reverse hybrid. The related income with respect to the split taxes is the earnings and profits of the reverse hybrid attributable

to the activities of the reverse hybrid that gave rise to the foreign taxable income on which the split taxes were paid or accrued.

- (a) A comment indicated there is some lack of clarity regarding the amount of related income with respect to a reverse hybrid splitter arrangement in a case in which the reverse hybrid subsequently incurs a loss, causing its earnings and profits to fluctuate over multiple taxable years. Treasury and the IRS agreed with this comment, and added two new examples.
- (b) In the first example, the reverse hybrid earns 200 of income on which it pays 60 of tax. In year 2, the reverse hybrid earns no income and incurs no losses or expenses. At the end of year 2, the reverse hybrid distributes 100 to its shareholder. This is a splitter arrangement, the taxes are split taxes, and a credit for those taxes is suspended. In year 2, 50% of the taxes, a ratable portion of the split taxes, can be taken into account.
- (c) In the Example 2, the facts are the same as in Example 1, except that in year 2 the reverse hybrid has a 100 loss, which it may not carryback to year 1. At the end of year 2, the reverse hybrid distributes 100 to its shareholder. The total related income of the reverse hybrid is reduced to a 100 because of its year 2 loss. In year 2, 100 was distributed, so 100% of the taxes can be taken into account.

3. Loss-Sharing Splitter Arrangements. A splitter arrangement exists to the extent that the “usable shared loss” of a “U.S. combined income group,” which is an individual or corporation and all entities with which it combined items of income and expense under U.S. federal income tax law, is used to offset federal taxable income of another U.S. combined group. A usable shared loss is defined as a shared loss of a U.S. combined group that could be used under foreign law to offset the group’s own income.

- (a) A comment requested that the definition of usable shared loss be clarified to exclude any shared loss that could not be used within the U.S. combined income group in a foreign taxable year but that could be used within a group by carrying the loss either forward or back to a different foreign tax year. Treasury and the IRS agree that the usable shared loss definition should not require a U.S. combined group to carry forward losses because it will not necessarily be foreseeable whether the group will have sufficient foreign taxable income in a future taxable year to use a loss that cannot be used currently or carried back within the group. Accordingly, the regulations modify the definition to clarify that a usable shared loss is a shared loss that could be used under foreign

tax law to offset income of the U.S. combined group in a current or previous foreign taxable year.

- (b) Two additional comments were not adopted, but a question has arisen, states the preamble, about what references to “income” are in Temp. Treas. Reg. § 1.909-2T(b)(2). The question: are these references intended to refer to income for U.S. federal income tax purposes or to income for purposes of foreign tax law? The final regulations clarify that the reference to the term “income” of that U.S. combined income group refers to income for purposes of foreign law.

4. Hybrid Instrument Splitter Agreements. There is a U.S. equity hybrid instrument splitter arrangement if payments or accruals with respect to a U.S. equity hybrid instrument (1) give rise to foreign income taxes paid or accrued by the owner of the instrument, (2) are deductible by the issuer under the laws of its foreign jurisdiction, and (3) do not give rise to income for U.S. federal income tax purposes.

- (a) The preamble states that a question has arisen as to whether there is a splitter arrangement if an accrual for foreign law purposes with respect to a U.S. equity hybrid instrument does not give rise to income under U.S. law but a separate payment of the accrued amount is made that gives rise to income under U.S. law equal to all or a portion of the amount of accrual. The preamble states that the reference to “payments or accruals” created confusion regarding the effect of payment.
- (b) The final regulations are clarified to provide that if an accrual under foreign law with respect to a U.S. equity hybrid instrument give rise to a foreign-law deduction by the issuer, then regardless of whether a payment is made on the instrument, a splitter arrangement exists whenever an accrual gives rise to the imposition of foreign income taxes on the instrument owner without giving rise to income under U.S. federal income tax law.
- (c) Any actual payment of the accrued amount, whether or not it is made periodically under the terms of the instrument, does not prevent the hybrid instrument from being a splitter arrangement. The payments, however, will then be treated as a distribution of related income to the extent the regulations otherwise apply.

5. Mechanical Rules for Tracking Related Income and Split Taxes. A comment recommended that the regulations should generally provide additional mechanical rules for tracking related income. Treasury and the IRS recognize there are a number of mechanical issues related to tracking related income and split taxes that were not fully addressed in the

temporary regulations. The preamble states that other mechanical issues are under consideration and will be addressed in future guidance. Other comments with respect to the mechanical rules for tracing related income were not adopted.

6. Section 381 Transactions. One comment incorrectly interpreted the temporary regulations as providing that when a payor § 902 corporation with suspended split taxes combines with the covered person with the related income in a transaction described in § 381, all related income is treated as taken into account even if the full amount of related income is not reflected in the earnings and profits of the payor § 902 corporation as a result of the transaction.
  - (a) Treasury and the IRS did not intend for a transaction described under § 381 to result in the unsuspension of split taxes if the transaction does not cause the payor of the split taxes to take into account earnings and profits of the covered person equal to the amount of related income specified in the relevant splitter arrangement definition.
  - (b) Accordingly, the final regulations clarify that split taxes are unsuspended only when the appropriate amount of related income is taken into account by the payor § 902 corporation either as a result of a distribution or inclusion out of the earnings and profits of the covered person as a result of the combination of the payor § 902 corporation and the covered person in a transaction described in § 381.
7. Additional Splitter Arrangement Fact Patterns. One comment recommended that the U.S. debt hybrid instrument splitter arrangement definition be expanded to include certain fact patterns in which the instruments owner is not related to the issuer of the instrument. Treasury and the IRS concluded that it is not appropriate at this time to extend the existing splitter arrangement list to include transactions between unrelated parties and did not adopt the comment. The preamble states that Treasury and the IRS continue, however, to consider other arrangements that inappropriately separate foreign income taxes from related income, and the circumstances under which a splitter arrangement described in regulations or other guidance under § 902 should be applied to arrangements between unrelated persons.

B. Salem Financial.

1. *Salem Financial, Inc. v. United States* was generally affirmed on appeal. Salem financial is a subsidiary of BB&T, a financial holding company chartered under the laws of North Carolina. The case was on appeal from a Court of Federal Claims decision denying BB&T's claim for a refund of

taxes, interest and penalties. The Federal Circuit affirmed with respect to denial of the foreign tax credit and the assertion of penalties, but reversed in part with respect to a deduction for interest and remanded the case for further proceedings.

2. Salem Financial involved a STARS transaction which I will not describe here as STARS transactions are not new. That is, previous cases were already litigated. Essentially, Salem Financial, a U.S. bank placed assets in a trust in the context of a loan that was subject to U.K. tax and claimed a foreign tax credit for that tax. Barclays, a U.K. bank, also got benefits through that trust and made a payment to Salem Financial of approximately half of Barclays' U.K. tax benefit. This produced a lower cost of borrowing for Salem Financial. The question was whether Salem Financial could claim foreign tax credits for the tax.
3. The first issue was whether the trust transactions lacked economic reality, whether they lacked a bona fide business purpose, and whether they are the kinds of transactions with respect to which Congress intended to confer the benefit of the foreign tax credit provisions.
4. Initially, the government argued that the payments Barclays made to Salem Financial, which were set to equal 51% of the U.K. taxes paid by the trust, "in substance" were rebates of the U.K. tax that was paid by BB&T on income from the assets that BB&T contributed to the trust. The court concluded that those payments should not be characterized as tax rebates but rather constituted income to BB&T.
5. The court then addressed the government's argument that BB&T realized no profit from the trust transactions absent the \$500 million in foreign tax credits generated by the transaction because the payments by Barclays must be offset against the trust's U.K. taxes that were paid by BB&T. BB&T contended that the government was wrong in seeking to have the trust's U.K. taxes treated as an item of expense, citing certain other circuit courts' holdings. The court stated, however, that its precedent, like the approach of several other courts, supported the government's argument, *i.e.*, to assess a transaction's economic reality, and in particular is profit potential, the analysis must be done independent of the expected tax benefits.
6. In this case, stated the court, BB&T incurred a large foreign tax expense to obtain only a small income amount. The trust transaction therefore was profitless before taking into account BB&T's expected foreign tax credit benefits.
7. However, the court disagreed with the government's contention that a transaction's lack of profit potential before taking into account U.S. tax

benefits conclusively established that the transaction lacked economic reality.

8. The court stated it is critical to identify transactions lacking economic reality, *i.e.*, those that do not alter the taxpayer's economic position in any meaningful way apart from their tax consequences, typically entailing no risk and no significant possibility of profit other than as a result of tax considerations.
9. While looking to the potential for economic profit is useful, the Supreme Court has cautioned that there is "no simple device available to peel away the form of [a] transaction to reveal its substance." Therefore, stated the Federal Circuit, although inquiring into post-foreign-tax profit can be a useful tool for examining the economic reality of a transaction, the court believed that a transaction that fails the profit test is not necessarily deemed a sham.
10. In this case, the trial court's finding that the trust transaction lacked economic substance was supported by more than just the absence of a prospect for profit. The trial court found that the trust transaction consisted of "three principal circular cash flows," which, apart from their intended tax consequences, had no real economic effect.
11. The court agreed with the trial court that the trust transaction was a contrived transaction performing no economic or business function other than to generate tax benefits.
12. The court then turned to the second element of the "economic substance" test: whether the STARS trust transaction, nonetheless had a bona fide business purpose. The trial court found that the STARS trust had no non-tax business purpose and that, instead, its sole function was to "self-inflict" U.S.-sourced BB&T income to tax in order to reap U.S. and U.K. tax benefits. The court stated that finding is amply supported by the evidence.
13. The court stated the evidence supports the trial court's finding that the STARS trust was a "prepackaged strategy" created to generate U.S. and U.K. tax benefits for BB&T and Barclays. Further, the payments by Barclays did not represent profit from any business activity. The payments were simply the means by which Barclays and BB&T shared the tax benefits of trust transaction. That is, the transaction that generated the income leading to the payment to BB&T involved no genuine business activities, and the transaction that produced the payment would not have been engaged in but for the system of taxes imposed by the U.S. and U.K. governments.

14. The court stated that it therefore sustained the trial court's finding that the STARS trust lacked a bona fide business purpose. Thus, the \$500 million of foreign tax credits were disallowed.
15. BB&T also sought to recover deductions for the interest it paid on the \$1.5 billion STARS loan. That is, there was a loan component to the transaction. The trial court disallowed the interest deductions, holding that the loan, like the trust, lacked economic substance. The interest deductions were in the amount of approximately \$75 million.
16. The court stated that incorporating a loan component into STARS to give the entire transaction the appearance of "low cost financing" no doubt was one of the intended purposes of the loan. However, the structure of the STARS loan appeared to be straightforward.
17. The court stated that while it may be true that the loan operated partly to camouflage the payments by Barclays to BB&T, it also resulted in a substantial change in BB&T's economic position. As a result of the loan transaction, BB&T obtained the unrestricted access to \$1.5 billion in loan proceeds.
18. In the *Bank of New York Mellon* case, which involved a similar STARS trust and loan transaction, the Tax Court in its initial opinion did not separately address the question whether the interest on the loan component of the transaction was deductible. On reconsideration, however, the court held that the interest on the loan component was deductible.
19. The Federal Circuit agreed with the Tax Court's analysis of the loan component of the STARS transaction. Accordingly, the court held that the loan portion of the transaction satisfied the economic substance test and that BB&T was entitled to claim interest deductions for the interest it paid on the loan.
20. The final issue on appeal was whether the trial court properly upheld the \$112 million in penalties asserted by the government. BB&T contended that it had reasonable cause for the underpayments because it reasonably relied on the favorable tax opinions of a law firm and received additional supportive advice from its accounting-firm auditor. On appeal, BB&T no longer argued that it reasonably relied on the advice it received from KPMG, the principal marketer of STARS.
21. The trial court found that BB&T's reliance on the law firm's opinion was unreasonable because the law firm had an inherent conflict of interest of which BB&T knew or should have known. That finding was not clearly erroneous. BB&T had selected that firm on the recommendations of KPMG, the principal marketer of STARS.

22. The trial court also found that the auditor's participation did not give BB&T a reasonable basis for believing that its tax position was sound, because the accounting firm provided no opinion to BB&T. That finding also was not erroneous. Moreover, the accounting firm ultimately arrived at a "less than should" level of comfort that the IRS would accept the STARS transaction.
23. The trial court stated that BB&T's reliance on its advisor's opinions was unreasonable for the additional reason that it should have known that the STARS transaction was too good to be true.
24. Accordingly, the court concluded that the trial court did not err in imposing the accuracy-related penalties on BB&T. The amount of the penalties, however, will require a reassessment, as the appellate court found BB&T was entitled to claim interest deductions for the interest it paid on the STARS loan.

C. BNY/AIG.

1. The Second Circuit affirmed the lower courts in *Bank of New York Mellon v. Commissioner* and *American International Group v. United States* regarding applying the economic substance doctrine to transactions involving foreign tax credits. \_\_\_ F.3d \_\_\_ (2d Cir. 2015). The Tax Court in *Bank of New York Mellon* ("BNY") considered the effect of foreign taxes in its pre-tax analysis and denied the claimed foreign tax credits as lacking economic substance, but allowed interest expense deductions for the loan associated with the transactions. The district court in *AIG* held that the economic substance doctrine applies to transactions involving foreign tax credits generally and that foreign taxes are to be included in calculating pre-tax profit. In *BNY*, \$215 million in deficiencies were asserted by the IRS. In *AIG*, a tax refund of \$300 million is sought.
2. The court stated that entitlement to foreign tax credits is predicated on a valid transaction. To be "valid" and not just a "sham," a transaction must involve more than tax benefits: it must have independent economic substance. Through the transactions at issue, the taxpayers asserted they were able to borrow funds at economically favorable rates below LIBOR and invested the funds at rates above LIBOR.
3. AIG claimed that the cross-border transactions had economic substance because they were expected to generate a pre-tax profit of at least \$168 million for AIG over the life of the transactions. To reach this number, AIG calculated pre-tax profit by taking a special purpose vehicle's (SPV) investment income and subtracting only AIG's operating expenses and obligations to the foreign lending banks. Thus, in calculating pre-tax profit, AIG ignored (1) the foreign tax paid by the SPV, (2) the U.S. tax



paid by AIG on the SPV's investment income, and (3) the value of the foreign tax credits claimed by AIG.

4. *BNY* involved a STARS transaction. The Tax Court bifurcated its analysis of the STARS trust structure and the \$1.5 billion loan and found: (1) foreign taxes but neither loan proceeds nor the tax-spread should be considered in the pre-tax analysis of economic substance; (2) the STARS trust transaction lacked economic substance as BNY had no purpose in entering the transaction except tax avoidance; (3) the tax-spread should be included in BNY's taxable income rather than considered a component of loan interest, as it served as a device to monetize anticipated foreign tax credits and (4) all expenses incurred from the STARS transactions, including interest expense from the \$1.5 billion loan, were not deductible.
5. In a supplemental opinion in *BNY*, the Tax Court held that (1) the tax-spread was not includible in BNY's income because it was part of the trust transaction that was disregarded for tax purposes for lacking economic substance; and (2) BNY was entitled to interest expense deductions because the \$1.5 billion loan, bifurcated from the STARS trust transaction, had independent economic substance.
6. The Second Circuit said that substance rather than form determines tax consequences. The court also said that the economic substance doctrine exists to provide courts a "second look" to ensure that particular uses of tax benefits comply with Congress's purpose in creating that benefit. The court also found no support for the taxpayers' contention of foreign tax credits, by their nature, are not reviewable for economic substance. The court also noted the recent codification of economic substance by Congress, and Treasury and the IRS's issuance of new regulations disallowing foreign tax credits associated with STARS and "other similarly convoluted transactions designed to take advantage of foreign tax credits."
7. The court noted the Federal Circuit's decision in *Salem Financial, Inc. v. United States*, \_\_\_ F.3d \_\_\_ (Fed. Cir. 2015), a case involving the same STARS transaction at issue in *BNY*. The Federal Circuit concluded that foreign taxes are economic costs that are properly deducted in assessing profitability for the purposes of economic substance. The Federal Circuit held, however, that this lack of post-foreign-tax profit did not conclusively establish that a transaction lacks objective economic substance. The Federal Circuit ultimately held that STARS lacked objective economic substance, based on both the lack of post-foreign-tax profit and on the circular cash flows through the trust whose only purposes was generating tax benefits.
8. In factually different contexts, the Fifth and Eighth circuits have taken a different approach to assessing objective economic substance, holding that

foreign taxes are not economic costs and should not be deducted from pre-tax profit. *Compaq v. Commissioner*, 277 F.3d 778 (5<sup>th</sup> Cir. 2001) and *IES Industries v. United States*, 253 F.3d 350 (8<sup>th</sup> Cir. 2001).

9. The Second Circuit said that it agreed with the Tax Court in *BNY* and the Federal Circuit in *Salem*. The purpose of calculating pre-tax profit in this context is not to perform mere financial accounting, subtracting costs from revenue on a spreadsheet: it is to discern, as a matter of law, whether a transaction meaningfully alters a taxpayer's economic position other than with respect to tax considerations.
10. The court stated that the purpose of the foreign tax credit is to facilitate global commerce by making the IRS indifferent as to whether a business transaction occurs in this country or in another, not to facilitate international tax arbitrage. The court stated that the trust transaction in *BNY* had little to no potential for economic return apart from the tax benefits. When the record in *AIG* is viewed most favorably to the government (*AIG* moved for summary judgment), a reasonable factfinder could reach the same conclusion as to the cross-border transactions. Accordingly, the court held that foreign taxes are economic costs for purposes of the economic substance doctrine and thus should be deducted from profit before calculating pre-tax profit.
11. The objective economic substance inquiry, however, does not end at profit, as a legitimate transaction could conceivably lack economic profit. There is no simple device to peel away the form of a transaction and to reveal its substance. A court should also look to the overall economic effect of the transaction in determining objective economic substance. In conducting this inquiry, the court agreed with the Tax Court that "economic benefits that would result independent of a transaction do not constitute a non-tax benefit for purposes of testing its economic substance."
12. The court also must look to the subjective business purpose of a transaction to determine whether it has economic substance. A court must ask whether the taxpayer has a legitimate, non-tax business purpose for entering into the transaction. The business purpose inquiry concerns the motives of the taxpayer in entering into the transaction; it asks whether the taxpayer's "sole motivation" for entering a transaction was to realize tax benefits. The focus is the reasonableness of the transaction and can be articulated as: would a "prudent investor," absent tax benefits, have made the deal. The court concluded that *BNY*'s *STARS* transaction failed this test.
13. The court also felt that it was appropriate to bifurcate the transaction and the loan, as the Tax Court did. The loan, independent of the trust structure, had economic substance.

D. Lehman Brothers.

1. Lehman Brothers asserted the IRS wrongfully disallowed certain foreign tax credits claimed by Lehman. The issue was decided for the government under § 901(k). *Lehman Brothers Holdings, Inc. v. United States*, \_\_\_\_ F. Supp. \_\_\_\_ (SDNY 2015).
2. Lehman contended it was entitled pursuant to the U.S.-U.K. treaty to claim foreign tax credits for taxes imposed by the U.K. on so-called substitute dividend payments received by Lehman from one of its U.K. subsidiaries under the terms of “hundreds” of stock loan transactions. That is, the parties’ sole dispute was a legal one: whether the treaty causes a substitute dividend payment -- which is not a dividend under U.S. law -- to be treated as a dividend for U.S. foreign tax credit purposes and thus whether § 901(k), which is a “limitation of the law of the United States” applicable to dividends, applies to deny the foreign tax credits claimed by Lehman with respect to the substitute dividend payments.
3. Lehman entered into hundreds of “stock loan transactions” with its U.K. subsidiary. In each stock loan transaction, Lehman borrowed shares of stock in U.K. corporations from various third-party U.S.-based lenders “over” the stocks’ respective dividend record dates, the dates on which the record owners of the stock became entitled to receive dividends declared by the companies. Within 1-2 business days of borrowing the U.K. companies’ stock, Lehman “on-lent” the stock to its U.K. subsidiary. When the U.K. corporations that issued the stock paid dividends to the owners of the stock, Lehman’s U.K. subsidiary, rather than Lehman received the dividends.
4. The borrower -- in this case Lehman’s U.K. subsidiary -- received the dividend and then was required, pursuant to the terms of the stock loan transactions, to make a substitute dividend payment to the immediate prior lender in an amount equal to the dividend. Thus, in the stock loan transactions at issue, whenever a dividend was paid to Lehman’s U.K. subsidiary on borrowed stock, the U.K. subsidiary made a substitute dividend payment to Lehman. Lehman, in turn, made a substitute dividend payment to the original U.S.-based lender on the same business day.
5. The court used the following example. Lehman treated as taxable income the amount of \$10 when the substitute dividend payment was \$90, *i.e.*, the \$90 substitute dividend payment received by Lehman from its U.K. subsidiary, plus a \$10 U.K. tax payment, minus the \$90 substitute dividend payment paid by Lehman to its third-party lender. The U.S. tax on \$10 (at the 35% corporate tax rate) was \$3.50. Against this amount, Lehman claimed a foreign tax credit of \$10 (*i.e.*, the amount of the U.K.

tax). This left a balance of \$6.50 in excess foreign tax credits which Lehman sought to use to offset other U.S. tax obligations.

6. The court stated that Lehman’s interpretation of the several treaty provisions runs contrary to an established canon of construction that “similar language contained within the same section of a [statute or treaty] must be accorded a consistent meaning.” The court cited *National Credit Union Administration v. First National Bank & Trust Co.*, 522 U.S. 479, 501 (1998); and *Sacirbey v. Guccione*, 589 F.3d 52, 66 (2d Cir. 2009) (“basic canons of statutory construction are equally applicable to interpreting treaties”).
7. The court stated that Lehman inconsistently “cherry picked” among various provisions of the treaty to achieve a desired tax result. That is, stated the court, by inconsistently interpreting the term dividend in the treaty, Lehman sought to obtain benefits provided for in the foreign tax credit provision while avoiding negative ramifications of other provisions (*i.e.*, the “limitations of U.S. law” on dividend-based foreign tax credits).
8. The court cited a 2006 chief counsel advice (CCA 200612013) which evaluated a taxpayer’s contention nearly identical to Lehman’s contention that “the treaty’s purported characterization of the substitute dividend payments and deemed refunds of ACT as dividends applies to allow it to claim foreign tax credits under the treaty for amounts deemed withheld from those payments, but is jettisoned for purposes of applying the statutory limitations on the foreign tax credit, such as § 901(k)...” The court stated that neither party seems to have cited to, much less discussed, this chief counsel advice in its briefs. The court stated that, while not binding on the court, the CCA’s thorough analysis of the U.K. treaty article was instructive.
9. The parties also had disagreed over the purpose of the stock borrowings. The government contended that the evidence on the economic purpose of the disputed trades would have shown that for almost all trades, Lehman had no reason to borrow the U.K. stock as it had no profitable use for it...and that the only reason Lehman entered into the trades was to claim that the treaty generated foreign tax credits that it could use to avoid paying U.S. tax on millions of dollars of unrelated profits. Lehman countered by stating that there are many uses of stock loan transactions, which it then enumerated on.
10. The court stated that its resolution of Lehman’s claim was based principally on the plain language of the treaty. The court stated that it was not based on the economic substance or purposes of the stock loan transactions.

11. Section 901(k)(1)(A)(ii) reads as follows: “In no event shall a [foreign tax] credit be allowed...for any withholding tax on a dividend with respect to stock in a corporation if...the recipient of the dividend is under an obligation...to make related payments with respect to positions in substantially similar or related property.”

## II. SECTION 482.

### A. APA Report for 2014.

1. The IRS completed 101 APAs in 2014, a decrease from the 145 completed in 2013, and the median completion time went up to 35.3 months from 32.7 months in 2013.
2. The APA report states that 108 applications were filed in 2014. Of the bilateral applications, 41% involve Japan, 12% Canada, and 10% the U.K. Thus, nearly two-thirds of the bilateral APA applications filed in 2014 involve these three countries. Similarly, of the bilateral APAs executed in 2014, 47% involved Japan, 15% Canada and 10% the U.K. These three countries thus represent nearly three quarters of the executed bilateral APAs in 2014.
3. Fifty-five percent of the APAs executed in 2014 involved foreign parent and U.S. subsidiary transactions. Thirty-one percent involved U.S. parent and foreign subsidiary transactions. The remaining 14% involved a U.S. company and its foreign branch, and a category described as “sister companies.” Thus, as in the past, there was a predominance of APAs involving foreign parent companies versus the category involving U.S. parent companies.
4. Most APAs had a five-year term. Some extended for six years or more.
5. CPM/TNMM was used in 78% of APAs involving tangible and intangible property, and 77% of APAs involving services. For tangible and intangible property, the profit level indicator “operating margin” was used in 88% of the APAs involving CPM and TNMM, and the operating profit to total services cost ratio (45%) and operating margin (47%) were the predominant profit level indicators used for services APAs involving CPM or TNMM.
6. More than 60% of the tested parties involved distribution or related functions (marketing and product support).

### B. Altera.

1. *Altera Corporation v. Commissioner*, 145 T.C. No. 3 (2015), is a follow-on to the *Xilinx v. Commissioner* case, 125 T.C. 37 (2005), *aff'd*, 598 F.3d 1191 (9<sup>th</sup> Cir. 2010).

2. In *Xilinx*, the Tax Court held that, under the § 1995 cost-sharing regulations, controlled entities entering into qualified cost-sharing agreements (“QCSAs”) need not share stock-based compensation costs because parties operating at arm’s length would not do so. In an effort to overrule *Xilinx*, Treasury and the IRS in 2003 issued Treas. Reg. § 1.482-7(d)(2). The 2003 regulation requires controlled parties entering into QCSAs to share stock-based compensation costs. *Altera v. Commissioner* addressed that regulation, and held that it was invalid.
3. The § 482 regulations provide that in determining the true taxable income of a controlled taxpayer, the standard to be applied in every case is that of an uncontrolled taxpayer dealing at arm’s length within another uncontrolled taxpayer. The arm’s length standard also is incorporated into numerous income tax treaties between the United States and foreign countries. In *Xilinx*, as noted, the Tax Court held that unrelated parties would not share the value of stock-based compensation in a cost-sharing arrangement. The Ninth Circuit, in *affirming*, held that the “all costs” requirement of the 1995 cost-sharing regulations was irreconcilable with the arm’s length standard.
4. In issuing the new regulations, Treasury and the IRS first published a proposed version of the regulations with a notice of proposed rulemaking and a notice of public hearing. At the hearing a number of persons testified, and many written comments were submitted.
5. Several of the commentators informed Treasury that they knew of no transactions between unrelated parties, including any cost-sharing arrangement, service agreement, or other contract, that required one party to pay or reimburse the other party for amounts attributable to stock-based compensation. Some comments were based on a survey of an association’s members. Some commentators represented that they had conducted multiple searches of electronic data gathering and found no cost-sharing agreements between unrelated parties in which the parties agreed to share either the exercise spread or grant date value of stock-based compensation.
6. Several commentators identified arms-length agreements in which stock-based compensation was not shared or reimbursed. Some cited the practice of the federal government, which regularly enters into cost-reimbursement contracts at arm’s length. They noted that federal acquisition regulations prohibit reimbursement of amounts attributed to stock-based compensation.
7. Treasury and the IRS nonetheless issued the regulation as a final regulation. The final rule explicitly required parties to QCSAs to share stock-based compensation costs. Treasury and the IRS also added sections to Treas. Reg. §§ 1.482-1(b)(2)(i) through 1.482-7(a)(3) to

provide that a QCSA produces an arm's-length result only if the parties' costs are determined in accordance with the final rule.

8. When Treasury and the IRS issued the final regulation, the government's files relating to the final rule did not contain any expert opinions, empirical data or published or unpublished articles, papers, surveys, or reports supporting a determination that the amounts attributable to stock-based compensation must be included in the cost rule of QCSAs to achieve an arm's-length result. Those files also did not contain any record that Treasury searched any data base that could have contained agreements between unrelated parties relating to joint undertakings with the provision of services. Treasury was also unaware of any written contract between unrelated parties that required one party to pay or reimburse the other party for amounts attributable to stock-based compensation.
9. The Court considered the applicable principles of Administrative Law, including especially the Administrative Procedure Act ("APA"). Pursuant to APA § 553, in promulgating regulations through informal rulemaking, an agency must (1) publish a notice of proposed rulemaking in the Federal Register; (2) provide interested parties an opportunity to participate in the rulemaking through submission of written data, views, or arguments with or without the opportunity for oral presentation; and (3) after consideration of the relevant matter presented incorporate in the rules adopted a concise general statement of their basis and purpose.
10. The Court stated that these requirements do not apply to interpretive rules (those which merely explain pre-existing substantive law), or when an agency for good cause finds--and incorporates its findings in the rules issued--that the notice and public procedure thereon are impracticable, unnecessary or contrary to the public interest. The regulations at issue, however, were legislative (substantive) regulations, *i.e.*, those that create rights, impose obligations, or effect a change in existing law.
11. The notice and comment requirements of APA § 553 are intended to assist judicial review as well as to provide fair treatment for persons affected by a rule. There must be an exchange of views, information, and criticism between interested parties and the agency. The opportunity to comment is meaningless unless the agency responds to significant points raised by the public. The failure to respond to comments is significant only insofar as it demonstrates that the agency's decision was not based on a consideration of the relevant factors.
12. Pursuant to APA § 706(2)(A), a court must hold unlawful and set aside agency action, findings and conclusions that it finds to be arbitrary, capricious and an abusive discretion or otherwise not in accordance with the law. A court's review under this standard is narrow and a court is not to substitute its judgment for that of the agency. *Motor Vehicle Mfrs.*

*Ass'n of the U.S. v. State Farm Mut. Auto. Ins. Co.*, 463 U.S. 29 (1983). A reviewing court, however, must ensure that the agency “engaged in reasoned decision making.” Under *State Farm*, normally an agency rule would be arbitrary and capricious if the agency has relied on factors which Congress has not intended it to consider, entirely failed to consider an important aspect of the problem, offered an explanation for its decision that runs counter to the evidence before the agency, or is so implausible that it could not be ascribed to a difference in view or the product of agency expertise.

13. The standard to be applied in every case under § 482 is that of an uncontrolled taxpayer dealing at arm’s length with another uncontrolled taxpayer. *Commissioner v. First Sec. Bank of Utah*, 405 U.S. 394 (1972) (quoting Treas. Reg. § 1.482-1(b)(1)); accord Treas. Reg. §§ 1.482-1(a)(1), (b)(1) and Treasury Department technical explanations of a number treaties.
14. The IRS countered that Treasury should be permitted to issue regulations modifying--or even abandoning--the arm’s-length standard. But the preamble to the final rule, stated the Court, did not justify the final rule on the basis of any modification or abandonment of the arm’s-length standard, and the IRS conceded that the purpose of § 482 is to achieve tax parity. The preamble to the regulation also did not dismiss any of the evidence submitted by commentators regarding unrelated party conduct as addressing an irrelevant or inconsequential factor. The Court stated that it did not decide whether Treasury would be free to modify or abandon the arm’s-length standard because it had not done so here.
15. The taxpayer contended that the final regulation is invalid because (1) it lacks a basis in fact, (2) Treasury failed rationally to connect the choice it made with the facts it found, (3) Treasury failed to respond to significant comments and (4) the final rule is contrary to the evidence before Treasury.
16. A court will generally not override an agency’s “reasoned judgment about what conclusions to draw from technical evidence or how to adjudicate between rival scientific or economic theories.” Treasury, however, failed to provide a reasoned basis for reaching the conclusions that support the regulation from any evidence in the administrative record. Indeed, every indication in the record pointed the other way. The Court concluded that by failing to engage in any fact finding, Treasury failed to examine the relevant data and it failed to support its belief that unrelated parties would share stock-based compensation with any evidence in the record. The Court also stated that the final rule was contrary to the evidence before Treasury when it issued the final rule.



17. Because the final regulation lacks a basis in fact, the Court held that Treasury failed to rationally connect the choice it made with the facts found, Treasury failed to respond to significant comments when it issued the final rule, and Treasury's conclusion that the final rule is consistent with the arm's-length standard was contrary to all of the evidence before it. Thus, the Court concluded that the final rule failed to satisfy the *State Farm's* reasoned decision making standard and therefore is invalid.
18. The Court closed with the statement that Treasury's *ipse dixit* conclusion coupled with its failure to respond to contrary arguments resting on solid data, epitomizes arbitrary and capricious decision making.
19. The decision was "reviewed by the Court," which means that all of the Tax Court's judges considered whether to join in with the Court's opinion, file concurring opinions, or dissent. All of the judges who participated agreed with the opinion of the Court. There were no dissenting opinions.
20. The term *ipse dixit* refers to an unsupported statement that rests solely on the authority of the individual who made it. The term describes a dogmatic statement that the speaker expects the listener to accept as valid.
21. In this regard, I cannot resist quoting a high-ranking government official as stating in 2008 "we can simply interpret arm's-length to mean what we think it should mean, and if we say it correctly, that is what it means." See Lee Sheppard, Tax Notes Int'l. Sept. 22, 2008, p. 970.
22. Unfortunately, this is the very issue that raises serious problems in BEPS. For example, the "special measures" exceptions to the arm's-length standard in BEPS has the U.S. government and taxpayers both concerned that it will lead to many *ipse dixit* pronouncements by foreign taxing authorities. Perhaps, these BEPS exceptions from the arm's length standard, instead of being referred to "special measures," should be called *ipse dixit* pronouncements. That's what they will be.

C. BMC: § 965/§ 482.

1. *BMC Software Inc. v. Commissioner*, \_\_\_ F.3d \_\_\_ (5<sup>th</sup> Cir.), reversed the Tax Court regarding the interrelationship of § 965 and a § 482-related repatriation under Rev. Proc. 99-32. The Fifth Circuit held that benefits under § 965 were not reduced by reason of the Rev. Proc. 99-32 repatriation closing agreement.
2. Congress enacted § 965 to encourage U.S.-based corporations to repatriate to the U.S., through dividends, funds sitting in the accounts of their foreign subsidiaries. To prevent abuse, Congress included an exception to § 965. The exception, set forth in § 965(b)(3), prevents U.S. corporations from making loans to their foreign subsidiaries to fund repatriated § 965 dividends. The Fifth Circuit referred to this as "round-tripping" and stated

that it would defeat Congress's purpose of inducing fresh investment of foreign cash into the United States.

3. The Court stated that when the IRS adjusts a corporation's transfer prices, the "primary adjustment" shifts taxable income from one related party to another, for example, from a foreign subsidiary to its U.S.-based parent company. "Secondary adjustments" also must be made so that the corporations' taxable income and cash accounts are not imbalanced. To make a secondary adjustment, stated the court, both parties revise their books to show that the foreign subsidiary holds cash that, due to the primary adjustment, is now effectively owned by the U.S.-based parent.
4. In 2006, BMC decided to repatriate funds pursuant to the § 965 rules. BMC correctly reported no related-party indebtedness on its 2006 tax return. In 2007, BMC and the IRS signed a transfer pricing closing agreement to reflect a § 482 adjustment. This was completely unrelated to the 2006 repatriation under § 965.
5. Pursuant to Treas. Reg. § 1.482-1(g)(3) and Rev. Proc. 99-32, BMC elected to treat the allocated amount as an accounts receivable, payable to the U.S. parent by the foreign subsidiary, with interest accruing from the date of deemed creation of the account. The subsidiary thereafter paid the account receivable and BMC was not taxed on receipt of those funds. The Rev. Proc. 99-32 closing agreement ("99-32 closing agreement") included introductory language stating that the agreement was "for federal income tax purposes." The parties also agreed that when the subsidiary paid off their newly created accounts receivable, the payments would be "free of the federal income tax consequences of the secondary adjustments that would otherwise result from the primary adjustment."
6. In 2011, four years after execution of the 99-32 closing agreement, the IRS issued to BMC a notice of tax deficiency based on the assertion that the accounts receivable which BMC established pursuant to the 99-32 closing agreement constituted related-party indebtedness between BMC and its subsidiary during the relevant § 965 testing period. The Tax Court agreed with the IRS's assertion of a deficiency.
7. BMC made two arguments in support of its appeal. First, BMC contended that as a question of statutory interpretation, the accounts receivable established by the 99-32 closing agreement did not constitute "indebtedness" within the meaning of § 965(b)(3). Second, BMC argued that it did not contractually agree, in the 99-32 closing agreement, that the accounts receivable would be treated as indebtedness for purposes of § 965(b)(3).
8. The IRS conceded at oral argument that the Service cannot prevail on the language of the statute alone. This is because it was undisputed that as of

the close of BMC's 2006 taxable year, with which ended BMC's § 965(b)(3) testing period, the accounts receivable did not exist. Nor could the accounts receivable have existed at that time: they were not created until after the parties executed the 99-32 closing agreement in 2007.

9. The Service argued that under the closing agreement, BMC agreed to backdate the accounts receivable. The Court stated the fact that accounts receivable are backdated does nothing to alter the reality that they did not exist during the testing period. The Court also stated that even assuming *arguendo* that a correction of a prior year's accounts could create indebtedness for purposes of § 965(b)(3), that is not what happened here. This is not a situation in which a subsequent adjustment was made in order to accurately reflect what actually happened in the taxable year ending on March 31, 2006.
10. BMC agreed to create previously non-existing accounts receivable with fictional establishment dates for purpose of calculating accrued interest in correcting the imbalance in its cash accounts that resulted from the primary adjustment. The text of § 965(b)(3) requires that, to reduce the allowable § 965 benefits, there must have been an indebtedness "as of the close of" the applicable taxable year. The accounts receivable were not created until 2007, and therefore BMC's § 965 benefits cannot be reduced under § 965(b)(3).
11. The Service also argued that Notice 2005-64, § 10.06, issued in 2005, supports its position. The notice states that accounts such as those created under the closing agreement "are to be treated as indebtedness for purposes of § 965(b)(3)." The Court stated there is no basis for relying on the notice to alter its interpretation of § 965(b)(3).
12. The Service correctly conceded in its brief that the notice is not entitled to deference under *Chevron USA Inc. v. Natural Res. Def. Council, Inc.*, 467 U.S. 837 (1984). At most, the notice might be entitled to deference under *Skidmore v. Swift & Co.*, 323 U.S. 134 (1944). Under *Skidmore*, courts defer to the agency only to the extent that the agency's interpretation is persuasive.
13. The Court held the notice was unpersuasive for several reasons. The notice contained only a single sentence regarding the treatment of accounts receivable as indebtedness. Moreover, the treatment of accounts receivable in the notice is entirely conclusory. The notice contains no analysis or explanation. This is particularly problematic, stated the court, in light of the fact that the notice advocates a treatment of accounts receivable that runs counter to the plain language of § 965.

14. The Court also noted that the Service has since changed its treatment of the § 965 tax consequences in closing agreements, explicitly outlining the § 965 tax consequences in these agreements.
15. With no reasoning or analysis to support its directive, and with the Service's subsequent decision to explicitly provide for the § 965 tax consequences in closing agreements, the Court held that the notice is entirely unpersuasive and unworthy of deference.
16. The Court next considered the parties' arguments over a possible alternative basis for affirming the Tax Court's holding: whether BMC nevertheless contractually agreed in the 99-32 closing agreement to treat the accounts receivable as indebtedness for purposes of § 965. In essence, stated the Court, this presents an issue of contractual interpretation.
17. The 99-32 closing agreement neither cites nor refers to § 965. The Service primarily relies upon the introductory clause, which states that "now it is hereby determined and agreed for federal income tax purposes ..." The Court stated this is a boilerplate provision required by the IRS in every closing agreement. Nonetheless, the Service argued that this demonstrates that the accounts receivable created related-party indebtedness for all income tax purposes, including § 965.
18. The Court rejected the Service's expansive interpretation of the boilerplate provision because it would render much of the agreement superfluous, and also because the agreement's enumeration of tax consequences was inclusive. The 99-32 closing agreement lists the transaction's tax implications in considerable detail. One of the paragraphs, for example, explains the tax implications flowing from the interest payments on the accounts receivable. If the parties agreed, in the boilerplate provision, to treat the accounts receivable as retroactive indebtedness for all federal income tax purposes, then these additional provisions would be surplusage. Moreover, where the specificity and apparent comprehensiveness of an agreement's enumeration of a category of things (here, tax implications) implies that things not enumerated are excluded, the Court will apply the canon of *expressio unius est exclusio alterius* (that which is not included is excluded).
19. The Court stated that the agreement lists, with specificity, several tax implications. The tax-consequence-setting function of the agreement, coupled with the specificity of its enumeration of tax consequences, strongly implies that the agreement excluded those tax consequences which it failed to enumerate.
20. Applying the rule against surplusage and the *expressio unius* canon, the Court concluded that the plain language of the 99-32 closing agreement thus precluded the IRS's expansive interpretation of the agreement's

boilerplate provision, and the agreement covers only those tax consequences that it expressly enumerates.

21. Moreover, the Court stated, even if the agreement were ambiguous as to whether the accounts receivable were retroactively established for all tax purposes, the unrebutted extrinsic evidence (testimony at trial) would require the court to resolve the ambiguity in BMC's favor.
22. The Fifth Circuit's holding would seem to eliminate a number of unnecessary collateral issues to which the Tax Court's holding would have given rise. First, under the Tax Court's holding that a Rev. Proc. 99-32 closing agreement gives rise to retroactive indebtedness, currency gain or loss presumably would arise at the foreign-subsiary level with respect to every such retroactive indebtedness. That is, it would be a retroactive dollar receivable held by the U.S. parent company and presumably a retroactive dollar payable owed by the non-dollar foreign subsidiary. Subpart F issues would arise under § 954(c).
23. Second, in certain cases, retroactive § 956 inclusions could have resulted.
24. Third, if the receivable in the hands of the parent company were treated as a retroactive receivable, then the possibility of writing off that receivable as a bad debt under § 166 could have arisen. In at least one previous case, a taxpayer indeed made this assertion, but unsuccessfully. The Tax Court's holding in *BMC* would have given new life to the bad debt argument.
25. Finally, the retroactive receivable, as found by the Tax Court, would have created a retroactive foreign asset for purposes of allocating and apportioning interest expense under Treas. Reg. § 1.861-8 in any number of prior years.
26. Unexpected collateral consequences like these would seem not to arise under the Fifth Circuit's reversal of the Tax Court.

D. Other Pending Cases.

1. *Amazon.com, Inc. v. Commissioner*, T.C. Dkt. 31197-12, involves a cost sharing agreement with allocated amounts of over \$1 billion for each of the two years in issue. It seems to involve some of the same issues that were litigated in *Veritas v. Commissioner*, 133 T.C. 297 (2009), *nonacq.*, which is cited in Amazon's Tax Court Petition.
2. *Medtronic v. Commissioner*, T.C. Dkt. 6944-11, involving §§ 482 and 367(d), was tried in Spring 2015.
3. *3M Company v. Commissioner*, T.C. Dkt. No. 5816-13, filed March 11, 2013, involves the IRS's allocation of royalty income from a Brazilian

subsidiary. The taxpayer asserts that the royalties in issue are not permitted under Brazilian law. *First Security Bank of Utah v. Commissioner*, 405 U.S. 394 (1972) held that if the law prevents the taxpayer from earning certain income, the taxpayer did not have the necessary control that § 482 requires, and an allocation under § 482 would be inappropriate. Subsequently, *Proctor & Gamble v. Commissioner*, 961 F.2d 1255 (6<sup>th</sup> Cir. 1992), held that this applies where foreign law is involved, as well. *Exxon Corp. v. Commissioner*, 66 TCM 1707 (1993), *aff'd*, *Texaco v. Commissioner*, 98 F.3d 825 (5<sup>th</sup> Cir. 1996), followed these cases with respect to Saudi Arabian crude pricing. Treasury and the IRS have tried to reverse these decisions with a regulation issued in 1994: Treas. Reg. § 1.482-1(h). I have long wondered how Treasury and the IRS could write a regulation *under* § 482 to overrule the Supreme Court's holding that § 482 *does not apply in the first case*.

E. IRS Outsources Microsoft § 482 Audit to Law Firm.

1. In a quite surprising development, the IRS has retained the law firm of Quinn Emanuel to assist in a transfer pricing audit of Microsoft. The IRS's outsourcing effort became public when Microsoft brought an action for declaratory and injunctive relief under the Freedom of Information Act ("FOIA"). Microsoft seeks to compel the disclosure of the complete government contract and related records arising from the IRS's engagement of Quinn Emanuel. Under the agreement, Quinn Emanuel will receive \$2,185,500 for its provision of these legal services.
2. Quinn Emanuel is described in Microsoft's complaint as a "650-lawyer business litigation firm—the largest in the United States devoted solely to business litigation and arbitration." Quinn Emanuel appears not to have a tax practice.
3. Previously, Microsoft had filed a FOIA request seeking all documents representing proposals for services to be rendered by Quinn Emanuel, its partners, and/or its employees in connection with the IRS's examination of Microsoft for its tax years ended June 30, 2004 through June 30, 2009. Microsoft's request included the complete contract between Quinn Emanuel and the IRS. The IRS did not produce the requested materials.
4. As discussed in an excellent article by Ajay Gupta at 2014 TNT 230-4, the disclosed portions of the contract make it clear that Quinn Emanuel will be closely associated with the IRS examination team. They state "Contractor will work collaboratively with the Service to support the examination." The law firm is tasked in the agreement with reviewing all the "key documents, including reports, position papers, IDR responses, etc. (prepared by or on behalf of the Taxpayer or the Service) and all relevant legal authorities to build a thorough understanding of the factual and legal issues and the record to date."

5. According to Gupta, the issue under scrutiny appears to involve a pre-2009 cost-sharing agreement and the sufficiency of buy-in payments. As Gupta notes, similar disputes involving cost-sharing buy-in payments were/are in issue in *Veritas* and the pending case involving Amazon.com.
6. Gupta states that under the agreement, the contractor's attorneys may "as necessary for the performance of his or her duties under this contract, be given access to confidential tax returns and return information..." Quinn Emanuel, Gupta notes, thus must be, under § 6031(n), a person to which the IRS is authorized to disclose returns and return information "for purposes of tax administration...in connection with a written contract or agreement" for services.
7. This is a very interesting and unfortunate development in the tax law: the IRS appears to have retained an outside law firm to sue a taxpayer, or assist in bringing an action against a taxpayer, asserting that the taxpayer might owe additional U.S. federal income taxes. The law firm apparently also will assist in determining whether taxes are owed and then presumably assert the grounds for arguing that those taxes, determined in part by the law firm, should be paid to the IRS. Somehow, this doesn't seem right.
8. Senator Hatch (R-UT), Senate Finance Committee Chairman, learned about this new approach and wrote to the IRS demanding that it immediately stop using Quinn Emanuel, the law firm or one of the law firms involved, and that the IRS provide "without delay" answers regarding its use of private contractors in its audits. He wants the IRS to provide the legal justification for its "novel" reading of the tax statute in hiring an outside law firm.
9. Hatch questioned the IRS's decision and criticized the fact that the IRS gave Quinn Emanuel the authority to conduct sworn interviews and perform other actions that would give the law firm access to confidential taxpayer information.
10. He said that Congress intentionally chose to restrict the performance of specific revenue functions, such as examinations and the taking of sworn testimony, to the IRS and "limited delegates."
11. In Microsoft's legal proceedings regarding this specific issue, the IRS says Hatch's letter is irrelevant to the issue.
12. In an interesting opening statement in the Microsoft evidentiary hearing dealing with the legitimacy of the IRS's use of an outside law firm, Quinn Emanuel, a Microsoft attorney raised concerns about taxpayer confidentiality. Quinn Emanuel is primary outside counsel to Google, one of Microsoft's largest competitors. Microsoft's attorney stated that at one

point after having been hired by the IRS, Quinn Emanuel was involved in 34 cases adverse to Microsoft. This fact was made known to the IRS at the time that the IRS was disclosing confidential information about Microsoft to the law firm. This is discussed along with other points from the hearing in a report by Amanda Athanasiou at 2015 TNT 165-1.

13. Two government persons stated that Quinn Emanuel was hired because the IRS believed advice from a commercial litigator with experience in evaluating large complex cases would help to determine the correct adjustment and support its numbers. The IRS had also reached out to Boies Schiller for expert services, but the firm ultimately wasn't used because of a conflict of interest.

F. Eaton.

1. Eaton Corporation has a pending § 482 case. While the case has not yet been tried, an order in the case is sufficiently surprising that I thought I would mention it. The order, dated May 11, 2015, affirmed a prior order dated April 6, 2015. The order involves the production of documents.
2. The IRS asserts that Eaton should be charged a transfer pricing accuracy-related penalty under § 6662(h). Eaton says that the penalty should not apply because it has reasonable cause for any portion of an understatement attributable to a net § 482 transfer pricing adjustment.
3. The Court's order states that although the reasonable cause defense is an objective one, it ultimately involves all the facts and circumstances, including several factors that are particular to the taxpayer asserting the defense. The taxpayer must reasonably have concluded that a particular transfer pricing method provided a reliable measure of an arm's length result. Further, the taxpayer's experience and knowledge and the extent to which the taxpayer relied on a study or other analysis performed by a qualified attorney, accountant, or economist are relevant.
4. The order states that in asserting a reasonable cause defense, Eaton has put at issue otherwise protected information that would reveal the expertise and knowledge and state of mind of those who acted on its behalf in this matter. The court cited *Ad Inv. 2000 Fund LLC v. Commissioner*, 142 T.C. 248 (2014). Thus, documents that the IRS seeks, states the order, are directly relevant to Eaton's penalty defense.
5. The issue involves attorney-client privilege with respect to the documents at issue. The court concluded that Eaton waived privilege and work product protections to withhold the documents in dispute from discovery as a consequence of asserting that the penalty should not apply. The order further states that if Eaton does not produce the documents, the court will grant so much of the IRS's motion to compel production of documents as



seeks an appropriate sanction by striking relevant portions of the petition and barring the introduction of evidence related thereto.

6. This is surprising, to say the least: attorney-client privilege is waived simply because the taxpayer asserts that a penalty should not apply. This cannot be right. In enacting penalties, did Congress really intend that privilege must be waived as the price of asserting that a penalty should not apply?
7. Imagine a typical non-tax civil or criminal case. If the defendant asserts a defense that relates to his state of mind or reasonable cause, would he be viewed as waiving privilege? I don't think so. The attorney-client privilege is a common law privilege that's pretty deeply ingrained in our legal system. It shouldn't vary by the court involved.

G. New APA Procedures.

1. Rev. Proc. 2015-41 provides guidance on requesting and obtaining advance pricing agreements and on the administration of executed APAs. A proposed version of this revenue procedure was released for public comment in Notice 2013-79, and was the subject of substantial commentary.
2. The principal differences between the final revenue procedure and the proposed version may be summarized as follows:
  - (a) The revenue procedure clarifies that if APMA (Advance Pricing and Mutual Agreement personnel) requires, as a condition of continuing with the APA process, that the taxpayer expand the proposed scope of its APA request to cover interrelated matters (interrelated issues in the same years, covered issues or interrelated issues in the same or other years and the same as applied to other countries), APMA will do so with due regard to considerations of principled, effective, and efficient tax administration and only after considering the views of the taxpayer and the applicable foreign competent authority. Further, APMA will communicate to the taxpayer any concerns about interrelated matters and possible scope expansion as early as possible.

This seems like a bit of “hardball” that could make the APMA a not-so-friendly program. After all, the APMA apparently will discuss these interrelated issues with the applicable foreign competent authority even if the taxpayer doesn't want it to. The only alternative for the taxpayer is to withdraw its APA request, but by then the damage may have been done.

Examples of interrelated matters include a taxpayer that proposes to cover a country's license of intangible property in specific years

to a second company in the same controlled group, when that intangible property had been sold in an earlier year by the second company (the licensee) to the first company (the licensor). In such a case, APMA might consider that the ongoing license should be evaluated in a manner consistent with the evaluation performed for the previous sale (for example, using the same underlying assumptions unless there were specific reasons why certain assumptions would have changed in the interim).

Another example involves cost sharing. In evaluating a platform contribution transaction in a cost sharing arrangement, APMA might also consider whether the intangible development cost in that arrangement are being properly shared.

A third example assumes that the taxpayer makes a bilateral APA request to cover sales of goods from a manufacturer in a treaty country to a U.S. distributor that is in the same controlled group, when the U.S. distributor, in turn, resells most of the goods to a distributor in another country (which may or may not be a treaty country) that is in the same controlled group. Before agreeing to a price that the U.S. distributor should pay to the manufacturer, APMA might consider the price the distributor receives for its resale.

- (b) Rollback years may be formally covered within an APA. A rollback will be included in an APA when a rollback is either requested by the taxpayer and approved after coordination and collaboration between APMA and other offices within the IRS or, in some cases, is required by APMA, after coordination and collaboration with other offices within the IRS, as a condition of beginning or continuing the APA process.
- (c) The required contents of APA requests that were specified in the appendix of the proposed revenue procedure have been refined but generally retained, which APMA uses to view as necessary to conduct informed and efficient evaluations of APA requests.
- (d) Taxpayers are required to execute consent agreements to extend the period of limitations for assessment of tax for each year of the proposed APA term, and the required consent could be either general or restricted. The revenue procedure expands on the proposed revenue procedure by expressly providing that APMA will coordinate and collaborate with other offices within the IRS and with the taxpayer on the type of consent the taxpayer will be instructed to execute, which, if restricted, will follow standardized language provided by APMA. The revenue procedure also provides that in certain cases, only general consents will be used.

- (e) The revenue procedure increases user fees for APA requests and provides that total user fees may be reduced for multiple APA requests filed by the same controlled group within a 60-day period.

3. Highlights of Other Selected Provisions.

- (a) The APA guidelines express a preference for bilateral and multilateral APAs. If a taxpayer requests a unilateral APA to cover any issue that could be covered under a bilateral or multilateral APA under the applicable tax treaties, the taxpayer must explain in a mandatory pre-filing memorandum why a unilateral APA is appropriate to cover that issue. The taxpayer might state, for example, that it believes there is no APA process with the treaty country, or that the taxpayer's proposed covered issues involve so many treaty countries that the taxpayer believes that bilateral APAs or a multilateral APA would be impractical. APMA will inform the taxpayer whether it will accept the unilateral APA request in such a situation.
- (b) Mandatory pre-filing memoranda in Section 3.02(4) must be filed if (1) the taxpayer wishes to file a unilateral APA request to cover an issue that could be covered in a bilateral or multilateral APA (as discussed above); (2) the taxpayer seeks permission to use an abbreviated APA request, for example, for an APA renewal or expansion of a competent authority request under Rev. Proc. 2015-40 into APA years; or (3) the covered issues proposed by the taxpayer will, or could reasonably be expected to, involve (i) the license or other transfer of a intangibles in connection with, or the development of intangibles under, an intangible development agreement, (ii) a global trading arrangement (iii) a business restructuring, or the use of intangibles whose ownership changed as a result of the business restructuring, or (iv) unincorporated branches, pass-through entities, hybrid entities or entities disregarded for U.S. tax purposes.
- (c) Section 4.02 sets forth rules regarding denial or discontinuance of the APA process. APMA may decline to enter into or continue with the APA process if, for example, any of the circumstances described in, or similar to those described in Rev. Proc. 2015-40 § 7.02 are present, including failure to include the materials required by Rev. Proc. 2015-41 in the request. Rev. Proc. 2015-40 § 7.02 says these circumstances may include but are not limited to: (1) the taxpayer has failed to comply with the procedural requirements in the revenue procedure; (2) the taxpayer is not eligible for the treaty benefit or the assistance requested according to a plain reading of the U.S. tax treaty; (3) if the taxpayer's conduct before or after its competent authority request has

undermined or been prejudicial to the competent authority process, including but not limited to conduct that has significantly impeded the ability of IRS Exam, the U.S. competent authority or any other part of the IRS, or the foreign tax authority to adequately examine the competent authority issues for which the assistance has been requested.

- (d) Examples of detrimental conduct include: (1) the taxpayer agreed to or acquiesced in a foreign-initiated adjustment or entered into a unilateral APA with a foreign tax authority involving significant legal or factual issues in a manner that impeded the U.S. competent authority from engaging in full and fair consultations with the foreign competent authority on the competent authority issues; (2) the taxpayer entered into a unilateral APA with the IRS when the competent authority issue could reasonably and practically have been covered if the taxpayer had instead pursued a bilateral APA; (3) the taxpayer rejected a request to extend the period of limitations for assessment of tax for taxable periods covered by the competent authority request, (4) the taxpayer has failed to comply with the provisions coordinating the competent authority process and administrative and judicial proceedings or has pursued its rights within such proceedings and within the competent authority process in a way that has undermined or is prejudicial to the competent authority process; (5) the taxpayer has presented new material information or evidence during the competent authority process that reasonably could have been presented to IRS Exam during the examination of the taxable years covered by the competent authority request; and (6) in competent authority requests or competent authority cases involving taxpayer-initiated positions, the taxpayer failed to request the assistance of the foreign competent authority and the U.S. competent authority in a timely manner in relation to the taxable year for which relief is sought, or the taxpayer otherwise pursued competent authority assistance in a way that has undermined or prejudiced the competent authority process or has impeded the U.S. or foreign competent authority from engaging in full and fair consultations on the competent authority issues.
- (e) Rev. Proc. 99-32 will govern the repatriation of funds to conform the taxpayer's accounts following an APA adjustment, unless the Competent Authority Repatriation provision applies to the APA primary adjustment. For bilateral and multilateral APAs, APMA will apply the rules of Rev. Proc. 2015-40 governing Competent Authority Repatriation to determine the terms of any repatriation of funds to conform the accounts following an APA primary adjustment if the Competent Authority Repatriation is agreed to a part of the competent authority resolution underlying the APA.

The previous APA revenue procedure, Rev. Proc. 2006-9, stated that such a repatriation would be consistent with the *principles* of Rev. Proc. 99-32. It is not clear if the Service intends a substantive change in the repatriation rules in the context of an APA or competent authority proceeding by reason of using this different language.

- (f) Section 7.06 sets forth rules on when APMA may revoke or cancel an APA.
- (g) Section 8 deals with renewing an APA. A request to renew a current APA may be made either by filing a complete APA request or by filing an abbreviated APA request with APMA's permission.
- (h) User fees were increased to \$60,000 from \$50,000 for an APA. An APA renewal requires a fee of \$35,000, and a small-case APA will cost \$30,000. In addition, a fee of \$12,500 will be due for each amendment to a current unilateral, bilateral or multilateral APA. If multiple APA requests are filed by the same controlled group within a 60-day period, the maximum total fee charged will be \$60,000, plus \$30,000 for each foreign competent authority involved (if any) beyond the first two.
- (i) Treasury and the IRS received a number of comments on the proposed APA guidelines published in Notice 2013-79. TEI, for example, stated that the proposed new APA procedure took an audit-like approach that would significantly undermine the benefits of an APA for both taxpayers and the government. TEI stated that the APA program has historically been a collaborative process between taxpayers and the IRS, aimed at promoting trust and providing certainty for both parties. TEI expressed the view that the proposed procedures and additional information required would only lengthen the time it takes to complete an APA request, significantly decreasing the utility of an APA.
- (j) The final APA procedures set forth in Rev. Proc. 2015-41 would seem to have addressed some of these criticisms, but not all. Time will tell, however, how these revised procedures work in practice.

H. Section 482. Treasury and the IRS issued temporary and proposed regulations under § 482 at the same time they proposed the § 367 regulations discussed below. They state the new regulation is to coordinate the application of the arm's length standard and the best method rule under § 482 with other Code provisions. The coordination rules apply to controlled transactions, including those subject in whole or in part to both §§ 367 and 482.

1. Consistent Valuation of Controlled Transactions.

- (a) Section 482 authorizes Treasury and the IRS to adjust the results of controlled transactions to clearly reflect the income of commonly controlled taxpayers in accordance with the arm's-length standard and, in the case of transfers of intangible property (within the meaning of § 936(h)(3)(B)), so as to be commensurate with the income attributable to the intangible.
- (b) While the determinations of arm's-length prices for controlled transactions is governed by § 482, the tax treatment of controlled transactions is also governed by other Code and regulatory rules applicable to both controlled and uncontrolled transactions. Controlled transactions always remain subject to § 482 in addition to these generally applicable provisions.
- (c) The new temporary regulations provide for the coordination of § 482 with those other Code and regulatory provisions. The new coordination rules thus apply to controlled transactions including controlled transactions that are subject in whole or in part to §§ 367 and 482. Transfers of property subject to § 367 that occur between controlled taxpayers require a consistent and coordinated application of both sections to the controlled transfer of property. The controlled transactions may include transfers of property subject to § 367(a) or (e), transfers of intangible property subject to § 367(d) or (e), and the provision of services that contribute significantly to maintaining, exploiting or further developing the transferred properties.
- (d) Treasury and the IRS say the consistent analysis and valuation of transactions subject to multiple Code and regulatory provisions is required under the best method rule described in Treas. Reg. § 1.482-1(c). A best method analysis under § 482 begins with a consideration of the facts and circumstances related to the functions performed, the resources employed, and the risks assumed in the actual transaction or transactions among the controlled taxpayers, as well as in any uncontrolled transactions used as comparables.
- (e) For example, states the preamble, if consideration of the facts and circumstances reveals synergies among interrelated transactions, an aggregate evaluation under § 482 may provide a more reliable measure of an arm's length result than a separate valuation of the transactions. In contrast, an inconsistent or uncoordinated application of § 482 to interrelated controlled transactions that are subject to tax under different Code and regulatory provisions may lead to inappropriate conclusions.

- (f) The best method rule requires the determination of the arm's-length result on controlled transactions under the method, and particular application of that method, that provides the most reliable measure of an arm's-length result. The preamble also refers to the "realistic alternative transactions" rule and states that "on a risk-adjusted basis" this may provide the basis for application of unspecified methods to determining the most reliable measure of an arm's length result.
- (g) Based on taxpayer positions that the IRS has encountered in examinations and controversy, Treasury and the IRS are concerned that certain results reported by taxpayers reflect an asserted form or character of the parties' arrangement that involves an incomplete assessment of relevant functions, resources, and risks and an inappropriately narrow analysis of the scope of the transfer pricing rules. In particular, Treasury and the IRS are concerned about situations in which controlled groups evaluate economically integrated transactions involving economically integrated contributions, synergies, and interrelated value on a separate basis in a manner that results in a misapplication of the best method rule and fails to reflect an arm's length result.
- (h) Taxpayers may assert that, for purposes of § 482, separately evaluating interrelated transactions is appropriate simply because different statutes or regulations apply to the transactions (for example, with § 367 and the regulations thereunder applying to one transaction and the general recognition rules of the Code applying to another related transaction). Treasury and the IRS believe these positions are often combined with inappropriately narrow interpretations of Treas. Reg. § 1.482-4(b)(6), which provides guidance on when an item is considered similar to the other items identified as constituting intangibles for purposes of § 482. The interpretations purport to have the effect, contrary to the arm's length standard, of requiring no compensation for some value provided in controlled transactions despite the fact that compensation would be paid if the same value were provided in uncontrolled transactions.

2. Compensation Independent of the Form or Character of Controlled Transaction.

- (a) New Temp. Treas. Reg. § 1.482-1T(f)(2)(i)(A) provides that arm's-length compensation must be consistent with, and must account for all of, the value provided between parties in a controlled transaction, without regard to the form or character of the transaction. For this purpose, it is necessary to consider the entire arrangement between the parties, as determined by the

contractual terms, whether written or imputed in accordance with the economic substance of the arrangement, in light of the actual conduct of the parties.

- (b) Is this not the very BEPS proposal the U.S. fought (is fighting) against? I'm not sure I can reconcile the two U.S. positions here and in BEPS.
- (c) The preamble says this requirement is consistent with the principles underlying the arm's length standard, which require that arm's length compensation in controlled transactions equal the compensation that would have occurred if a similar transaction had occurred between similarly situated uncontrolled taxpayers.
- (d) This is the very position of the pro-BEPS countries in regard to this provision. There, the U.S. disagrees. Here, Treasury and the IRS like the argument.

3. Aggregate or Separate Analysis.

- (a) Temp. Treas. Reg. § 1.482-1T(f)(2)(i)(B) changes (the preamble asserts this is a "clarification") Treas. Reg. § 1.482-1(f)(2)(i)(A), which provided that the combined effect of two or more separate transactions (whether before, during, or after the year under review) may be considered if the transactions, taken as a whole, are so interrelated that an aggregate analysis of these transactions provides the most reliable measure of an arm's-length result determined under the best method rule of Treas. Reg. § 1.482-1(c).
- (b) Specifically, a new clause was added to provide that this aggregation principle also applies for purposes of an analysis under multiple provisions of the Code or regulations. A new sentence also elaborates on the aggregation principle by noting that consideration of the combined effect of two or more transactions may be appropriate to determine whether the overall compensation is consistent with the value provided, including any synergies among items and services provided.
- (c) The temporary regulation does not retain the statement in Treas. Reg. § 1.482-1(f)(2)(i)(A) that transactions generally will be aggregated only when they involve "related products or services."
- (d) Curiously, the Obama Administration proposed a change in the statute to permit this type of aggregation (a "clarification" of the law said the explanation), but that proposal was never enacted. This would seem to raise some questions about Treasury and the IRS's changing the law by regulations when Congress has declined to act.



4. Aggregation and Allocation for Purposes of Coordinated Analysis.

- (a) Temp. Treas. Reg. § 1.482-1T(f)(2)(i)(C) provides that, for one or more controlled transactions governed by one or more provision of the Code and regulations, a coordinated best method analysis and evaluation of the transactions may be necessary to ensure that the overall value provided (including any synergies) is properly taken into account. A coordinated best method analysis of the transactions includes a consistent consideration of the facts and circumstances of the functions performed, resources employed, and risks assumed, and a consistent measure of the arm's length results, for purposes of all relevant Code and regulatory provisions.
- (b) For example, situations in which a coordinated best method analysis and evaluation may be necessary include: (1) two or more interrelated transactions when either all of the transactions are governed by one regulation under § 482 or all are governed by one subsection of § 367, (2) two or more interrelated transactions governed by two or more regulations under § 482, (3) a transfer of property subject to § 367(a) and an interrelated transfer of property subject to § 367(d), (4) two or more interrelated transactions when § 367(d) applies to one transaction and the general recognition rules of the Code apply to another interrelated transaction, and (5) other circumstances in which controlled transactions require analysis under multiple Code and regulatory provisions.
- (c) Temp. Treas. Reg. § 1.482-1T(f)(2)(i)(D) provides that it may be necessary to allocate the arm's length result that was properly determined under a coordinated best method analysis described in Temp. Treas. Reg. § 1.482-1T(f)(2)(i)(C) among the interrelated transactions. An allocation must be made using the method that, under the facts and circumstances, provides the most reliable measure of an arm's length result for each allocated amount.

5. Examples of Coordinated Best Method Analysis.

- (a) Temp. Treas. Reg. § 1.482-1T(f)(2)(i)(E) provides 11 examples to illustrate the new guidance. Examples 1 through 4 are materially the same as the examples in Treas. Reg. § 1.482-1(f)(2)(i)(B). Treasury and the IRS do not intend for the revisions to those examples to be interpreted as substantive. The rest of the examples are new.
- (b) Example 1 is titled "Aggregation of Interrelated Licensing, Manufacturing and Selling Activities." Example 2 describes an aggregation of interrelated manufacturing, marketing and services activities. Example 3 is titled "Aggregation and Reliability of

Comparable Uncontrolled Transactions,” and Example 4 is described as covering non-aggregation of transactions that are not interrelated.

- (c) The first new example, Example 5, is titled “Aggregation of Interrelated Patents.” In the example, P owns 10 individual patents that in combination, can be used to manufacture and sell a successful product. P anticipates that it can earn \$25 from the patents based on a discounted cash flow analysis that provides a more reliable measure of the value of the patents exploited as a bundle rather than separately.
- (d) P licenses all 10 patents to S-1 to be exploited as a bundle. Evidence of uncontrolled licenses of similar individual patents indicates that, exploited separately, each license of each patent would warrant a price of \$1, implying a total value for the patents of \$10. The example states that it would not be appropriate to use the uncontrolled licenses as comparables for the license of the bundle of patents, because, unlike the discounted cash flow analysis, the uncontrolled licenses considered separately do not reasonable reflect the enhancement to value resulting from the interrelatedness of the 10 patents exploited as a bundle.
- (e) Example 6, “Consideration of Entire Arrangement, Including Imputed Contractual Terms,” states that P contributes the foreign rights to conduct a business, including foreign rights to certain IP, to newly incorporated S-1. P treats the transaction as a transfer described in §§ 351 and 367. Subsequently, P and S-1 enter into a cost sharing arrangement. P takes the position that the only platform contribution transactions (“PCTs”) in connection with the second transaction (the cost sharing agreement) consist of P’s contribution of the U.S. business IP rights and S-1’s contribution of the rest-of-the-world rights of which S-1 had become the owner due to the prior transaction.
- (f) The example states that the IRS may consider the economic substance of the entire arrangement between P and S-1, including the parties’ actual conduct throughout their relationship, regardless of the form or character of the contractual arrangement that the parties have expressly adopted. In the example, the IRS determines that the parties’ formal arrangement fails to reflect the full scope of the value provided between the parties in accordance with the economic substance of their arrangement. Therefore, the IRS may impute one or more agreements between P and S, consistent with the economic substance of their arrangement.

- (g) Example 7 is titled “Distinguishing Provision of Value from Characterization.” P developed a collection of resources, capabilities and rights (“Collection”) that it uses on an interrelated basis in ongoing R&D. Under § 351, P transfers certain IP to S-1 related to the Collection. P claims a portion of the property (Portion 1) is subject to § 367(d), and that another portion (Portion 2) is not taxable under § 367. The new temporary regulations are applied to determine the value to P. Whether Portion 2 is characterized as “property” under § 367 is irrelevant because any value in Portion 2 must be compensated by S-1 in a manner that is consistent with the new rules.
- (h) Examples 8 and 9 also involve multiple transactions regarding § 351 and a cost sharing agreement.
- (i) Example 10, “Services Provided Using Intangibles,” states that P’s worldwide group produces and markets product X and subsequent generations of products that result from research and development activity performed by P’s R&D team. Through this collaboration with respect to P’s proprietary products, the members of the R&D team have individually and as a group acquired specialized knowledge and expertise subject to non-disclosure agreements.
- (j) P arranges for the R&D team to provide research and development services to create a new line of products, building on the product X platform to be owned and exploited by S-1 in the overseas market. P asserts that the arm’s-length charge for the services is only a reimbursement to P of its associated R&D team compensation costs.
- (k) Even though P did not transfer the platform or the R&D team to S-1, P is providing value associated with the use of the platform, along with the value associated with the use of the know-how, to S-1 by way of the services performed by the R&D team for S-1 using the platform and the know-how.
- (l) The example states that the R&D team’s use of the intangible property, and any other valuable resources, in P’s provision of services must be evaluated under the § 482 regulations, including the regulations specifically applicable to the controlled services transactions in Treas. Reg. § 1.482-9.
- (m) Example 11 deals with “Allocating Arm’s-Length Compensation Determined Under an Aggregate Analysis.” P provides services to S-1. P licenses intellectual property to S-2 and S-2 sublicenses the intellectual property to S-1. The example states that if an aggregate analysis of the service and license transactions provides

the most reliable measure of an arm's-length result, then an aggregate analysis must be performed. If an allocation of the value that results from the aggregate analysis is necessary, for example, for purposes of sourcing the service income that P receives from S-1 or to determine the deductible expenses incurred by S-1, then the value determined under the aggregate analysis must be allocated using the method that provides the most reliable measure of the services income and the deductible expenses.

6. Effective/Applicability Dates. The regulations apply to taxable years ending on or after September 14, 2015. The preamble contains the usual caveat: No inference is intended regarding the application of the provisions amended by the temporary regulations under current law. The IRS may, when appropriate, challenge transactions, including those described in the temporary regulations, under currently applicable Code or regulatory provisions or judicial doctrines.

### III. SUBPART F.

#### A. Subpart F Branch Rule.

1. AM 2015-002, a Chief Counsel Advice ("CCA"), addresses the § 954(d)(2) branch rule regulations and how to determine the effective foreign rates of tax under the tax-rate disparity test.
2. The CCA states the issue as: "What is the most appropriate method of calculating the actual effective rate of tax and the hypothetical effective rate of tax for purposes of determining whether there is a rate disparity pursuant to the regulations under § 954(d)(2) in the case of property manufactured by a CFC?"
3. The CCA concludes: "In the case of property manufactured by a CFC, the most appropriate method of calculating the actual effective rate of tax and the hypothetical effective rate of tax is to divide the actual tax and the hypothetical tax by the hypothetical tax base determined under the laws of the manufacturing jurisdiction."
4. In year 1, CFC, a controlled foreign corporation incorporated in Country B, purchased raw materials from an unrelated supplier and used them to manufacture (under the principles of Treas. Reg. § 1.954-3(a)(4)) Product X in Country B. DE is the wholly owned subsidiary of CFC and is treated as a disregarded entity under the check-the-box regulations. DE is located in Country A and does not engage in any manufacturing activities.
5. DE derives 100x of commission income in connection with the sale of Product X by CFC to unrelated customers located outside of Country A and Country B. DE incurs 30x of sales expenses related to the sale of

Product X. CFC has no other income that would constitute foreign base company income under § 954.

6. Countries A and B both impose a 20% statutory rate of tax on sales income. Country A allows DE to exclude half of its income from the sale of products manufactured and sold for use outside of Country A. Country B does not tax DE's sales income until it is remitted to CFC as a dividend. Both Country A and Country B would allow a 30x deduction for the sales expenses. DE paid 4x of income tax in Country A in year 1.
7. What's a branch? The CCA states that for federal income tax purposes, DE is treated as a branch or division of CFC. While perhaps not an issue in the CCA, I would note that significant additional analysis could be necessary in reaching this conclusion. Under former Treas. Reg. § 1.963-1(f)(4), for example, a branch (at least for purposes of former § 963) was defined to mean "a permanent organization maintained in a foreign country or possession...to engage in the active conduct of a trade or business." That regulation also stated that as a general rule, "a permanent organization shall be considered to be maintained in such a country or possession if the U.S. shareholder maintains there in a significant workforce or significant manufacturing, mining, warehousing, sales, office or similar business facilities of a fixed or permanent nature." The examples indicated that a significant workforce was necessary as well as significant facilities. In one of the examples, a few clerical employees did not give rise to a branch.
8. Under *Ashland Oil v Commissioner*, 95 T.C. 348 (1990), the term "branch" for branch rule purposes similarly is to be construed using its customary and normal business meaning: "a division, office or other unit of business located at a different location from [the] main office or headquarters." *Ashland* also held that the term "similar establishment" means "an establishment that bears the typical characteristics of an ordinary-usage branch, yet goes by another name for accounting, financial reporting, local law or other purposes." See also *Vetco v Commissioner*, 95 T.C. 579 (1990). *Vetco*, interestingly, also cited former Treas. Reg. § 1.963-1(f)(4)(i), discussed above.
9. Selling activities. A second, separate analysis also is necessary before engaging in a branch-rule tax-rate comparison. A branch can give rise to branch-rule issues only if the branch performs selling activities (or if the remainder does so under the manufacturing branch rule). The CCA states that DE could either purchase Product X from CFC and sell it to unrelated customers at a markup or receive commissions from CFC *ostensibly* for facilitating sales from CFC to unrelated customers, without taking title to Product X. It is not clear what "ostensibly for facilitating sales" means. Are these commissions paid for DE's performing selling activities? Do

the activities in “facilitating sales” constitute the required “selling activities”?

10. Under TAM 8509004, the following activities do not constitute selling activities: (1) “management personnel charged with the responsibility of supervising various aspects of the business,” and (2) “market research activities, such as forecasting demand of new markets and analysis of methods of financing export sales.”
11. In *Ashland Oil*, the Tax Court considered the dictionary definition of the term “branch” in determining its customary and normal business meaning. A California case similarly looked to the dictionary to determine the common usage of the terms “selling” and “selling activity.” The State Board of Equalization in *Barnes & Noble.com*, September 12, 2002, after considering the dictionary’s definition, held that selling is “inclusive of all activities that are an integral part of making sales.” This includes “offering for sale” and “solicitation.” The term “selling,” in the Board’s view, is not synonymous with the term “sale.” *See also Borders Online.com*, State Board of Equalization, September 26, 2001. The California Court of Appeals subsequently affirmed this interpretation (although *Barnes & Noble* itself was reversed by a lower court on a different issue).
12. These items would seem to put into question the CCA’s use of the term “facilitating sales.” Is this activity, which is not further described in the CCA, an “integral part” of making the sales? The answer is not apparent from the CCA.
13. Tax-rate test. In any event, we now turn to the CCA’s discussion of the tax-rate test. The CCA quotes Treas. Reg. § 1.954-3(b)(1)(i)(b):

“The use of the branch or similar establishment for such activities will be considered to have substantially the same tax effect as if it were a wholly owned subsidiary corporation of the controlled foreign corporation if [that income derived by the branch or similar establishment from the purchase or sale of personal property on behalf of a related person] is, by statute, treaty obligation, or otherwise, taxed in the year when earned at an effective rate of tax [(the “actual effective rate of tax”)] that is less than 90 percent of, and at least 5 percentage points less than, the effective rate of tax [(the “hypothetical effective rate of tax”)] which would apply to such income under the laws of the country in which the controlled foreign corporation is created or organized if, under the laws of such country, the entire income of the controlled foreign corporation were considered derived by the controlled foreign corporation from sources within such country from doing business through a permanent establishment therein, received in such country, and allocable to such

permanent establishment, and the corporation were managed and controlled in such country.”

14. The quote above applies under the sales-branch rules. The tax-rate disparity test that applies under the manufacturing-branch rules compares the actual effective rate of tax in the CFC’s country of organization to the hypothetical effective rate of tax in the manufacturing branch’s location. Branch-to-branch tax-rate comparisons also can result under those rules, depending upon where the selling activities are located.
15. The tax-rate disparity test compares the effective rate of tax that applied or would apply to the income from certain sales transactions in two different countries, states the CCA. For the comparison to be meaningful, an appropriate common tax base must be used to calculate the actual effective tax rate and the hypothetical effective tax rate. Computing the actual and hypothetical effective tax rates with respect to dissimilar tax bases would be contrary to the legislative purpose of § 954(d), states the CCA. It would ignore the incentive to shift income from the manufacturing jurisdiction to a sales jurisdiction that grants exclusions and deductions to achieve a smaller tax base.
16. Thus, the most appropriate method of computing the actual effective tax rate and the hypothetical effective tax rate, states the CCA, is to use the hypothetical sales income tax base in the manufacturing jurisdiction (the “hypothetical tax base”) as a common denominator to determine the difference in the effective tax rates on the sales income shifted from the manufacturing jurisdiction.
17. The CCA calculates the tax rate disparity in five steps. First, the relevant income must be identified. The relevant income on which the tax-rate disparity test is based is the sales branch’s gross income derived in connection with the sale of property sold on behalf of the CFC. Second, the actual rate of tax (in Country A) must be determined. Third, the hypothetical tax base must be determined by calculating the amount of gross income that hypothetically would be subject to income tax in the CFC’s jurisdiction (Country B). This requires applying the income assumptions set forth in the regulation (above). The gross income determined by applying the special rules in the branch rule regulation is reduced by exclusions and deductions that would be permitted under laws of the country in which the property is manufactured (Country B). Fourth, the hypothetical tax base is multiplied by the applicable marginal tax rates in the CFC’s country of incorporation (the manufacturing jurisdiction) to yield the hypothetical tax. Finally, the hypothetical tax and actual tax paid are each divided by the hypothetical tax base to determine the effective rates of tax that will be compared for purposes of determining whether there is a tax rate disparity.

18. Based on the facts set forth in the CCA, DE derives 100x of gross income in connection with the sale of Product X. Thus, the relevant gross income is 100x. The actual tax rate paid or incurred in Country A must be determined. Under the facts set forth in the CCA, the actual tax paid or incurred in Country A is 4x. DE has 100x of gross income less an exclusion of 50x and a deduction for sales expenses of 30x. Country A taxable income is 20x. The statutory rate is 20%. Tax is 4x.
19. Next, the hypothetical tax base must be determined. The hypothetical tax base is 70x, calculated by starting with the 100x of gross income and deducting the 30x of sales expenses that are allocable and apportionable to the gross income under Country B's laws. The hypothetical tax that would have been incurred had the income been derived in Country B is calculated as follows:  $100x - 30x \text{ sales expenses} = \text{hypothetical tax base of } 70x$ .  $70x \text{ times the statutory rate of } 20\% \text{ equals } 14x \text{ in hypothetical tax}$ .
20. The actual tax of 4x over 70x equals an actual tax rate of 5.71%. The hypothetical effective rate of tax is 14x over 70x equals 20%.
21. Thus, on these facts the branch rule will apply as the actual tax in Country A (the sales jurisdiction) is less than 90% of, and at least 5 percentage points below, the hypothetical effective tax rate in Country B (the manufacturing jurisdiction).
22. Previous regulation erroneously was deleted. Hypothetical tax rate issues used to be covered in the Subpart F regulations. They were covered in previous Treas. Reg. § 1.954-3(b)(2)(i)(d). That regulation said that "In determining the hypothetical effective rate of tax, the principles of Treas. Reg. § 1.954-1(b)(4)(ii) shall be used to determine the hypothetical tax rate." The cross-referenced regulation subsequently was renumbered Treas. Reg. § 1.954-1(b)(3)(iv).
23. The cross-referenced regulation was entitled "Determination of Hypothetical Tax." It stated, among other things, that the hypothetical tax shall be computed on the basis of the actual facts concerning the corporation (except for the assumptions made with respect to source, receipt and allocation of income, type of establishment, etc.) and by deducting from such item of income all deductions allocable thereto other than income, war profits, and excess profits or similar taxes.
24. The regulation stated that if the laws of the country impose a graduated rate of income tax on the income of corporations, the tax shall be computed on the basis of the amount of the corporation's income which would be taken into account for the taxable year in determining the tax under the assumptions but otherwise using the actual facts concerning the corporation.



25. The regulation also provided that if the effective rate of tax which that country imposes differs from class-to-class of income (whether because the law of the country prescribes a different rate for each class or does so in effect by prescribing special deductions or credits with respect to that class), the tax in respect of the item of income shall be computed on the basis of the tax which under the assumptions would have been imposed for the taxable year on the class containing that item but otherwise using the actual facts concerning the corporation.
26. The regulation stated that if the rate of tax imposed by the country on a corporation with respect to income not distributed differs from the rate with respect to its distributed income, the tax in respect of the item of income shall be computed at the effective rate of tax applicable to such corporation for the taxable year, computed on the basis of the assumptions and the distributions actually made for such year by the corporation.
27. In adopting the modified branch rule regulations in 2008, Treasury and the IRS seemingly inadvertently dropped that cross-reference. Today, Treas. Reg. § 1.954-3(b)(2)(i)(d) is marked “reserved.” I never understood the reason for deleting the cross-reference since the guidance for determining the hypothetical tax rate was very important.
28. By deleting this important cross-reference, the Service was left with a need to issue rulings addressing the matter on a case-by-case basis. For example, LTRs 200942034 and 200945036 involved issues such as the treatment of a disregarded note (holding that it should be taken into account since it’s regarded in the foreign country), a deemed deduction on net equity, and the existence of a foreign advance pricing agreement.
29. These issues all would seem to have been addressed in the previous regulation (that is, use the “actual facts”).
30. It would be helpful if the Service were to modify Treas. Reg. § 1.954-3(b)(2)(i)(d) to remove the “reserved” label and insert a rule with respect to determining hypothetical tax. The previous regulation’s reference to using the “actual facts” by itself was a helpful directive. There should not be a need to issue rulings and chief counsel advices from time to time addressing the issue on a case-by-case basis.

B. § 956 Anti-Avoidance Rule: Temporary Regulations.

1. Temp. Treas. Reg. § 1.956-1T(b)(4) contains a § 956 anti-avoidance rule. Previously, the rule provided that at the IRS’s discretion, a CFC will be considered to hold indirectly investments in U.S. property acquired by any other foreign corporation that is controlled by the CFC if one of the principal purposes for creating, organizing, or funding (through capital

contributions or debt) the other foreign corporation is to avoid the application of § 956 regarding the CFC.

2. As modified, the rule can also apply when a foreign corporation controlled by a CFC is funded other than through capital contributions or debt. The new temporary regulation provides that for purposes of § 956, U.S. property held indirectly by a CFC involves:
  - (a) United States property acquired by any other foreign corporation that is controlled by the CFC if a principal purpose of creating, organizing or funding by any means (including through capital contributions or debt) the other foreign corporation is to avoid the application of § 956 with respect to the CFC; and
  - (b) Property acquired by a partnership that is controlled by the CFC if the property would be U.S. property if held directly by the CFC, and a principal purpose of creating, organizing or funding by any means (through capital contributions or debt) the partnership is to avoid the application of § 956 with respect to the CFC.
3. The temporary regulation adds an example involving the funding of one CFC by another CFC that controls it to illustrate the application of the anti-avoidance rule when the principal purpose for funding the first CFC is to avoid the application of § 956 regarding the funding CFC, even though there would be a § 956 inclusion related to the CFC that received the funding.
4. The example illustrates that the CFCs' tax attributes associated with § 956 inclusion (such as total earnings and profits, previously taxed earnings and profits, and foreign tax pools) are taken into account in determining whether a principal purpose of funding was to avoid the application of § 956 with respect to the funding CFC. The example also clarifies that if the CFC is considered to indirectly hold U.S. property pursuant to Temp. Treas. Reg. § 1.956-1T(b)(4), then the CFC that actually holds the U.S. property will not be considered to hold the property for purposes of § 956.
5. Previously, the temporary Treasury regulation applied if “one of the principal purposes” for the transaction was to avoid the application of § 956 with respect to the CFC. As modified, the temporary regulation applies when “a principal purpose” for the transaction is to avoid the application of § 956 with respect to the CFC. Treasury and the IRS do not view this modification as a substantive change, since both formulations appropriately reflect that there may be more than one principal purpose for a transaction.

6. Treasury and the IRS also believe the regulation should apply without requiring the IRS to exercise its discretion, and, therefore, modified the rule so that it is now self-executing.
7. The preamble also says that Treasury and the IRS “understand” that taxpayers may be using partnerships to structure transactions that are similar to the types of transactions addressed by the anti-abuse rule. For example, with a principal purpose of avoiding the application of § 956, a CFC might contribute cash to a partnership in exchange for an interest in the partnership, which in turn lends the cash to a U.S. shareholder of the CFC. In such a case, the shareholder may take the position that the CFC is not treated as indirectly holding the entire obligation of the U.S. shareholder but instead is treated as holding the obligation only to the extent of the CFC’s interest in the partnership under Treas. Reg. § 1.956-2(a)(3). The new temporary regulation’s provision applicable to partnerships will apply only to the extent that the amount of U.S. property that a CFC would be treated as holding under the new rule exceeds the amount that it would be treated as holding under Treas. Reg. § 1.956-2(a)(3).
8. Treasury and the IRS also understand that CFCs are engaging in transactions in which a CFC lends funds to a foreign partnership, which then distributes the proceeds from the borrowing to a U.S. partner that is related to the CFC and whose obligation would be U.S. property if it were held (or treated as held) by the CFC. Alternatively, the CFC could guarantee a loan to the foreign partnership, which then would distribute the loan proceeds to a related U.S. partner. Treasury and the IRS are concerned that these taxpayers take the position that § 956 does not apply to these transactions even though the CFC’s earnings are effectively repatriated to a related U.S. partner.
9. In response to these transactions, the temporary regulations add § 1.956-1T(b)(5) to address cases in which a CFC funds a foreign partnership (or guarantees a borrowing by a foreign partnership) and the foreign partnership makes a distribution to a U.S. partner that is related to the CFC.
10. For purposes of § 956, new Temp. Treas. Reg. § 1.956-1T(b)(5) treats the partnership obligation as an obligation of the distributee partner to the extent of the lesser of the amount of the distribution that would not have been made but for the funding of the partnership or the amount of the foreign partnership obligation. For example, if a related U.S. shareholder of a CFC has an interest in a foreign partnership, the CFC lends \$100 to the partnership, and the CFC distributes \$100 to the U.S. shareholder in a distribution that would not have been made but for the loan from the CFC, then the entire \$100 partnership obligation held by the CFC will be treated as an obligation of the U.S. shareholder that constitutes U.S. property.

11. The rules in Temp. Treas. Reg. § 1.956-1T(b)(4) apply to taxable years of CFCs ending on or after September 1, 2015, and to taxable years of U.S. shareholders in which or with which such taxable years end, with respect to property acquired, including property treated as acquired as a result of a deemed exchange of property pursuant to § 1001, on or after September 1, 2015.
12. The rule in Temp. Treas. Reg. § 1.956-1T(b)(5) (regarding partnerships) applies to taxable years of CFCs ending on or after September 1, 2015, and to taxable years of U.S. shareholders in which or with which such taxable years end, in the case of distributions made on or after September 1, 2015.
13. The preamble states that no inference is intended as to the application of the provisions amended by these provisions under current law. The IRS may, where appropriate, challenge transactions, including those described in these temporary regulations under currently applicable Code or regulatory provisions or judicial doctrines.

C. Section 956 Proposed Regulations.

1. Obligations of Foreign Partnerships.

- (a) The IRS and Treasury sought comments regarding whether the rules under § 956 should treat an obligation of a foreign partnership held by a CFC as an obligation of a foreign person, rather than as an obligation of its partners, including any partners that are U.S. persons. The comments noted that the inclusion of a domestic partnership in the definition of U.S. in § 7701 causes an obligation of a domestic partnership to be treated as an obligation of a U.S. person for purposes of § 956. Thus, comments asserted that § 956 implicitly treats both domestic and foreign partnerships as entities, rather than as aggregates of their partners, for purposes of determining whether an obligation of a partnership is U.S. property. As a result, an obligation of a foreign partnership with one or more partners that are U.S. persons should not be treated as an obligation of a U.S. person for purposes of § 956.
- (b) The preamble to the proposed regulations states that § 956 is intended to prevent a U.S. shareholder of a CFC from inappropriately deferring U.S. taxation of CFC earnings by preventing the repatriation of income to the U.S. in a manner that does not subject it to U.S. tax. In the absence of § 956, a U.S. shareholder of a CFC could access the CFC's funds (untaxed earnings and profits) in a variety of ways other than by payment of an actual taxable dividend. Absent § 956, there would be no reason for the U.S. shareholder to incur a dividend tax. Section

956 ensures that, to the extent CFC earnings are made available for use in the U.S. or for use by a U.S. shareholder, the U.S. shareholder of the CFC is subject to current U.S. tax with respect to these amounts.

- (c) Treasury and the IRS have determined that failing to treat an obligation of a foreign partnership as an obligation of its partners would allow deferral of U.S. taxation of CFC earnings and profits in a manner inconsistent with the purposes of § 956. When a U.S. shareholder can conduct operations through a foreign partnership using deferred CFC earnings, those earnings effectively have been made available to the U.S. shareholder. Additionally, states the preamble, because assets of a partnership generally are available to the partners without additional U.S. tax, a U.S. shareholder could directly access deferred CFC earnings lent to a foreign partnership in which the U.S. shareholder is a partner without those earnings becoming subject to current U.S. tax by causing the partnership to make a distribution.
- (d) In light of these considerations, the proposed regulations treat an obligation of a foreign partnership as an obligation of its partners for purposes of § 956, subject to a minor exception for obligations of foreign partnerships in which neither the lending CFC nor any person related to the lending CFC is a partner (*see* § 956(c)(2)(L)). More specifically, Prop. Treas. Reg. § 1.956-4(c)(1) generally treats an obligation of a foreign partnership as an obligation of the partners to the extent of each partner's share of the obligation as determined in accordance with the partner's interest in partnership profits.
- (e) Treasury and the IRS considered various methods for determining a partner's share of a partnership obligation, including the regulations under § 752, the liquidation value percentage, and the partner's interest in partnership profits. They believe that using the partner's interest in partnership profits to determine a partner's share of a partnership obligation is consistent with the observation that, to the extent the proceeds of a partnership borrowing are used by the partnership to invest in profit-generating activities, partners in the partnership (including service partners with limited or no partnership capital) will benefit from the partnership obligation to the extent of their interests in the partnership profits. They also believe this will make the rule more administrable. However, Treasury and the IRS solicited comments in this regard.
- (f) The determination of a partner's share of the obligation will be made as of the close of each quarter of the CFC's taxable year in connection with the calculation of the amount of U.S. property

held by the CFC for purposes of § 956. Thus, for example, if a partner in a foreign partnership is a U.S. shareholder of a CFC, an obligation of the partnership that is held by the CFC will be treated as U.S. property to the extent of the U.S. shareholder partner's share of the obligation as determined in accordance with the partner's interest in partnership profits as of the close of each quarter of the CFC's taxable year.

- (g) The new rule also applies to determine the extent to which a CFC guarantees or otherwise supports an obligation of a related U.S. person when the related U.S. person is a partner in a foreign partnership that incurred the obligation that is the subject of the CFC's credit enhancement. Similarly, if a CFC is a partner in a foreign partnership that owns property that would be U.S. property if held by the CFC, and the property is subject to a liability that would constitute a specific charge within the meaning of Treas. Reg. § 1.956-1(e)(1), the CFC's share of the liability, as determined under proposed Treas. Reg. § 1.956-4(c)(1), would be treated as a specific charge that, under Treas. Reg. § 1.956-1(e)(1), could reduce the amount taken into account by the CFC in determining the amount of its share of U.S. property.
- (h) This newly proposed approach to partnerships and § 956 raises important legal issues. If the foreign partnership is a limited liability entity treated as a partnership for U.S. tax purposes, such as an entity to which a check-the-box election applies, assuming those entities are subject to the new rule, then the partners do not have liability for the partnership's liabilities. In such a case, there is no "obligation of a U.S. person" to which § 956 could apply. Can there even be a § 956 obligation in that case? Can Treasury and the IRS's policy concerns override the clear statutory language? This is discussed further below in the context of disregarded entities.
- (i) The newly proposed rule also doesn't consider whether the funds were distributed to the U.S. partner. What if the foreign partnership is a large operating company that borrowed the money to use in its business? Can there even be a § 956 policy concern in that case?
- (j) In a NYS Bar Association Tax Section ("NYSBA") commentary dated June 30, 2006, the NYSBA recommended that subject to an exception, a loan by a CFC to a related foreign partnership should not be treated as an investment in U.S. property for § 956 purposes (irrespective of whether the partners in the foreign partnership are U.S. or foreign persons) if the loan proceeds are not invested in U.S. property or otherwise distributed to any U.S. partners in the

partnership. A loan by a CFC to a foreign partnership, however, should be treated as an investment in U.S. property for purposes of § 956 if the loan would be treated under general U.S. federal income tax principles (such as “Plantation Patterns”) as made to a U.S. partner of the foreign partnership that is a U.S. shareholder of the CFC.

- (k) On a different point, one commentator said that if a U.S. shareholder of a CFC is a partner in a foreign partnership and is treated as having an inclusion under § 956 when the CFC makes a loan to the partnership and that partner later receives an actual distribution from the partnership, the partner could have an inappropriate second inclusion later when it is deemed to receive a distribution from the partnership upon the partnership’s repayment of the loan. The second inclusion could arise under Subchapter K to the extent the partner is required to reduce its basis in its partnership interest on the actual distribution and again reduce its basis as a result of the deemed distribution under § 752(b) when its share of the loan is repaid. If the distributions succeed the partner’s basis in the partnership, including the increase to basis under § 752(a) when the partnership originally incurred the obligation, the partner could recognize gain under § 731. The commenter suggested that having inclusions under both § 956 and Subchapter K would be inappropriate.
- (l) In considering this comment, Treasury and the IRS concluded that the proposed regulations and the existing rules under Subchapter K and § 959 provide the appropriate result in that fact pattern. The potential for gain under Subchapter K exists regardless of the application of § 956. In the view of Treasury and the IRS, the required inclusion under the proposed regulations to the extent a CFC is treated as holding an obligation of a U.S. person reflects policy considerations distinct from the policy considerations underlying the potential results under Subchapter K. Moreover, in the fact pattern, the U.S. property held by the CFC in connection with its loan to the partnership generates previously taxed earnings and profits under § 959 and, in general, those earnings and profits are available for distribution by the CFC to its U.S. shareholder without further U.S. tax on the distributed amount.

## 2. Special Rule in the Case of Certain Distributions.

- (a) The proposed regulations contain a provision that would increase the amount of a foreign partnership obligation that is treated as U.S. property under the general rule when the following requirements are satisfied: (1) a CFC lends funds (or guarantees a loan) to a foreign partnership whose obligation is, in whole or in

part, U.S. property with respect to the CFC pursuant to proposed Treas. Reg. § 1.956-4(c)(1); (2) the partnership distributes the proceeds to a partner that is related to the CFC (within the meaning of § 954(d)(3)) and whose obligation would be U.S. property if held by the CFC; (3) the foreign partnership would not have made the distribution but for a funding of the partnership through an obligation held (or treated as held) by the CFC; and (4) the distribution exceeds the partner's share of the partnership obligation as determined in accordance with the partner's interest in partnership profits.

- (b) When these requirements are satisfied, proposed Treas. Reg. § 1.956-4(c)(3) provides that the amount of the partnership obligation that is treated as an obligation of the distributee partner (and thus as U.S. property held by the CFC) is the lesser of the amount of the distribution that would not have been made but for the funding of the partnership and the amount of the partnership obligation.
- (c) For example, assume a U.S. shareholder of a CFC that is related to the CFC within the meaning of § 954(d)(3) has a 60% interest of the profits of the foreign partnership and the CFC lends \$100 to the partnership. If the partnership in turn distributes \$100 to the U.S. shareholder in a distribution that would have not been made but for the funding of the CFC, the CFC will be treated as holding U.S. property in the amount of \$100.
- (d) Temp. Treas. Reg. § 1.956-1T(b)(5), discussed in the previous section above, also addresses this funded distribution fact pattern. That temporary regulation also provides that the obligation of the foreign partnership is treated as an obligation of the distributee partner when similar conditions are satisfied. Treasury and the IRS expect to withdraw Temp. Treas. Reg. § 1.956-1T(b)(5) as unnecessary when proposed Treas. Reg. § 1.956-4(c), including proposed Treas. Reg. § 1.956-4(c)(3), is adopted as a final regulation.

### 3. Pledges and Guarantees.

- (a) Treas. Reg. § 1.956-2(c)(1) provides that, subject to an exception, any obligation of a U.S. person with respect to which a CFC is a pledgor or a guarantor is considered for purposes of § 956 to be U.S. property held by the CFC. This rule will be revised to clarify that the CFC that is a pledgor or guarantor of an obligation of a U.S. person is treated as holding the obligation. Accordingly, under the proposed rule, the general exceptions to the definition of



U.S. property would apply to the obligation treated as held by the CFC.

- (b) The proposed regulations provide that the pledge and guarantee rules under Treas. Reg. § 1.956-2(c) apply to a CFC that directly or indirectly guarantees an obligation of a foreign partnership that is treated as an obligation of a U.S. person under proposed Treas. Reg. § 1.956-4(c). Accordingly, if an obligation of a foreign partnership is treated as an obligation of a U.S. person pursuant to the proposed regulation and the CFC directly or indirectly guarantees the partnership obligation, the CFC will be treated as holding an obligation of the U.S. person.
- (c) The proposed regulations also extend the pledge and guarantee rule in Treas. Reg. § 1.956-2(c)(1) to pledges and guarantees made by partnerships. Thus, proposed Treas. Reg. § 1.956-2(c)(1) provides that a partnership that guarantees an obligation of a U.S. person will be treated as a holding the obligation for purposes of § 956. As a result, proposed Treas. Reg. § 1.956-4(b) will then treat the partners of the partnership that is the pledgor or guarantor as holding shares of that obligation. For example, if a partnership with one CFC partner guarantees an obligation of the CFC's U.S. shareholder, the CFC will be treated as holding a share of the obligation under the proposed regulations.
- (d) Under current Treas. Reg. § 1.956-2(c)(2), a CFC is treated as a pledgor or guarantor of an obligation of a U.S. person if its assets serve at any time, even though indirectly, as security for the performance of the obligation. Consistent with this rule, a partnership should be considered a pledgor or guarantor of an obligation of a U.S. person if the partnership's assets serve indirectly as security for the performance of the obligation, for example, because the partnership agrees to purchase the obligation at maturity if the U.S. person does not repay it. Thus, proposed Treas. Reg. § 1.956-2(c)(2) applies the indirect pledge or guarantee rule to domestic and foreign partnerships.
- (e) In the case of a partnership that is considered a pledgor or guarantor of an obligation under the proposed regulations, Treasury and the IRS believe it would not be appropriate to separately apply the existing Treasury regulation directly to a CFC partner in the partnership to treat the partner as a pledgor or guarantor (in addition to treating the partnership as a pledgor or guarantor) solely as a result of the partnership's indirect pledgor guarantee. Therefore, proposed Treas. Reg. § 1.965-2(c)(2) provides that when a partnership is considered a pledgor or guarantor of an obligation, a CFC that is a partner in the

partnership will not be treated as a pledgor or guarantor of the obligation solely as a result of its ownership of an interest in the partnership. Accordingly, the CFC will be treated under the proposed regulations as holding its share of the obligation to which the pledge or guarantee relates but will not also be treated as a separate and direct pledgor or guarantor of the obligation.

- (f) As discussed above, an obligation of a foreign partnership generally is treated as an obligation of the partners in the partnership. A partner in a partnership is treated as holding its attributable share of property held by the partnership. The application of these two rules in the proposed indirect pledge or guarantee rule could create uncertainty. For example, if a CFC and related U.S. person were the only partners in a foreign partnership that borrowed from a person unrelated to the partners, an issue could arise as to whether the partnership assets attributed to the CFC under proposed Treas. Reg. § 1.956-4(b) are considered under proposed § 1.956-2(c)(2) to indirectly serve as security for the performance of the portion of the partnership obligation that is treated as an obligation of the U.S. person.
- (g) Treasury and the IRS believe that a CFC that is a partner in a partnership should not be treated as a pledgor or guarantor of an obligation of the partnership merely because the CFC partner is treated under the proposed regulations as owning a portion of the partnership assets that support the obligation that is allocated to a partner that is a U.S. person. Accordingly, proposed Treas. Reg. § 1.956-4(d) provides that, for purposes of § 956 and the proposed regulations, if the CFC is a partner in a partnership, the attribution of assets of the partnership to the CFC under the proposed regulations does not in and of itself give rise to an indirect pledge or an indirect guarantee of an obligation of the partnership that is allocated under proposed Treas. Reg. § 1.956-4(c) to a partner that is a U.S. person.
- (h) The preamble states that this rule is consistent with the new rule under proposed Treas. Reg. § 1.956-2(c)(2) providing that a CFC that is a partner in a partnership will not be treated, solely as a result of its interest in the partnership, as a pledgor or guarantor of an obligation with respect to which the partnership is considered to be a pledgor or guarantor. However, the determination of whether a CFC's assets serve as security for the performance of an obligation for purposes of proposed Treas. Reg. § 1.956-2(c)(2) is based on all facts and circumstances. In appropriate circumstances, states the preamble, the existence of other factors, such as the use of proceeds from a partnership borrowing, the use of partnership assets as security for a partnership borrowing, or

special allocations of partnership income or gain, may result in a CFC partner being considered a pledgor or guarantor of an obligation of the partnership pursuant to proposed Treas. Reg. § 1.956-2(c)(2) when taken into account in conjunction with the attribution of the assets of the partnership to the CFC.

- (i) Under current Treas. Reg. § 1.956-1(e)(2), the amount taken into account by a CFC in determining the amount of its U.S. property with respect to a pledge or guarantee described in Treas. Reg. § 1.956-2(c)(2) is the unpaid principal amount of the obligation with respect to which the CFC is a pledgor or guarantor. In connection with the proposed revision to Treas. Reg. § 1.956-2(c)(1), which treats a partnership as holding an obligation with respect to which it is a pledgor or guarantor, the proposed regulations would revise Treas. Reg. § 1.956-1(e)(2) to also apply in cases in which partnerships are pledgors or guarantors of an obligation.
- (j) Accordingly, under proposed Treas. Reg. § 1.956-1(e)(2), as under current law, each pledgor or guarantor is treated as holding the entire unpaid principal amount of the obligation to which its pledge and guarantee relates. As a result, in cases in which there are, regarding a single obligation, multiple pledgors or guarantors that are CFCs or partnerships in which a CFC is a partner, the aggregate amount of U.S. property treated as held by CFCs may exceed the unpaid principal amount of the obligation. To the extent that the CFCs have sufficient earnings and profits, there could be multiple § 951 inclusions with respect to the same obligation that exceed, in the aggregate, the unpaid principal amount of the obligation.
- (k) Treasury and the IRS are considering whether to exercise the authority granted under § 956(e) to prescribe regulations as may be necessary to carry out the purposes of § 956 to allocate the amount of the obligation among the relevant CFCs so as to eliminate the potential for multiple inclusions and, instead, limit the aggregate inclusions to the unpaid principal amount of the obligation. Comments were requested.
- (l) Alternatively, Treasury and the IRS could seek to establish a generally applicable method for allocating unpaid principal amount of the obligation among the various grantors. Allocating the unpaid principal amount of the obligation among multiple CFCs and partnerships in accordance with their available credit capacities, measured, for example, by relative net values of their assets might be broadly consistent with a creditor's analysis of the support for the obligation but such an approach would give rise to

administrability concerns. A more administrable option would be to require taxpayers to allocate the unpaid principal amount based on the earnings and profits of the CFCs that are treated as holding the obligation (or a portion thereof). Several other alternative methods based on earnings and profits also might be possible.

- (m) In considering options, Treasury and the IRS will consider whether it is appropriate to select a method that could result in an aggregate § 951 inclusions for a year totaling less than the unpaid principal amount of the obligation, the extent to which a particular method creates planning opportunities inconsistent with the policies underlying §§ 956 and 959, and how administrable and effective the method is over multiple years.

4. Partnership Property Indirectly Held by a CFC Partner.

- (a) Under current Treas. Reg. § 1.956-2(a)(2), if a CFC is a partner in a partnership that holds property that would be U.S. property if held directly by the CFC partner, the CFC partner is treated as holding an interest in the property based on its interest in the partnership. The proposed regulations provide rules on the determination of the amount that the CFC partner is treated as holding under this rule, which is redesignated under the proposed regulations as Prop. Treas. Reg. § 1.956-4(b).
- (b) Under proposed Treas. Reg. § 1.956-4(b), a CFC partner will be treated as holding its share of partnership property determined in accordance with the CFC partner's liquidation value percentage, taking into account any special allocation of income, or, where appropriate, gain from that property that is not disregarded or reallocated under § 704(b) or any other Code section, regulation, or judicial doctrine that does not have a principal purpose of avoiding the purposes of § 956. Treasury and the IRS believe this rule serves, in general, as a reasonable measure of a partner's interest in property held by a partnership because it generally results in an allocation of specific items of property that corresponds with each partner's economic interest in that property, including any income, or gain, that might be subject to special allocations.
- (c) The proposed regulations include examples illustrating the application of the proposed rule, including an example that illustrates a case in which it is appropriate to take into account the special allocation of gain because the property is anticipated to appreciate in value but generate relatively little income. Although proposed Treas. Reg. § 1.956-4(b) would apply only to property acquired on or after publication of the Treasury Decision adopting the rule as a final regulation, the preamble states that it generally

would be reasonable to use the method set forth in the proposed regulation to determine the partners interest in property acquired prior to finalization as well.

- (d) Although the method provided by the proposed regulations generally should reflect the partner's economic interest in partnership property, Treasury and IRS requested comments on whether there may be situations in which the method would not reflect the partners' economic interest in the partnership or its property.

5. Trade or Service Receivables.

- (a) Section 956(c)(3) provides that U.S. property generally includes trade or service receivables acquired from related U.S. persons in a factoring transaction when the obligor with respect to the receivables is a U.S. person. Temp. Treas. Reg. § 1.956-3T(b)(2) provides rules for determining when a trade or receivable has been indirectly acquired from a related U.S. person for purposes of § 956(c)(3). These provisions include a rule that applies to receivables held on a CFC's behalf by a partnership in which the CFC owns (directly or indirectly) a beneficial interest. This rule is similar to the rule in both current Treas. Reg. § 1.956-2(a)(3) and proposed Treas. Reg. § 1.956-4(b). Temp. Treas. Reg. § 1.956-3T(b)(2) also includes a rule that applies to receivables held on a CFC's behalf by another foreign corporation controlled by the CFC if one of the principal purposes for creating, organizing, or funding the other foreign corporation (through capital contributions or debt) is to avoid the application of § 956.
- (b) Treasury and the IRS believe that the rules in Temp. Treas. Reg. § 1.956-3T(b)(2)(ii) applicable to factoring transactions involving partnerships should be consistent with the rules provided in Temp. Treas. Reg. § 1.956-1T(b)(4) and proposed Treas. Reg. § 1.956-4(b), which generally apply when partnerships own property that would be U.S. property in the hands of a CFC partner. Accordingly, Treasury and the IRS propose to revise the rules governing factoring transactions so that rules similar to the rules in Temp. Treas. Reg. § 1.956-1T(b)(4) and proposed Treas. Reg. § 1.956-4(b) apply to factoring transactions involving partnerships. These proposed regulations also would revise the rules governing factoring transactions to remove the reference to S corporations, which are treated as partnerships for purposes of Subpart F, including § 956. *See* § 1373(a).

6. Disregarded Entities.

- (a) Treasury and the IRS understand that issues have arisen as to the proper treatment under § 956 of obligations of entities that are disregarded as entities separate from their owner for federal tax purposes. Accordingly, the proposed regulations state explicitly in proposed Treas. Reg. § 1.956-2(a)(3) that, for purposes of § 956, an obligation of a disregarded entity is treated as an obligation of the owner of the disregarded entity. Thus, for example, an obligation of a disregarded entity that is owned by a domestic corporation is treated as an obligation of the domestic corporation for purposes of § 956. The rule in proposed Treas. Reg. § 1.956-2(a)(3) follows from an application of the check-the-box rules, and, states the preamble, is therefore not a change from current law.
- (b) This newly proposed rule, which the preamble states is not a change from current law, raises a number of issues. Does it matter if the owner of the disregarded limited-liability entity is not liable at law for repayment? That is, the foreign disregarded entity might be a limited-liability entity. After all, an “obligation of a U.S. person” is necessary to trigger operation of the statute.
- (c) What if the borrowed funds remain with the disregarded entity, are used in its business like bank-loan proceeds, and are paid back with funds earned by the disregarded entity? Should a § 956 investment result if the borrowed funds or comparable amounts are never remitted to or in the possession of the U.S. owner of the disregarded operating entity? What is the purpose of § 956?
- (d) The IRS has consistently adopted the position in regulations and other guidance that a legal entity that has made a check-the-box election to be disregarded should nonetheless be treated as separate from its owner when the law at issue requires that treatment.
- (e) Treas. Reg. § 1.752-2(k) treats owners of disregarded entities that, in turn, own partnership interests as having risk of economic loss with respect to partnership liabilities (giving rise to basis) only to the extent of the disregarded entity’s net value. The rule does not apply if the owner of the disregarded entity is required to make payments with respect to the obligation. Under this reasoning, the U.S. owner of a disregarded foreign entity should not be treated as the obligor on the disregarded entity’s legal obligations if the U.S. company in fact has no liability with respect to those obligations.
- (f) Rev. Rul. 2004-88, 2004-2 C.B. 166, holds that a disregarded LLC that is a general partner in a partnership under state law may be

designated the tax matters partner (“TMP”) to serve as the representative of the partnership in a TEFRA proceeding. Moreover, the LLC’s owner, A, may *not* be considered a general partner by virtue of the LLC’s disregarded status under the check-the-box regulations.

- (g) Under Treas. Reg. § 301.6231(a)(7)-1(b)(1), a partnership may designate a person as the TMP if that person (i) was a general partner in the partnership at some time during the taxable year for which the designation is made, or (ii) is a general partner in the partnership at the time the designation is made. Rev. Rul. 2004-88 states that the check-the-box regulations “do not alter state law, which determines a partner’s status as a general partner.”
- (h) The ruling states that the disregarded entity’s owner, A, “does not become a general partner under state law by operation of the check-the-box rules. Although LLC is a disregarded entity for federal tax purposes, LLC remains a partner in P and is the sole general partner authorized to bind the partnership under state law. . . . Accordingly, A cannot step into the shoes of LLC, the disregarded entity.”
- (i) Under Treas. Reg. § 301.7701-2T, an entity that is otherwise disregarded is treated as an entity separate from its owner for purposes of federal tax liabilities of the entity, and for federal tax liabilities of any other entity for which the entity is liable under state law. The regulation provides the following example (Example 1):

In 2006, X, a domestic corporation that reports its taxes on a calendar year basis, merges into Z, a domestic LLC wholly owned by Y that is disregarded as an entity separate from Y, in a state law merger. X was not a member of a consolidated group at any time during its taxable year ending in December 2005. *Under the applicable state law*, Z is the successor to X and is liable for all of X’s debts. In 2009, the Internal Revenue Service (IRS) seeks to extend the period of limitations on assessment for X’s 2005 taxable year. Because Z is the successor to X and is liable for X’s 2005 taxes that remain unpaid, Z is the proper party to sign the consent to extend the period of limitations (emphasis added).

- (j) The regulation therefore provides that a disregarded entity should (i) be held liable for its own debts, as well as the debts of entities that have merged into it; and (ii) make the decisions that could affect its liabilities under state law, including whether to extend the statute of limitations. The regulation recognizes that it is the

disregarded entity (not the parent) that is liable for its own debts where that is the case under state law.

- (k) Thus, if the U.S. owner of the disregarded limited-liability foreign entity is not an obligor on that debt it would seem the check-the-box regulations cannot make it an obligor. Section 956 needs an “obligation of a U.S. person” before there can be a § 956 investment.

7. Domestic Partnerships. Proposed Treas. Reg. § 1.956-4(e) also confirms that, for purposes of § 956, an obligation of a domestic partnership is an obligation of a U.S. person, regardless of whether the partners in a partnership are U.S. persons. Under § 956(c)(1)(C), an obligation of a U.S. person generally is U.S. property for purposes of § 956 unless an exception in § 956(c)(2) applies to the obligation. For example, § 956(c)(2)(L) would apply to exclude an obligation of a domestic partnership held by a CFC from the definition of U.S. property if neither the CFC nor a person related to the CFC (within the meaning of § 954(d)(3)) were a partner in the partnership.

8. Proposed Effective/Applicability Dates.

- (a) The proposed regulations are to be effective for taxable years of CFCs ending on or after the date of publication in the Federal Register of the Treasury Decision adopting the rules as final regulations, and taxable years of U.S. shareholders in which or with which those taxable years end. Most of these rules are proposed to apply to property acquired, or pledges or guarantees entered into, on or after September 1, 2015, including property considered acquired, or pledges or guarantees considered entered into, on or after September 1, 2015, as a result of a deemed exchange pursuant to § 1001.
- (b) Two rules, however, are proposed to apply to obligations held on or after the date of publication in the Federal Register of the Treasury Decision adopting the rules as final regulations. *See* proposed Treas. Reg. §§ 1.956-2(a)(3) and 1.956-4(e) (dealing with obligations of disregarded entities and domestic partnerships).
- (c) Finally, proposed Treas. Reg. § 1.956-4(b) (dealing with partnership property indirectly held by a CFC) is proposed to apply to property acquired on or after the date of publication in the Federal Register of the Treasury Decision adopting these rules as final regulations.
- (d) No inference is intended as to the application of the provisions proposed to be amended by the proposed regulations under current



law, including transactions involving obligations of foreign partnerships. The IRS may, where appropriate, challenge transactions under currently applicable Code or regulatory provisions or judicial doctrines.

D. Active Rents and Royalties Exception: Temporary Regulations.

1. Rents and royalties generally are included in a CFC's foreign personal holding company income ("Subpart F income"). Rents and royalties derived in the active conduct of a trade or business and received from a person that is not a related person, however, are excluded from Subpart F income. The § 954 regulations provide rules for determining whether rents and royalties are derived in the active conduct of a trade or business for purposes of § 954(c)(2)(A).
2. Specifically, Treas. Reg. § 1.954-2(c) provides four alternative ways for rents to be derived in the active conduct of a trade or business, and Treas. Reg. § 1.954-2(d) provides two alternative ways for royalties to be derived in the active conduct of a trade or business. One way for a CFC to derive rents and royalties in the active conduct of a trade or business is to satisfy an "active development" test which, among other things, requires the CFC to be regularly engaged either in the "manufacture or production of, or in the acquisition and addition of substantial value to," certain property (regarding rents); or in the "development, creation or production of, or in the acquisition of an addition of substantial value to," certain property (regarding royalties) (collectively, the active development tests).
3. Although certain of the alternative ways (specifically, the active management and marketing tests) in which a CFC can satisfy the active rents and royalties exception require the relevant activities be performed by the CFC's own offices or staff of employees, the active development tests do not expressly contain this requirement. Treas. Reg. § 1.954-2(d)(3) Example 5, however, does indicate that royalties received by a CFC that financed independent persons in development activities were not considered derived in the active conduct of a trade or business for purposes of § 954(c)(2)(A).
4. In addition to the active development test, another way for a CFC to derive active rents and royalties in the active conduct of a trade or business is to satisfy an "active marketing" test. The test, among other things, requires the CFC to operate in a foreign country an organization that is regularly engaged in the business of marketing, or marketing and servicing, the leased or licensed property, and that is "substantial" in relation to the amount of rents and royalties derived from the leased or licensed property. Pursuant to a safe harbor, an organization is "substantial" if the active leasing or licensing expenses equal or exceed 25% of the adjusted leasing or licensing profits. The regulations generally define active leasing

expenses and active licensing expenses to mean, subject to certain exceptions, deductions that are properly allocable to rental or royalty income and that would be so allowable under § 162 if the CFC were a domestic corporation.

5. The active rents and royalties exception is intended to distinguish between a CFC that passively receives investment income and a CFC that derives income from the active conduct of a trade or business. Accordingly, the policy underlying the active rents and royalties exception requires that the CFC itself actively conduct the business that generates the rents or royalties. Treasury and the IRS have determined that, consistent with this policy, the CFC must perform the relevant activities (that is, activities related to the manufacturing, production, development, or creation of, or, in the case of an acquisition, the addition to substantial value to, the property at issue) through its own officers or staff of employees in order to satisfy the active development test. Thus, new Temp. Treas. Reg. § 1.954-2T(c)(1)(i) and (d)(1)(i) expressly provide that the CFC lessor or licensor must perform the required functions through its own officers or staff of employees.
6. Treasury and the IRS also have concluded that the policy of the active rents and royalties exception allows the relevant activities undertaken by a CFC through its officers or staff of employees to be performed in more than one foreign country. Thus, new Temp. Treas. Reg. § 1.954-2T(c)(1)(iv) and (d)(1)(ii) provide that a CFC's officers or staff of employees may be located in one or more foreign countries, and an organization that meets the requirements of the active marketing test can be maintained and operated by the officers or a staff of employees either in a single foreign country or in multiple foreign countries collectively. An organization also can be in a single foreign country or in multiple foreign countries collectively for purposes of determining the substantiality of the foreign organization.
7. The preamble states that in applying the active development tests and the active marketing tests, questions have arisen as to the treatment of cost sharing arrangements under which a person other than a CFC actually conducts relevant activities. Consistent with the policy underlying the active rents and royalties exception that requires the CFC itself to conduct the relevant activities, the temporary regulations clarify that cost sharing payments and PCT (buy-in) payments made by a CFC will not cause the CFC's officers and employees to be treated as undertaking the activities of the controlled participant to which the payments are made. This clarification applies for purposes of the active development tests and the active marketing tests, including for purposes of determining whether an organization that engages in marketing is substantial.

8. Similarly, the temporary regulations provide that deductions for cost sharing payments and PCT payments are excluded from the definition of active leasing expenses and active licensing expenses. Thus, the cost sharing payments and PCT payments are not active leasing expenses or active licensing expenses for purposes of determining whether an organization is “substantial” under the safe harbor test.
9. The rules relating to the active development test apply to rents and royalties received or accrued during taxable years of CFCs ending on or after September 1, 2015, and to taxable years of U.S. shareholders in which or with which such taxable years end, but only with respect to property manufactured, produced, developed, or created, or, in the case of acquired property, property to which substantial value has been added, on or after September 1, 2015.
10. The rules regarding the active marketing test, as well as the rules regarding cost-sharing arrangements, apply to rents or royalties received or accrued during taxable years of CFCs ending on or after September 1, 2015, and to taxable years of U.S. shareholders in which or with which those taxable years end, to the extent that these rents or royalties are received or accrued on or after September 1, 2015.

#### IV. PARTNERSHIPS.

##### A. Transfers of Property to Partnerships with Related Foreign Partners.

1. Notice 2015-54 announced that Treasury and the IRS intend to issue regulations under § 721(c) (transfers to partnerships) to ensure that, when a U.S. person transfers certain property to a partnership that has foreign partners related to the transferor, income or gain attributable to the property will be taken into account by the transferor either immediately or periodically. The Notice also states that Treasury and the IRS intend to issue regulations under §§ 482 and 6662 applicable to controlled transactions involving partnerships to ensure the appropriate valuation of property transferred in these transactions.
2. Under the to-be-issued regulations, § 721(a) will not apply when a U.S. transferor contributes an item of § 721(c) Property to a § 721(c) Partnership (and the transfer thus will be fully taxable), unless the Gain Deferral Method set forth in the Notice is applied with respect to the § 721(c) Property.
3. A de minimis rule of \$1 million applies. The de minimis amount is measured as the aggregate of built-in gain with respect to all § 721(c) Property contributed to the § 721 Partnership by related U.S. transferors. The de minimis rule is turned off if the § 721(c) Partnership is applying

the Gain Deferral Method with respect to a prior contribution of § 721(c) Property by the U.S. transferor or a related U.S. transferor.

4. Section 721(c) Property is property, other than Excluded Property, with built-in gain. Excluded Property is (i) cash equivalents, (ii) any asset that is a security within the meaning of § 475(c)(2) without regard to § 475(c)(4), and (iii) any item of tangible property with built-in gain that does not exceed \$20,000.
5. A partnership (domestic or foreign) is a § 721(c) Partnership if a U.S. transferor contributes § 721(c) Property to the partnership, and, after the contribution and any transactions related to the contribution, (i) a related foreign person is a direct or indirect partner in the partnership and (ii) the U.S. transferor and one or more related persons own more than 50% of the interest in partnership capital, profits, deductions or losses.
6. The requirements for applying the Gain Deferral Method are as follows:
  - (a) The § 721(c) Partnership adopts the Remedial Allocation Method described in Treas. Reg. § 1.704-3(d) for built-in gain with respect to all § 721(c) Property contributed to the § 721(c) Partnership pursuant to the same plan by a U.S. transferor and all other U.S. transferors that are related persons.
  - (b) During any taxable year in which there is remaining built-in gain with respect to an item of § 721(c) Property, the § 721(c) Partnership allocates all items of § 704(b) income, gain, loss and deduction with respect to that § 721(c) Property in the same proportion. For example, if income with respect to an item of § 721(c) Property is allocated 60% to the U.S. transferor and 40% to a related foreign person in a taxable year, then gain, deduction and loss with respect to that § 721(c) Property must also be allocated 60% to the U.S. transferor and 40% to the related foreign person.
  - (c) The reporting requirements described in the Notice are satisfied.
  - (d) The U.S. transferor recognizes built-in gain with respect to any item of § 721(c) Property upon an Acceleration Event, as described in the Notice.
  - (e) The Gain Deferral Method is adopted for all § 721(c) Property subsequently contributed to the § 721(c) Partnership by the U.S. transferor and all other U.S. transferors that are related persons until the earlier of: (i) the date that no built-in gain remains with respect to any § 721(c) Property to which the Gain Deferral Method first applied; or (ii) the date that is 60 months after the date

of the initial contribution of the § 721(c) Property to which the Gain Deferral Method first applied.

7. An Acceleration Event with respect to an items of § 721(c) Property is any transaction that either would reduce the amount of remaining built-in gain that a U.S. transferor would recognize under the Gain Deferral Method if the transaction had not occurred or could defer the recognition of the built-in gain. In addition, an Acceleration Event is deemed to occur with respect to all § 721(c) Property of a § 721(c) Partnership for the taxable year of the partnership in which any party fails to comply with all of the requirements for applying the Gain Deferral Method.
8. Upon an Acceleration Event with respect to an item of § 721(c) Property, a U.S. transferor must recognize gain in an amount equal to the remaining built-in gain that would have been allocated to the U.S. transferor if the § 721(c) Partnership had sold the item of § 721(c) Property immediately before the Acceleration Event for its fair market value.
9. In an example, USP, a domestic corporation, wholly owns FS, a foreign corporation. USP and FS form a new partnership, PRS. FS contributes cash of \$1.5 million to PRS, and USP contributes the following three assets: a patent with an arm's length price of \$1.2 M and an adjusted basis of zero; a security with an arm's length price of \$100,000 and adjusted basis of \$20,000; and machine with an arm's length price of \$200,000 and an adjusted basis of \$600,000.
10. Because the patent has built-in gain, it is § 721(c) Property. Although the security has built-in gain, it is excluded property because it is an asset described in § 475(c)(2). Section 721(c) Property is property other than excluded property, with built-in gain. Excluded property is cash equivalents, any asset that is a security within the meaning of § 475(c)(2), and any item of tangible property with built-in gain that does not exceed \$20,000. The machine has a built-in loss and is therefore not § 721(c) Property.
11. Thus, because USP is a U.S. person and not a domestic partnership, USP is a U.S. transferor that has contributed § 721(c) Property. FS is related to USP under § 267(b) and is not a U.S. person. Accordingly, FS is a related foreign person to USP. USP and FS collectively own more than 50% of the interest in capital, profits, deductions and losses of PRS. Therefore, PRS is a § 721(c) Partnership.
12. The de minimis property rule does not apply because the sum of the built-in gain for all § 721(c) Property is \$1.2 million, which exceeds the \$1 million de minimis threshold. The built-in loss in the machine does not factor into determining whether the contribution is below the de minimis threshold.

13. As a result, § 721(a) does not apply to USP's contribution of the patent to PRS unless the Gain Deferral Method is applied.
14. In Example 2, a U.S. transferor contributes § 721 Property to a § 721(c) Partnership in year 1. The property ("Asset 1") has built-in gain of more than \$1 million. FS, a related foreign person, also is a partner. The partnership allocates all items of income, gain, deduction and loss with respect to Asset 1, 60% to USP and 40% to FS and adopts the Remedial Allocation Method with respect to Asset 1. The parties comply with the applicable reporting requirements under § 6038, § 6038B and § 6046A and the regulations thereunder. The parties properly apply the Gain Deferral Method with respect to Asset 1 in years 1 through 3.
15. In an unrelated transaction in year 4, USP contributes § 721(c) Property (Asset 2) with a built-in gain of \$100,000 to the partnership. The partnership allocates all items of income, gain and loss with respect to Asset 2, 20% to USP and 80% to FS, but allocates deductions with respect to Asset 2, 90% to USP and 10% to FS. The partnership adopts the Remedial Allocation Method with respect to Asset 2.
16. In year 4, although Asset 2 has built-in gain of less than \$1 million, the de minimis rule will not apply because the parties are applying the Gain Deferral Method with respect to Asset 1. Because the deductions with respect to Asset 2 are allocated in a different proportion from the other § 704(b) items with respect to Asset 2, the requirements for satisfying the Gain Deferral Method are not met with respect to Asset 2, and USP must recognize the built-in gain with respect to Asset 2.
17. Furthermore, because the Gain Deferral Method does not apply to Asset 2, which was contributed within 60 months of Asset 1, an Acceleration Event is deemed to occur with respect to Asset 1 and USP must recognize any remaining built-in gain with respect to Asset 1.
18. In Example 3, the facts are the same as in Example 2 except that USP does not contribute Asset 2. In year 3, the partners amend the partnership agreement so that all items of income, gain, deduction and loss with respect to Asset 1 are now allocated 30% to USP and 70% to FS. Assume the amendment is accompanied by any consideration required by § 482 and has substantial economic effect as required by § 704(b). Because each § 704(b) item with respect to Asset 1 continues to be allocated in the same proportion to each partner, the Gain Deferral Method will continue to apply so long as the other requirements of the Gain Deferral Method are satisfied.
19. In Example 4, USP, a U.S. transferor, contributes § 721 property (Asset 1) with built-in gain of more than \$1 million to a § 721(c) Partnership (PRS) in which FS, a related foreign person and USX, an unrelated U.S. person,

also are partners. The parties properly apply the Gain Deferral Method with respect to Asset 1. In Year 3, USP transfers all of its assets, including its interest in PRS to USS, a domestic corporation, in the transaction to which § 381 applies. In Year 9 (a year in which there is remaining built-in gain with respect to Asset 1), PRS distributes Asset 1 to FS.

20. Although USP will no longer recognize any remaining built-in gain with respect to Asset 1 under the Gain Deferral Method following the transfer to USS, USS is a successor U.S. transferor. Therefore, provided the requirements of the Gain Deferral Method continue to be satisfied, including treating USS as a U.S. transferor, the transfer of USP's interest in PRS to USS is not an Acceleration Event.
21. Although § 704(c)(1)(B) does not apply to the Year 9 distribution, the distribution is an Acceleration Event because USS will not recognize any remaining built-in gain with respect to Asset 1 under the Gain Deferral Method following the distribution. Therefore, USS must recognize gain in an amount equal to the remaining built-in gain that would have been allocated to USS if PRS had sold Asset 1 immediately before the distribution for its fair market value.
22. In Example 5, the facts are the same as in Example 4 except that in Year 3, instead of USP transferring its assets to USS, PRS instead contributes Asset 1 to FC, a foreign corporation, in a transfer described in § 351(a). There is no distribution in Year 9.
23. For purposes of §§ 367(a) and (d), each partner in PRS that is a U.S. person is treated as having transferred its share of the § 721(c) Property directly to FC. An Acceleration Event occurs, but not to the extent of USP's and USX's shares of the § 721(c) Property. The FC stock received by PRS in the transaction is not subject to the Gain Deferral Method.
24. The Treasury Department and IRS intend to issue regulations regarding the application to controlled transactions involving partnerships of certain rules in Treas. Reg. § 1.482-7 that are currently applicable to cost sharing arrangements. In particular, Treasury and the IRS intend to issue regulations to provide specified methods for controlled transactions based on specified methods in Treas. Reg. § 1.482-7(g), as properly adjusted in light of the differences in facts and circumstances between the partnerships and cost sharing arrangements.
25. The regulations will also provide periodic adjustment rules that are based on the principles of Treas. Reg. § 1.482-7(i)(6) for controlled transactions involving partnerships. The regulations will provide that, in the event of a trigger based on a significant divergence of actual returns from projected returns for controlled transactions involving a partnership, the IRS may

make periodic adjustments to the results of those transactions under a method based on Treas. Reg. § 1.482-7(i)(6)(v), as appropriately adjusted, as well as any necessary corresponding adjustments to § 704(b) or § 704(c) allocations.

26. The Notice also states that § 482 and related penalties apply to controlled transactions involving partnerships. For example, when U.S. and foreign persons under common control enter into a partnership, the amounts of their contributions to and distributions from, the partnership are subject to adjustment in order to reflect arm's length results. Partnership allocations, including allocations under § 704(c), also are subject to adjustment.
27. Accordingly, states the Notice, the amount of a remedial allocation under the Notice for controlled taxpayers that choose a Gain Deferral Method, or the amount of gain recognized if § 721(a) does not apply, potentially will be subject to adjustment by the IRS under § 482.
28. The Notice is effective with respect to transfers occurring on or after August 6, 2015, and to transfers occurring before that date resulting from entity classification elections made under the check-the-box rules that are filed on or after August 6, 2015, that are effective on or before August 2015.
29. Finally, the Notice states that no inference is intended regarding the treatment of transactions described in the Notice under current law, and the IRS may challenge those transactions under applicable Code provisions, Treasury regulations, and judicial doctrines. For example, the IRS may challenge a partnership's adopted § 704(c) method under the anti-abuse rule on Treas. Reg. § 1.704-3(c)(a)(10).

B. Section 956 developments regarding partnerships were discussed in the Subpart F section above.

## V. SECTION 367.

### A. Section 367(d).

1. Treasury and the IRS released important proposed regulations on the treatment of transfers of intangible property by U.S. persons to foreign corporations subject to § 367(d). The proposed regulations eliminate the so-called foreign goodwill exception from the § 367(d) regulations, and limit the § 367(a) active trade or business exception to certain tangible property and financial assets. This would be a huge change,<sup>1</sup> and one with a seriously weak legal underpinning. The new regulation is proposed to be effective immediately, even before a hearing and comments.

---

<sup>1</sup> In Andrew Velarde and Amanda Athanasiou's report, they called the proposed regulation "a *monumental* break from previous practice." 2015 TNT 178-2.



2. Background.

- (a) The preamble to the newly proposed regulations starts with a discussion of current law regarding § 367(d) and the legislative history of § 367(d). The discussion notes that Temp. Treas. Reg. § 1.367(d)-1T(b) generally provides that § 367(d) applies to the transfer of any intangible property, but not to the transfer of foreign goodwill or going concern value (“foreign goodwill exception”). Temp. Treas. Reg. § 1.367(a)-1T(d)(5)(i) generally defines “intangible property,” for purposes of § 367, as knowledge, rights, documents, and other intangible items within the meaning of § 936(h)(3)(B). Temp. Treas. Reg. § 1.367(a)-1T(d)(5)(iii) defines “foreign goodwill or going concern value” as the residual value of a business operation conducted outside of the United States after all other tangible and intangible assets have been identified and valued. The value of the right to use a corporate name in a foreign country is treated as foreign goodwill or going concern value.
- (b) In amending § 367 in 1984, Congress identified problems as arising when “transferor U.S. companies hope to reduce their U.S. taxable income by deducting substantial research and experimentation expenses associated with the development of the transferred intangible and, by transferring the intangible to a foreign corporation at the point of profitability, to ensure deferral of U.S. tax on the profits generated by the intangible.”
- (c) The Senate Finance Committee stated that “The committee contemplates that ordinarily, no gain will be recognized on the transfer of goodwill or going concern value for use in an active trade or business.” The House report contains a similar statement. The Senate Finance Committee and the House Ways & Means Committee each noted that it “does not anticipate that the transfer of goodwill or going concern value developed by a foreign branch to a newly organized foreign corporation will result in an abuse of the U.S. tax system.”
- (d) Treasury and the IRS, however, expressed in the preamble concern regarding how taxpayers interpret § 367 and the regulations thereunder when claiming favorable treatment for foreign goodwill and going concern value.
- (e) They say that under one interpretation, taxpayers take the position that goodwill and going concern value are not § 936(h)(3)(B) intangible property and therefore are not subject to § 367(d) because § 367(d) only applies to § 936(h)(3)(B) intangible property. Furthermore, these taxpayers assert that gain realized

with respect to the outbound transfer of goodwill or going concern value is not recognized under the general rule of § 367(a) because the goodwill or going concern value is eligible for, and satisfies, the active trade or business exception under § 367(a)(3)(A). This, of course, is stated in the legislative history.

- (f) The preamble states that under a second interpretation taxpayers take the position that, although goodwill and going concern value are § 936(h)(3)(B) intangible property, the foreign goodwill exception applies. These taxpayers also assert that § 367(a) does not apply to foreign goodwill or going concern value, either because of § 367(d)(1)(A) (providing that, except as provided in regulations, § 367(d) and not § 367(a) applies to § 936(h)(3)(B) intangible property) or because the active foreign trade or business exception applies.

3. Reasons for Change.

- (a) Treasury and the IRS say they are aware that, in the context of outbound transfers, certain taxpayers attempt to avoid recognizing gain or income attributable to high-value intangible property by asserting that an inappropriately large share (in many cases, the majority) of the value of the property transferred is foreign goodwill or going concern value that is eligible for favorable treatment under § 367.
- (b) Specifically, Treasury and the IRS say they are aware that some taxpayers value the property transferred in a manner contrary to § 482 in order to minimize the value of the property transferred that they identify as § 936(h)(3)(B) intangible property for which a deemed income inclusion is required under § 367(d) and to maximize the value of the property transferred that they identify as exempt from current tax. Treasury and the IRS say that, for example, some taxpayers (1) use valuation methods that value items of intangible property on an item-by-item basis, when valuing the items on an aggregate basis would achieve a more reliable result under the arm's length standard of § 482, or (2) do not properly perform a full factual and functional analysis of the business in which the intangible property is employed.
- (c) This hardly seems to me like something that would support the major change proposed in the regulations.
- (d) Treasury and the IRS are also aware that some taxpayers broadly interpret the meaning of foreign goodwill and going concern value for purposes of § 367. Specifically, although the existing regulations under § 367 define foreign goodwill or going concern

value by reference to a business operation conducted outside of the United States, some taxpayers have asserted that they have transferred significant foreign goodwill or going concern value when a large share of that value was associated with a business operated primarily by employees in the U.S., where the business simply earned income remotely from foreign customers. In addition, some taxpayers take the position that value created through customer-facing activities occurring within the U.S. is foreign goodwill or going concern value.

- (e) Treasury and the IRS have concluded that these taxpayer positions and interpretations raise significant policy concerns and are inconsistent with the expectation, expressed in the legislative history, that the transfer of foreign goodwill or going concern value developed by a foreign branch to a foreign corporation is unlikely to result in the abuse of the U.S. tax system. They considered whether the favorable treatment for foreign goodwill and going concern value under current law could be preserved while protecting the U.S. tax base through regulations expressly prescribing perimeters for the portion of the value of a business that qualifies for the favorable treatment.
- (f) For example, states the preamble, regulations could require that to be eligible for the favorable treatment, the value must have been created by activities conducted outside the U.S. through an actual foreign branch that had been in operation for a minimum number of years and be attributable to unrelated foreign customers. Treasury and the IRS ultimately determined that such an approach would be impractical to administer.
- (g) In particular, while new temporary regulations under § 482 (see below) change the application of § 482 in important respects, the preamble states that there will continue to be challenges in administering the transfer pricing rules whenever the transfer of different types of intangible property gives rise to significantly different tax consequences. The preamble states that as long as foreign goodwill and going concern value are afforded favorable treatment, taxpayers will continue to have incentives to take aggressive transfer pricing positions to inappropriately exploit the favorable treatment of foreign goodwill and going concern value, however defined, and therefore erode the U.S. tax base.

4. Eliminating the Foreign Goodwill Exception and Limiting the Scope of the Active Foreign Trade or Business Exception.

- (a) The preamble states that the proposed regulations would eliminate the foreign goodwill exception under Temp. Treas. Reg.

§ 1.367(d)-1T and limit the scope of property that is eligible for the active foreign trade or business exception generally to certain tangible property and financial assets. Accordingly, under the proposed regulations, when there is an outbound transfer of foreign goodwill or going concern value, the U.S. transferor will be subject to either current gain recognition under § 367(a) or the tax treatment provided under § 367(d). This certainly would be a major change in the law, and one that is at odds with the clear legislative history.

- (b) Proposed Treas. Reg. § 1.367(d)-1(b) provides that § 367(d) applies to an outbound transfer of intangible property, as defined in proposed Treas. Reg. § 1.367(a)-1(d)(5). Proposed Treas. Reg. § 1.367(d)-1(b) does not provide an exception for any intangible property. Proposed Treas. Reg. § 1.367(a)-1(d)(5) modifies the definition of intangible property. The modified definition facilitates both the elimination of the foreign goodwill exception as well as the addition of a rule under which U.S. transferors may apply § 367(d) with respect to certain other outbound transfers of property that otherwise would be subject to § 367(a) under the U.S. transferor's interpretation of § 936(h)(3)(B). The proposed regulations make certain coordinating changes to Temp. Treas. Reg. § 1.367(d)-1T to take into account the elimination of the foreign goodwill exception and the revised definition of intangible property. The proposed regulations also eliminate the definition of foreign goodwill and going concern value under existing Temp. Treas. Reg. § 1.367(a)-1T(d)(5)(iii) because it no longer will be needed.
- (c) In addition, the proposed regulations eliminate the existing rule of Temp. Treas. Reg. § 1.367(d)-1T(c)(3) that limits the useful life of intangible property to 20 years. The preamble states that if the useful life of transferred intangible property exceeds 20 years, the limitation might result in less than all of the income attributable to the property being taken into account by the U.S. transferor. Accordingly, proposed Treas. Reg. § 1.367(d)-1(c)(3) provides that the useful life of intangible property is the entire period during which the exploitation of the intangible is reasonably anticipated to occur, as of the time of the transfer.
- (d) For this purpose, exploitation includes use of the intangible property in research and development. Consistent with the guidance for cost sharing arrangements in Treas. Reg. § 1.482-7(g)(2)(ii)(A), if the intangible property is reasonably anticipated to contribute to its own further development or to developing other intangibles, then the period includes the period reasonably anticipated at the time of the transfer, of exploiting (including use

in research and development) such further development. Consequently, depending on the facts, the cessation of exploitation activity after a specified period of time may or may not be reasonably anticipated.

5. Modifications Relating to the Active Foreign Trade or Business Exception.

- (a) The rules for determining whether property is eligible for the active foreign trade or business exception and whether property satisfies that exception currently are found in numerous regulations under § 367. The proposed regulations combine the active trade or business regulations, other than the depreciation recapture rule, into a single regulation under proposed Treas. Reg. § 1.367(a)-2. The proposed regulations retain a coordination rule to which a transfer of stock or securities in an exchange subject to § 1.367(a)-3 is not subject to Treas. Reg. § 1.367(a)-2. The proposed regulations also make conforming changes to the depreciation recapture rule, and the branch loss recapture rule.
- (b) Although minor wording changes have been made to consolidate some aspects of the active trade or business regulations into a single regulation, the proposed regulations are not intended to be interpreted as making substantive changes to the active foreign trade or business regulation except as otherwise provided in the preamble.
- (c) Under existing regulations, all property is eligible for the active trade or business exception, unless the property is specifically excluded. Treasury and the IRS say that, under this structure, taxpayers have an incentive to take the position that certain intangible property is not described in § 936(h)(3)(B) and therefore not subject to § 367(d) and is instead subject to § 367(a) but eligible for the active foreign trade or business exception because the intangible property is not specifically excluded from the exception.
- (d) Treasury and the IRS believe that providing an exclusive list of property eligible for the active trade or business exception will reduce the incentives for taxpayers to undervalue intangible property subject to § 367(d).
- (e) The proposed regulations provide that only certain types of property are eligible for the active foreign trade or business exception. However, in order for the eligible property to satisfy that exception, the property must also be considered transferred for use in the active conduct of a trade or business outside the U.S.

Specifically, proposed Treas. Reg. § 1.367(a)-2(a)(2) provides the general rule that an outbound transfer of property satisfies the active trade or business exception if (1) the property constitutes eligible property, (2) the property is transferred for use by the foreign corporation in the active conduct of a trade or business outside of the U.S., and (3) the reporting requirements under § 6038B are satisfied.

- (f) Under proposed Treas. Reg. § 1.367(a)-2(b), eligible property is tangible property, a working interest in oil and gas property, and certain financial assets, unless the property is also described in one of the four categories of ineligible property. Thus, *intangible* property cannot qualify as eligible property.
- (g) Proposed Treas. Reg. § 1.367(a)-2(c) lists four categories of property not eligible for the active trade or business exception, which, in general, are (1) inventory or similar property; (2) installment obligations, accounts receivable or similar property; (3) foreign currency or certain other property denominated in foreign currency and (4) certain leased tangible property. These four categories of property not eligible for the active trade or business exception include four of the five categories described in the existing regulations. The category for intangible property is not retained because it will no longer be relevant: intangible property transferred to a foreign corporation pursuant to § 351 or § 361 will not constitute eligible property under proposed Treas. Reg. § 1.367(a)-2(b).
- (h) The proposed regulations also eliminate the exception in existing Temp. Treas. Reg. § 1.367(a)-5T(d)(2) that allows certain property denominated in the foreign currency of the country in which the foreign corporation is organized to qualify for the active trade or business exception if that property was acquired in the ordinary course of business of the U.S. transferor that will be carried on by the foreign corporation.
- (i) Treasury and the IRS have determined that removing the exception from Temp. Treas. Reg. § 1.367(a)-5T(d)(2) is consistent with the general policy of § 367(a)(3)(B)(iii) to require gain to be recognized in an outbound transfer of foreign currency denominated property. Removing the exception will preserve the character, source, and amount of gain attributable to § 988 transactions that otherwise could be lost or changed if the gain were not immediately recognized but instead were reflected only in the U.S. transferor's basis in the stock of the foreign corporation.

- (j) The general rules for determining whether eligible property is transferred for use in the active conduct of a trade or business outside of the U.S. are described in proposed Treas. Reg. § 1.367(a)-2(d). Paragraphs (e) through (h) provide special rules for certain property to be leased after the transfer, a working interest in oil and gas property, property that is re-transferred by the transferee corporation to another person, and certain compulsory transfers of property.
- (k) Proposed Treas. Reg. § 1.367(a)-2(g)(2) does not retain the portion of existing Temp. Treas. Reg. § 1.367(a)-4T(d) that applies to certain transfers of stock or securities. Treasury and the IRS have determined that Treas. Reg. §§ 1.367(a)-3 and 1.367(a)-8 (generally requiring U.S. transferors that own five-percent or more of the stock of the foreign corporation to enter into a gain recognition agreement to avoid recognizing gain on the outbound transfer of stock or securities) adequately carry out the policy of § 367(a) with respect to the transfer of stock or securities.

6. Treatment of Certain Property as Subject to § 367(d).

- (a) Treasury and the IRS note that taxpayers take different positions as to whether goodwill and going concern value are § 936(h)(3)(B) intangible property, as discussed above. The proposed regulations do not address this issue. However, the proposed regulations provide that a U.S. transferor may apply § 367(d) to a transfer of property, other than certain property described below, that otherwise would be subject to § 367(a) under the U.S. transferor's interpretation of § 936(h)(3)(B).
- (b) Under this rule, a U.S. transferor that takes the position that goodwill and going concern value are not § 936(h)(3)(B) intangible property may nonetheless apply § 367(d) to goodwill and going concern value. Treasury and the IRS say this rule will further sound administration by reducing the consequences of uncertainty regarding whether value is attributable to property subject to § 367(a) or property subject to § 367(d).
- (c) The application of § 367(d) in lieu of § 367(a) is available only for property that is not eligible property, as defined in proposed Treas. Reg. § 1.367(a)-2(b) but, for this purpose, determined without regard to proposed Treas. Reg. § 1.367(a)-2(c) (which describes four categories of property explicitly excluded from the active trade or business exception). A U.S. transferor must disclose whether it is applying § 367(a) or (d) to a transfer of this property.

- (d) To implement this new rule under proposed Treas. Reg. § 1.367(a)-1(b)(5) and the removal of the foreign goodwill exception, the proposed regulations revise the definition of the “intangible property” that applies for purposes of §§ 367(a) and (d). As revised, the term means either property described in § 936(h)(3)(B) or property to which a U.S. transferor applies § 367(d) (in lieu of applying § 367(a)). However, for this purpose, and consistent with the existing regulations, intangible property does not include property described in § 1221(a)(3) (generally relating to certain copyrights) or a working interest in oil and gas property.

7. Modifications to Temp. Treas. Reg. § 1.367(a)-1T.

- (a) Temp. Treas. Reg. § 1.482-1T(f)(2)(i) (below) applies to the arm’s length standard under § 482 when it is used in conjunction with other Code provisions, including § 367, in determining the proper tax treatment of controlled transactions. Proposed Treas. Reg. § 1.367(a)-1(b)(3) provides that, in cases where an outbound transfer of property subject to § 367(a) constitutes a controlled transaction, as defined in Treas. Reg. § 1.482-1(i)(8), the value of the property transferred is determined in accordance with § 482 and the regulations thereunder.
- (b) This rule replaces existing Temp. Treas. Reg. § 1.367(a)-1T(b)(3), which includes three rules. One of these rules refers to the sale of property “if sold individually.” Treasury and the IRS are concerned this could be viewed as inconsistent with Temp. Treas. Reg. § 1.482-1T(f)(2)(i)(B), which provides that an aggregate analysis of the transactions may provide the most reliable measure of an arm’s length result under certain circumstances. The other two rules are eliminated either because they duplicate language elsewhere or are no longer necessary.

8. Proposed Effective/Applicability Dates. The regulations are proposed to apply to transfers occurring on or after September 14, 2015, and to transfers occurring before that date, resulting from entity classification elections that are filed on or after that date. Removal of the exception currently in Temp. Treas. Reg. § 1.367(a)-5T(d)(2) will apply to transfers occurring on or after the date that the rules proposed are adopted as final regulations. No inferences are intended regarding the application of the provisions proposed to be amended by the proposed regulations under current law. The IRS may, where appropriate, challenge transactions under applicable provisions or judicial doctrines.



9. Comments.

- (a) The proposed regulation is impossible to reconcile, and is at odds, with the clear, relevant legislative history, as discussed by Treasury and the IRS in the regulation's preamble. Treasury and the IRS obviously have decided they don't like the foreign goodwill exception.
- (b) The Obama Administration has proposed to change the law to include goodwill, going concern value and workforce-in-place in § 936(h)(3)(B). At first, the Administration's description referred to this change as a "clarification." A New York State Bar Association ("NYSBA") report dated October 12, 2010 stated that calling the change a "clarification" was inconsistent with the legislative history of § 367(d). See the NYSBA report at p. 8. In the two most recent Administration budgets, the assertion that this change would be a "clarification" was dropped. These proposals were never enacted.
- (c) In any event, the new regulation effectively forces taxpayers to treat goodwill and going concern value as § 367(d) assets, and precludes them from qualifying for the active trade or business exception.
- (d) The legislative history, as discussed in the regulation's preamble, is clear that "no gain will be recognized on the transfer of goodwill and going concern value for use in an active trade or business." The proposed regulation obviously is contrary to the statute's legislative history.
- (e) One of the more interesting things about this proposed regulation is that it was issued so closely in time to the Tax Court's decision in *Altera Corporation v. Commissioner*, 145 T.C. No. 3 (2015), discussed in last month's column. The Tax Court looked to the Administrative Procedure Act ("APA") to test the validity of a regulation. The standard under the APA is "arbitrary, capricious and an abuse of discretion or otherwise not in accordance with the law." The reviewing court must ensure that the agency "engaged in reasoned decision making." There must be "an exchange of views, information and criticism between interested parties and the agency."
- (f) The regulation also could have problems under the U.S. Supreme Court's 2014 decision in *Utility Air Regulatory Group v. Environmental Protection Agency*, \_\_\_ U.S. \_\_\_ (2014), which held that an administrative "agency may not rewrite clear statutory terms to suit its own sense of how the statute should operate."

B. Section 367 GRAs.

1. Treasury and the IRS issued final regulations in November 2014 (generally adopting previously proposed regulations) that amend the rules governing failures to file gain recognition agreements and related documents, or to satisfy other reporting obligations, associated with transfers of property to foreign corporations.
2. The § 367(a) regulations provide exceptions to the general income-recognition rule of § 367(a) for certain transfers by a U.S. transferor of stock or securities to a foreign corporation. These exceptions generally require the U.S. transferor to file a GRA and other related documents. Under the terms of a GRA, the U.S. transferor must agree to include in income the gain realized but not recognized on the initial transfer of stock or securities and to pay interest on any additional tax due if a gain recognition event occurs during the five-year term of the GRA.
3. A failure to comply with the GRA rules can trigger gain recognition. An example is the failure to file an annual certification. The previous regulations provided that if there was a failure to comply with the GRA rules, the U.S. transferor would have to recognize the full amount of gain realized on the initial transfer of stock or securities unless the transferor could demonstrate that the failure was due to reasonable cause and not willful neglect under Treas. Reg. § 1.367(a)-8(p). Similarly, if there was a failure to timely file a GRA in connection with the initial transfer, the U.S. transferor must recognize gain with respect to the transfer unless the reasonable cause exception is satisfied.
4. A domestic target corporation in certain cases also must file statements in connection with the transfer by its shareholders or security holders of stock or securities in a domestic target corporation to a foreign corporation under Treas. Reg. § 1.367(a)-3(c). A domestic target also must file a statement when its assets are transferred to a foreign acquiring corporation in a § 361 exchange and all or a portion of those assets are subsequently transferred to a domestic subsidiary of the foreign acquiring corporation in a transaction treated as an indirect stock transfer under Treas. Reg. § 1.367(a)-3(d).
5. In addition, a U.S. person who transfers property to a foreign corporation in certain nonrecognition transactions also is subject to the reporting requirements of § 6038B. The U.S. transferor generally is required to file IRS Form 926, "Return by a U.S. Transferor of Property to a Foreign Corporation." The form must identify the transferee foreign corporation and describe the property transferred. The penalty for failure to satisfy the § 6038B reporting requirement is equal to 10% of the fair market value of the property at the time of the exchange, but not to exceed \$100,000 unless the failure was due to intentional disregard of the reporting

obligations. If the U.S. transferor demonstrates that the failure was due to reasonable cause and not willful neglect, however, no penalty is imposed.

6. Section 367(e)(2) provides that in a liquidation to which § 332 applies, §§ 337(a) and (b)(1) (corporate-level gain exceptions) will not apply when the 80-percent distributee is a foreign corporation unless regulations provide otherwise. As a result, if a domestic liquidating corporation liquidates into a foreign parent corporation (an outbound liquidation), or if a foreign liquidating corporation liquidates into a foreign parent corporation (a foreign-to-foreign liquidation), the liquidating corporation generally must recognize gain or loss on the distribution as if the property were sold to the distributee at its fair market value.
7. Treas. Reg. § 1.367(e)-2(b)(1) provides that a domestic liquidating corporation must recognize gain or loss in an outbound liquidation, subject to an overall loss limitation, except to the extent it satisfies one of the exceptions provided in that regulation. The exceptions are for distributions of (1) property used in the conduct of a trade or business in the U.S.; (2) a U.S. real property interest; or (3) stock of a domestic subsidiary corporation that is at least 80% owned by the domestic liquidating corporation.
8. The regulations also address foreign-to-foreign liquidations and provide that a foreign liquidating corporation generally is not required to recognize gain or loss on the distribution, except in the case of certain distributions of property used in a U.S. trade or business or formerly used in a U.S. trade or business.
9. Other than the exception for distributions of a U.S. real property interest, the exceptions provided under the § 367(e)(2) regulations require the filing of certain statements or schedules by the liquidating corporation and the distributee corporation. A domestic liquidating corporation that distributes property to a foreign corporation in a transaction subject to § 367(e)(2) also must file a Form 926 with respect to the distribution.
10. Under the previous regulations, if a transferor failed to timely file an initial GRA, or failed to comply in any material respect with the § 367(a) GRA regulations with respect to an existing GRA (for example, because it failed to timely file an annual certification), the U.S. transferor was subject to full gain recognition under § 367(a) unless the U.S. transferor later discovered the failure, promptly filed the GRA or other required information with the IRS, and demonstrated that its failure was due to reasonable cause and not willful neglect.
11. Treasury and the IRS were concerned that the previous reasonable cause standard might not be satisfied by U.S. transferors in many common situations even though the failure was not intentional and not due to

willful neglect. Treasury and the IRS believe that full gain recognition under § 367(a) should apply only if a failure to timely file an initial GRA or a failure to comply with a § 367(a) GRA regulations with respect to an existing GRA is willful. They believe that the penalty imposed by § 6038B generally should be sufficient to encourage proper reporting and compliance.

12. The new regulations thus revise the § 367(a) GRA regulations to provide that a U.S. transferor seeking either to (1) avoid recognizing gain under § 367(a) on the initial transfer as a result of a failure to timely file an initial GRA, or (2) avoid triggering gain as a result of a failure to comply in all material respects with the § 367(a) GRA regulations or the terms of an existing GRA, must demonstrate that the failure was not a willful failure.
13. For this purpose, the term “willful” is to be interpreted consistent with the meaning of that term in the context of other civil penalties (for example, § 6672), which would include a failure due to gross negligence, a reckless disregard, or willful neglect.
14. Whether a failure is willful will be determined based on all the relevant facts and circumstances. The regulations illustrate the application of this standard to a series of helpful examples. For example, the § 367(a) GRA regulations require a GRA to include information about the adjusted basis and fair market value of the property transferred. Filing a GRA and intentionally not providing this information, including noting on the GRA that this information is “available upon request,” would be a willful failure.
15. The new regulations also provide guidance clarifying when an initial GRA is considered timely filed, and what gives rise to a failure to comply in any material respect with the requirements of the § 367(a) GRA regulations or the terms of an existing GRA. In general, an initial GRA is timely filed only if each document that is required to be filed as part of the initial GRA is timely filed and complete in all material respects. Similarly, in general, there is a failure to comply in a material respect with the § 367 GRA regulations or the terms of an existing GRA if a document (such as an annual certification) that is required to be filed is not timely filed, or is not completed in all material respects.
16. The revised regulations also clarify that the § 6038B penalty will apply to a failure to comply in any material respect with the § 367(a) GRA regulations or the terms of an existing GRA, such as a failure to properly file a GRA document (including an annual certification or new GRA). Under the new regulations, a failure to comply has the same meaning for purposes of the § 367(a) GRA regulations and the § 6038B regulations.

17. However, the previous reasonable cause standard continues to apply to U.S. transferors seeking relief from the § 6038B penalty.
18. The new regulations also modify the information that must be reported with respect to a transfer of stock or securities on Form 926. Specifically, the U.S. transferor must include on Form 926 the basis and fair market value of the property transferred. In addition, the new regulations require that a Form 926 be filed in all cases in which a GRA is filed.
19. The § 367(e)(2) regulations governing liquidating distributions to foreign parent corporations contain several rules that condition nonrecognition treatment upon the filing of statements or other documents, or complying with the requirements of those regulations' documents are functionally similar to GRAs in certain respects. The previous § 367(e)(2) regulations did not provide explicit guidance regarding the treatment of taxpayers who fail to file these documents or report the required information. They also did not provide a mechanism to obtain relief for any failures.
20. Treasury and the IRS believe that the changes made by the new regulations in the case of § 367(a) transfers are also appropriate for failures to file or failures to comply for purposes of the § 367(e)(2) regulations and the related § 6038B regulations. Accordingly, the new regulations provide rules similar to the rules under the § 367(a) GRA regulations and related § 6038B regulations for failures to file the required documents or statements and failures to comply under the § 367(e)(2) regulations and related § 6038B regulations. Finally, the regulations modify the information that must be reported with respect to one or more liquidating distributions of property, including the addition of a requirement to report the basis and fair market value of the property distributed.
21. The previous § 367(a) regulations did not address a taxpayer's failure to file certain other statements required under Treas. Reg. § 1.367(a)-3 in connection with certain transfers of stock or securities. These include statements required to be filed by a domestic target corporation in connection with a transfer of stock or securities of that corporation to a foreign corporation as described in Treas. Reg. §§ 1.367(a)-3(c)(6) and (7), and the statement required to be filed by a domestic target corporation in connection with the transfer of its assets to a foreign corporation in an exchange described in § 361 and the subsequent transfer of those assets to a domestic subsidiary in a transaction described in Treas. Reg. § 1.367(a)-3(d)(2)(vi)(B)(1)(ii).
22. Treasury and the IRS believe that failures to timely file these statements or failures to comply in all material respects with these regulations should be treated similarly to the failures to file or failures to comply with the

§ 367(a) GRA regulations. Accordingly, the new regulations incorporate similar rules with respect to these other filing obligations.

23. The final regulations' examples are helpful, and are the same as or very similar to the examples in the proposed regulations. *See* Treas. Reg. § 1.367(a)-8(p)(3). In Example 1, the taxpayer failed to file a GRA due to an accidental oversight. DC (domestic corporation) filed its tax return for the year of the FS (foreign subsidiary) transfer, reporting no gain with respect to the exchange of the FS stock. DC, through its tax department, was aware of the requirement to file a GRA, and had experience and competency to prepare the GRA. DC had filed many GRAs over the years and had never failed to timely file a GRA. However, although DC prepared the GRA with respect to the FS transfer, it was not filed with DC's return for the relevant tax year due to an accidental oversight. During the preparation of the following year's tax return, DC discovered that the GRA had not been filed and prepared an amended return to file the GRA and comply with the necessary procedures. The example concludes that the failure to timely file was not a willful failure to file.
24. In Example 2, the taxpayer's course of conduct is taken into account in the determination. DC filed its tax return for the year of the FS transfer, reporting no gain with respect to the exchange of the FS stock, but failed to file a GRA. DC, through its tax department, was aware of the requirement to file a GRA in order for DC to avoid recognizing the relevant gain. However, DC had not consistently and in a timely manner filed GRAs in the past, and also had an established history of failing to timely file other tax and information returns for which it had been subject to penalties.
25. At the time of an FS2 transfer, DC was already aware of its failure to file the GRA required for a prior transfer, but had not implemented any safeguards to ensure that it would timely file GRAs for future transactions. DC's course of conduct is taken into account in determining whether its failure to timely file a GRA for the FS2 transfer was willful. Based on the facts in this example, including DC's history of having failed to file required tax and information returns in general, and GRAs in particular, and its failure to implement safeguards to ensure that it would timely file GRAs, the failure to timely a GRA with respect to the FS2 transfer rises to the level of a willful failure to timely file.
26. In Example 3, the GRA was not completed in all material respects. DC timely filed its tax return for the year of the FS transfer, reporting no gain. DC was aware of the requirement to file a GRA to avoid recognizing gain under § 367(a), including the requirement to provide the fair market value of the transferred stock. Instead, the GRA was filed with the statement that the fair market value information was "available upon request." Other than the omission of the fair market value of the FS stock, the GRA

contained all other information required by that section. Because DC knowingly omitted such information, DC's omission is a willful failure to timely file a GRA. The result would be the same if DC knowingly omitted basis information even if fair market value was included.

27. In Example 4, a GRA is filed as a result of hindsight. At the time DC filed its tax return for the year of the FS transfer, DC anticipated selling Business A in the following year, which was expected to produce a capital loss that could be carried back to fully offset the gain recognized on the FS transfer. DC chose not to file a GRA but to recognize gain on the FS transfer under § 367(a), which it reported on its timely filed tax return. However, a large class action lawsuit was filed against Business A at the end of the following year, and DC was unable to sell the business. As a result, DC did not realize the expected capital loss, and was not able to offset the gain from the FS transfer. DC now seeks to file a GRA for the transfer. Because DC knowingly chose not to file a GRA for the FS transfer, its actions constitute a willful failure to timely file a GRA. Accordingly, the GRA is not considered timely filed and DC must recognize the full amount of the gain realized on the FS transfer.

28. Changes From the Proposed Regulation. While the proposed regulations were generally adopted as final, there were some changes. The most significant changes include:

(a) The proposed regulations under § 6038B required a U.S. person that transfers property to a foreign corporation to file Form 926 with respect to the transfer of stock or securities in all cases in which a GRA is filed in order to avoid penalties under § 6038B. The proposed regulations did not require the U.S. transferor to report any specific information regarding the transferred stock or securities. The final regulations require the U.S. transferor to report the fair market value, adjusted basis and gain recognized in the context of the transfer of stock or securities, as well as any other information required by Form 926 and its accompanying instructions or other applicable guidance. This is similar to the information that must be provided for other types of transferred property.

(b) The final regulations extend the relief for failures that are not willful to certain other reporting obligations under § 367(a) that were not covered by the proposed regulations. Accordingly, revisions to Treas. Reg. § 1.367(a)-2 (providing an exception to gain recognition under § 367(a)(1) for assets transferred for use in the active conduct of trade or business outside the U.S.) and § 1.367(a)-7 (regarding the application of § 367(a) to an outbound transfer of assets by a domestic target corporation in an exchange described in § 361) provide that the taxpayer may, solely for

purposes of § 367(a), be deemed not to have failed to comply with its reporting obligations by demonstrating that the failure was not willful.

Situations in which relief is sought under Treas. Reg. § 1.367(a)-2 and many situations in which relief is sought under Treas. Reg. § 1.367(a)-7 are also subject to reporting under § 6038B and the regulations thereunder. The preamble to the new regulations states that the penalty imposed under § 6038B for failure to satisfy reporting obligations should generally be sufficient to encourage proper reporting and compliance.

- (c) In 2010, the IRS Deputy Commissioner International (LMSB) issued a directive permitting taxpayers to remedy unfiled or deficient GRA documents associated with the timely filed GRA or a timely filed document purporting to be an initial GRA. The directive explained that the means to best ensure compliance with the GRA provisions was under study and that, pending the study, the directive would be effective “until further notice.” Because the new regulations provide comprehensive guidance that is designed to ensure compliance with the GRA requirements, the LMSB directive was revoked on the date the final regulations were published as final in the Federal Register.

29. Other Changes.

- (a) Under the Prop. Treas. Reg. § 1.367(a)-8(p), the regulations were only to apply to requests for relief submitted on or after the date the proposed regulations were adopted as final regulations. Treasury and the IRS have determined that it would be appropriate to provide relief for certain failures to file or comply that were not willful and that were the subject of requests for relief submitted under Treas. Reg. § 1.861(a)-8(p) of the existing regulations before the finalization of the new regulations. Accordingly, the new regulations provide a procedure under which U.S. transferors may resubmit certain previously filed requests.
- (b) Under Prop. Treas. Reg. § 1.367(a)-8(p)(2)(i), a U.S. transferor that seeks relief for a failure to file or failure to comply with the GRA rules must, among other requirements, file an original Form 8838, Consent to Extend the Time to Assess Tax Under § 367 – Gain Recognition Agreement, with an amended return. The final regulations provide that if a U.S. transferor has already filed such a form, it need not file another form with the amended return. Rather, the U.S. transferor must attach a copy of the previously filed Form 8838 to the amended return.



- (c) Treas. Reg. § 1.367(a)-8(j)(8) of the existing regulations provides that a failure to comply with the GRA provisions will extend the statute of limitations until the close of the third full taxable year ending after the date on which the Director of Field Operations or Area Director receives actual notice of the failure to comply from the U.S. transferor. The same provision was set forth in the proposed GRA regulations regarding liquidation documents.
- (d) According to the preamble to the final regulations, the extended period of limitations should be based on when the taxpayer furnishes to the Director of Field Operations International, Large Business & International (or any successor to the roles and responsibilities of that person) the information that should have been provided under those regulations. Thus, those rules were modified accordingly.
- (e) The regulations also were revised to clarify that when a taxpayer files a GRA under Treas. Reg. § 1.367(a)-8 or a liquidation document under Treas. Reg. § 1.367(e)-2, the taxpayer agrees to extend the statute of limitations in the circumstances provided in Treas. Reg. §§ 1.367(a)-8(j)(8) and 1.367(e)-2(e)(4)(ii)(B), as applicable. This agreement is deemed consented to and signed by the IRS for purposes of § 6501(c)(4).
- (f) Treas. Reg. § 1.367(a)-3(a) of the existing final regulations provides a general rule that a U.S. person must recognize gain on certain transfers of stock or securities to a foreign corporation. Treas. Reg. § 1.367(a)-3(c) contains an exception for certain transfers of stock and securities of a domestic corporation. That regulation provides that, except as set forth in Treas. Reg. § 1.367(a)-3(e) (providing rules for transfers of stock or securities by a domestic corporation to a foreign corporation pursuant to an exchange described in § 361), a transfer of stock or securities of a domestic corporation by a U.S. person to a foreign corporation that would otherwise be subject to gain recognition under § 367(a) will not be subject to § 367(a) if certain requirements are satisfied.
- (g) In particular, the domestic corporation the stock or securities of which are transferred (referred to as the U.S. target company) must comply with certain reporting requirements and satisfy four specified conditions. The condition in Treas. Reg. § 1.367(a)-3(c)(1)(iv) requires that an active trade or business test be satisfied. To satisfy the active trade or business test, a substantiality test must be satisfied (among other requirements). The test is satisfied if, at the time of the transfer, the fair market value of the transferee foreign corporation is at least equal to the fair market value of the U.S. target company.

- (h) Pursuant to the reporting requirements contained in Treas. Reg. § 1.367(a)-3(c)(6)(i)(F)(3), the U.S. target company must submit a statement demonstrating that the value of the transferee foreign corporation exceeds the value of the U.S. target company on the acquisition date. The standard that applies for purposes of that reporting requirement is intended to be the same as the standard that applies for purposes of the substantiality test itself. Accordingly, Treas. Reg. § 1.367(a)-3(c)(6)(i)(F)(3) was revised so that the U.S. target company must submit a statement demonstrating that the value of the transferee corporation equals or exceeds the value of the U.S. target company on the acquisition date.

30. Changes Not Made.

- (a) Treasury and the IRS declined to make two changes that were requested by certain commentators. One comment requested that the final regulations excuse Coordinated Industry Case (“CIC”) taxpayers from the requirement under Treas. Reg. § 1.367(a)-8(p)(2) of filing an amended return promptly after discovering a failure to file or a failure to comply. The commentator suggested that instead, the final regulations should allow CIC taxpayers to submit the materials required when the taxpayer effects a “qualified amended return” under Rev. Proc. 94-69, 1994-2 C.B. 804. As noted, Treasury and the IRS declined to adopt this comment.

31. Another commentator suggested that the final regulations provide a mechanism under which taxpayers may modify the fair market value of transferred stock or securities reported on a previously filed GRA. According to the commentator, taxpayers often determine the fair market value of stock or securities before the date that the stock or securities are transferred to the foreign corporation and that these determinations are based on projected financial information that may, in some cases, deviate from the actual financial information on the date of the transfer. As noted, Treasury and the IRS also declined to adopt this comment.

VI. OTHER DEVELOPMENTS.

A. International Exam Capacity; New IRS Slides.

- 1. An IRS official, Douglas O’Donnell, LBI Deputy Commissioner (International), stated that the IRS intends to create a more agile audit function by retraining a portion of its domestic examiners to handle international issues as well. Apparently in connection with this new direction, the IRS made public a number of international training slides developed by its International Practice Networks. O’Donnell mentioned

the slides. The slides describe “best practices” for specific international issues and are among the internal training materials made available to examiners. The slide set is quite lengthy and worth perusing. See <http://www.irs.gov/Businesses/Corporations/International-Practice-Units>.

2. In discussing § 367(d), the slides include a discussion of Chief Counsel Advice 201321018, which is potentially applicable in the context of certain acquisitions that result in a transfer of IP offshore (but curiously the slides do not cite Notice 2012-39, which says the regulations will be revised prospectively to address those transactions). The CCA has been criticized for the IRS’s trying to rewrite the current regulations in a CCA and for seeking to apply the 2012 Notice retroactively.
3. The “Intangible Property Transfers W/O Cost Sharing” slides ask in the context of manufacturing “shifted” to a CFC, were the technical workers also moved to the CFC? It continues,

“as long as the licensed IP has substantial value independent of the services then it is considered intangible property under IRC § 936(h)(3)(B). On the other hand, if the intangible property does not have substantial value independent of the services it must be analyzed as the rendering of services under § 482.”
4. The “§ 482 Fundamentals” slides state that the IRS examiner should consider the “functions performed, assets employed, and risks assumed.” It refers to the recent “Transfer Pricing Roadmap.” It also states that the arm’s length range can be determined “either on a full range or an interquartile range,” depending upon the application of certain criteria.
5. Numerous additional “International Practice Units” have since been issued.

#### B. Integrated Hedging Transactions.<sup>2</sup>

1. In 2012, Treasury and the IRS issued temporary regulations that revised the legging out rules of Treas. Reg. § 1.988-5(a)(6)(ii) applicable to hedging transactions under § 988(d). A public hearing was neither requested nor held. One comment was received, and after consideration of the comment, the temporary regulations were adopted as final without substantive change.
2. The regulation is designed to prevent “legging out” under the § 988(d) integration rules in a manner that would potentially enable taxpayers to recognize a loss with respect to one hedge on a hedged debt instrument

---

<sup>2</sup> Thanks to Larissa Neumann of Fenwick & West for her helpful comments.

without recognizing the corresponding gain on related hedges and the underlying foreign currency debt instrument.

3. The regulations illustrate the new rule with an example, new Example No. 11. In the example, the taxpayer incurs a foreign currency borrowing and hedges it with a currency swap and an interest rate swap. The taxpayer identifies the borrowing and the swap contracts as a qualified hedging transaction under the § 988(d) rules. Later, the taxpayer terminates the interest rate swap and seeks to claim a loss. Under the new regulation, the remaining components of the hedge that have not been disposed of or otherwise terminated must be treated as sold for their fair market values on the leg out date.
4. The example also illustrates an alternative situation in which the taxpayer terminates the interest rate swap at a gain. If 50% or more of the remaining foreign currency cash flows with respect to the borrowing remain hedged at that time, the gain will be recognized and the remaining components of the hedging transaction will not be recognized. That is, in large measure the rule operates in the context of losses, but not gains.
5. Background and Commentary.
  - (a) The New York State Bar Association Tax Section (“NYSBA”) prepared an excellent report on the temporary regulation dated November 13, 2012. In the NYSBA’s view, the targeted hedging position itself is inconsistent with the purposes of § 988(d) and the economic substance of the transaction. The report also expressed the view that it is unlikely a court would sustain the targeted hedging position as qualifying under § 988(d) even under the previous final regulations.
  - (b) The NYSBA also questioned whether the approach taken by the temporary regulations (and by the previous final regulations) is optimal, particularly in light of (1) the meaningfully different approach to similar issues taken by Treas. Reg. § 1.1275-6 and (2) the resulting potential for different tax treatment of economically similar or identical transactions at the option of the taxpayer (or inadvertently by an unwary taxpayer) as a result of these differences.
  - (c) In the view of the NYSBA, the approach to leg outs taken by Treas. Reg. § 1.1275-6 as simpler and more consistent with economic reality and recommended that Treasury and the IRS modify the temporary § 988(d) regulations to adopt that approach. (Treas. Reg. § 1.1275-6 also covers the integration of certain hedging transactions.)

- (d) An important threshold question is whether it is possible under Treas. Reg. § 1.988-5(a) to integrate a debt instrument denominated in a nonfunctional currency with both a currency swap into dollars and a dollar interest rate swap of that same debt. The NYSBA notes that § 988(d)(1) provides that “the extent provided in regulations, if any § 988 transaction is part of a § 988 hedging transaction, all transactions which are a part of such § 988 hedging transactions shall be integrated and treated as a single transaction or otherwise consistently for purposes of this subtitle.” Section 988(d)(2) defines a “section 988 hedging transaction” as a transaction entered into by the taxpayer *primarily* to manage the risk of currency fluctuations.
- (e) While Treas. Reg. § 1.988-5(a) does not explicitly require that all or any of the hedge components manage currency risk, the regulation could be viewed as overly broad in this regard. It also raises a number of questions. The NYSBA, for example, stated in 1992 when the § 988(d) regulations were first adopted that the scope of the regulation appeared significantly more broad than the statutory authorization. *See* the NYSBA Tax Section Report on the Final and Proposed Regulations Dated October 21, 1992 (Tax Notes International, November 4, 1992).
- (f) Treasury and the IRS, in any event, now seem to have confirmed (in the new regulation) that a non-currency interest rate swap can be integrated with a related foreign currency debt instrument under § 988(d). Arguably, this expansion in Example No. 11, if indeed it is a new expansion, may have created the very problem that the Treasury and the IRS now seek to cure.
- (g) The NYSBA asked whether (and what metrics would govern whether) that combination must *primarily* manage the taxpayer’s currency risk with respect to the foreign currency debt, a requirement under the statute. The regulations (both the temporary and previous final regulations) are silent on these points, including whether they are even relevant.
- (h) In an article published shortly after the new temporary regulations were issued, Mark Leeds of Mayer Brown was quoted as stating that the interest rate swap should be eligible for integration only under Treas. Reg. § 1.1275-6, and not under Treas. Reg. § 1.988-5, *even if* the hedge of which it is a component primarily manages currency risk. *See*, Amy Elliott’s report, “Treasury Stops Abusive Foreign Currency Hedging Transactions,” Tax Notes International, September 10, 2012.

- (i) Leeds states he would have designated the currency swap as a hedge under Treas. Reg. § 1.988-5 and the interest rate swap as a hedge under Treas. Reg. § 1.1275-6. He expressed surprise that Treasury and the IRS did not incorporate Treas. Reg. § 1.1275-6 into its guidance.
- (j) In the NYSBA's view, even assuming that a combination of the currency swap and the interest rate swap were properly integratable with the foreign currency debt under Treas. Reg. § 1.988-5(a), the regulations still may not have supported claiming a leg-out loss in the targeted hedging transaction.
- (k) Further, even if a termination of the interest rate swap were to trigger a deemed sale of the foreign currency debt instrument and/or the currency swap, this does not necessarily provide for the recognition of any loss by the taxpayer with respect to the foreign currency debt, assuming it was issued by the taxpayer. As a general principle of tax law, the sale of a debt instrument has no tax consequences for the issuer of the instrument. Therefore, under a literal reading of the regulations, the issuer of an instrument such as the taxpayer in Example No. 11, if it continued to be the obligor under foreign currency debt instrument, would recognize no income or loss with respect to the debt instrument as a result of legging out of the integrated transaction.
- (l) The NYSBA contrasted this result with Treas. Reg. § 1.1275-6(d)(2)(i)(B) which treats a taxpayer that legs out of an integrated transaction as selling "or otherwise terminating" the synthetic debt instrument. This would seem to trigger the result desired by Treasury and the IRS.
- (m) Another issue involves the § 1092 straddle rules. These rules could defer the leg-out loss. The NYSBA, however, believes that it is not entirely clear under the regulations whether the straddle rules would apply to require deferral (or capitalization) of any loss realized on a deemed disposition of the foreign currency debt instrument. Certain ambiguous statements in the § 988(d) regulations cause this lack of clarity.
- (n) The question of which regulation must be applied and the ambiguities regarding how to deal with underlying uncertainties in the regulations in the context of a hedge such as the one described in Example No. 11 suggests that Treasury and the IRS ought to simplify the rules. The way things are now, an unwary taxpayer easily could walk down the wrong path, make an incorrect identification, or misjudge the tax consequences in making certain

business decisions. And the Service could end up making up the rules as it goes along, perhaps to the surprise of all taxpayers.

6. Discussion in Preamble.

- (a) The preamble to the final regulations states that the only comment received (the NYSBA report, discussed above) suggested that promulgation of temporary regulations was unnecessary because the prior regulations did not support the taxpayer reporting position that the temporary regulations were designed to prevent. The preamble states that although the NYSBA thought the temporary regulations ultimately unnecessary, its report acknowledged that the § 988 hedging rules are a complicated area of law and that the prior regulations could be improved to provide greater certainty to taxpayers. Treasury and the IRS thus determined that the temporary regulations are useful in clarifying the § 988(d) integration rules -- as well as preventing unintended approaches to legging out under those rules -- and thus should be adopted as final.
- (b) The NYSBA's report recommended that Treasury and the IRS consider aligning the hedge integration regime under § 988 with the approach taken in the regulations under § 1275 on the basis that the § 1275 approach is more consistent with economic reality. Treas. Reg. § 1.1275-6 generally allows the integration of a qualifying debt instrument with a hedge or combination of hedges if the combined cash flows of the components are substantially equivalent to the cash flows on a fixed or variable rate debt instrument. However, states the preamble, a financial instrument that hedges currency risk cannot be integrated as a Treas. Reg. § 1.1275-6 hedge. *See* Treas. Reg. § 1.1275-6(b)(2).
- (c) Under the legging out rules of Treas. Reg. § 1.1275-6, a taxpayer that legs out of an integrated transaction is treated as terminating the synthetic debt instrument for its fair market value and recognizing any gain or loss. If the taxpayer remains liable on the qualifying debt instrument after the leg-out, adjustment are made to reflect any difference between the fair market value of the qualifying debt instrument and its adjusted issue price. If the taxpayer remains a party to the Treas. Reg. § 1.1275-6 hedge, the hedge is treated as entered into at its fair market value. By contrast, subject to Temp. Treas. Reg. § 1.988-5T(a)(6)(ii)(F), the legging out rules under Treas. Reg. § 1.985-5 treat a taxpayer that legs out of a synthetic debt instrument under § 988 as having disposed of any remaining hedges, and those hedges cannot be part of a qualifying hedging transaction for any period after the leg-out date.

- (d) Treasury and the IRS believe that achieving greater alignment between the hedge integration regimes of §§ 988 and 1275 is beyond the scope of the current project, and unnecessary to achieve the purpose of the temporary regulations. The limited purpose of the new regulation is to clarify the application of the legging out rules under Treas. Reg. § 1.988-5 to a particular fact pattern rather than to undertake a more general revision of those regulations. Continuing to treat the remaining components as integrated, as under the rules of Treas. Reg. § 1.1275-6, would represent a departure from the approach taken in the original Treas. Reg. § 1.988-5 regulations.
- (e) As further support for the recommendation to achieve better alignment between Treas. Reg. §§ 1.988-5 and 1.1275-6, the NYSBA's report also suggested that the provision in Temp. Treas. Reg. § 1.988-5T(a)(6)(ii)(F) would be unnecessary if the regulations were modified to conform to Treas. Reg. § 1.1275-6. Under Temp. Treas. Reg. § 1.988-5T(a)(6)(ii)(F), if a taxpayer legs out of a qualified hedging transaction and realizes a gain with respect to the debt instrument or hedge that is disposed of or otherwise terminated, then the taxpayer is not treated as legging out if during the period beginning 30-days before the leg-out date and ending 30-days after that date the taxpayer enters into another transactions that, taken together with any remaining components of the hedge, hedges at least 50% of the remaining currency flow with respect to the qualifying debt instrument that was part of the qualifying hedge transaction.
- (f) Temp. Treas. Reg. § 1.988-5T(a)(6)(ii)(F) also provides a similar rule where a taxpayer has a qualifying hedge transaction composed of multiple components. In such a case the taxpayer will not be treated as legging out of the qualified hedging transaction if the taxpayer terminates all or a part of one or more components and realizes the net gain with respect to the terminated component, components, or portions thereof, provided that the remaining components of the hedge by themselves hedge at least 50% of the remaining currency flow with respect to the qualifying debt instrument that was part of the qualified hedging transaction.
- (g) The NYSBA's report suggested that this provision of the § 988 hedging rules is unnecessarily complex, as well incomplete because it does not cover situations in which, upon legging out, the taxpayer recognizes a loss on the debt instrument or hedge that is disposed of or otherwise terminated. However, Treasury and the IRS state they are interested in simply clarifying the § 988 hedging rules and focusing on a particular fact pattern. They do not seek to undertake a more general revision of these rules. Accordingly,



they state that modifications to Temp. Treas. Reg. § 1.988-5T(a)(6)(ii)(F) are beyond the scope of this project.

- (h) Finally, the NYSBA’s report also recommended that, even if the final regulations did not adopt the recommendation of aligning the approach taken in Treas. Reg. § 1.1275-6, the § 988 regulations should be modified to provide that, when an issuer of a qualified debt instrument legs out but continues to be the obligor on the qualifying debt instrument, the issuer should be deemed to repurchase and reissue the debt instrument for its then fair market value. The report noted that the temporary regulations indicated that the debt instrument is “treated as sold for its fair market value.” The report said that the sale of a debt instrument has no tax consequences for the issuer of the instrument. Treasury and the IRS agreed that this aspect of the temporary regulations should be modified and, for the sake of consistency, the final regulations adopt the phrase “treated as sold or otherwise terminated by the taxpayer for its fair market value,” which is used in Treas. Reg. § 1.988-5(a)(6)(i)(C) (regarding legging in).

C. International Reorganizations: New IRS Ruling.

- 1. Rev. Rul. 2015-9, I.R.B. 2015-21, revoked Rev. Rul. 78-130, 1978-1 C.B. 114. In the rulings, P, a U.S. company, owns foreign corporations S-1 and S-2. S-1 is an operating company and S-2 is a holding company. S-2 owns foreign subsidiaries, X, Y and Z. In the transaction, P transfers the stock of S-1 to S-2 in exchange for additional S-2 voting stock. In a second pre-arranged step S-1, X, Y and Z transfer their assets to S-2’s newly formed foreign subsidiary, N, in exchange for N common stock. Thereafter, S-1, X, Y and Z liquidate.

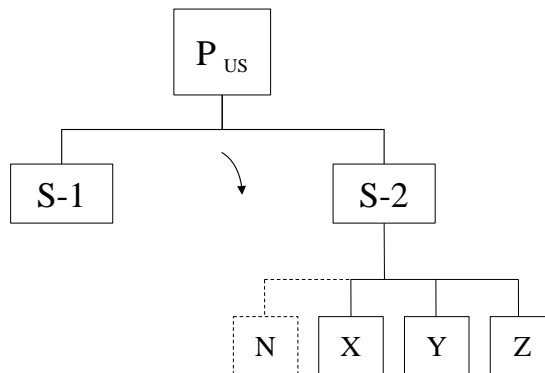

- 2. Rev. Rul. 78-130 treated the S-1 transaction as a triangular C reorganization in which S-1 transferred its assets to N in exchange for the

S-2 stock as the steps were all part of a prearranged, integrated plan. The ruling states that the transaction did not qualify as a D reorganization. Subsequently, however, the definition of “control” for purposes of the D reorganization rules was expanded, and the transaction in the ruling could qualify as a D reorganization of S-1 into N. Thus, the transaction appeared to have become a D reorganization.

3. Later (2009), the Service issued § 368 regulations that could change the transaction back to a triangular C reorganization. If neither S-2 nor N issued additional shares of its stock, Treas. Reg. § 1.368-2(l) would appear in the first instance to require the transaction to qualify as a D reorganization of S-1 directly into N. Treas. Reg. § 1.368-2(l) deems the issuance of stock in certain transactions.
4. A D reorganization requires the issuance of acquiring corporation stock pursuant to § 354. It could be argued that the conveyance of the deemed N share or shares would be deemed to happen anyway, even without the § 368 regulation, under the “meaningless gesture” doctrine. This is discussed in the Treasury Decision’s discussion regarding the adoption of Treas. Reg. § 1.368-2(l). *See* T.D. 9475 (December 17, 2009). The nominal N share thereafter would then be treated as contributed by P to S-2. *See* Treas. Reg. § 1.368-2(l)(2)(i) and (3) Example No. 3.
5. Treas. Reg. § 1.368-2(l), however, contains an important exception. The deemed stock issuance rule will not apply if the transaction can qualify as a triangular reorganization under Treas. Reg. § 1.358-6. *See* Treas. Reg. § 1.368-2(l)(2)(iv). This could include a triangular C.
6. Rev. Rul. 2015-9, however, does something completely different. It characterizes the transaction as a § 351 transfer by P of the S-1 stock to S-2. The subsequent transactions in which S-1, X, Y and Z transfer their assets to N and then liquidate are treated as D reorganizations.
7. The ruling states that a transfer of property may be respected as a § 351 exchange even if it is followed by subsequent transfers of property as part of a prearranged, integrated plan. However, states the ruling, a transfer of property in an exchange otherwise described in § 351 will not qualify as a § 351 exchange if, for example, a different treatment is warranted to reflect the substance of the transaction as a whole.
8. The ruling also states that even though P’s transfer is part of a prearranged, integrated plan involving successive transfers, P’s transfer satisfies the formal requirements of § 351. Further, an analysis of the transaction as a whole does not dictate that P’s transfer be treated other than in accordance with its form in order to reflect the substance of the transaction.

9. The ruling thus ignores the step-transaction doctrine, substituting in its place a vague new rule.
10. The ruling states that P will enter into a GRA with respect to the transfer of P's S-1 stock to S-2. It also states that P will take into account the application of Treas. Reg. § 1.367(b)-4, which may require shareholders that exchange stock of a foreign corporation in certain nonrecognition exchanges to include in income as a deemed dividend the § 1248 amount attributable to the exchanged stock.
11. Rev. Rul. 2015-9 would seem to continue the elective-characterization nature of the transaction so this cannot be the issue that concerned the Service. If N actually issues a share or shares to P it would seem a D characterization should prevail despite the ruling. The property covered by, and described in, the related § 367 gain recognition agreement would vary according to the characterization.
12. An IRS spokesperson, while discussing the new revenue ruling, was quoted as saying with regard to the application of § 367 that "We couldn't find anything that explained the [Service's § 367] thinking [behind Rev. Rul. 78-130]." Thus, international tax issues apparently were involved in the Service's decision to revoke Rev. Rul. 78-130 and recharacterize the transaction. Perhaps the Service was concerned that, in some cases, only a nominal or deemed share in N is all that would be subject to the gain recognition agreement.
13. The alternative characterizations (discussed above) will cause a difference in what is subject to the related GRA.
  - (i) If there's a deemed issuance of N shares to S-1 which are then deemed distributed to P and a deemed contribution of those deemed shares by P to S-2, the GRA should cover the contribution of the deemed shares to S-2
  - (ii) If actual N shares are issued to S-1 and then distributed to P, a GRA would be necessary only if P contributes the shares to S-2
  - (iii) Under Rev. Rul. 2015-9, a GRA is necessary for the S-1 shares contributed to S-2

If § 367 was the Service's concern, it might have been better to change the indirect stock transfer rules in the § 367 regulations than to tinker with the substantive reorganization rules. *See* Treas. Reg. § 1.367(a)-3(d).
14. One would hope the IRS has not so broadened the landscape as to place in doubt long-standing applications of the step-transaction doctrine. The IRS also should explain the standards applicable in analyzing a "transaction as a whole," whatever that means.

15. The Service also issued Rev. Rul. 2015-10, I.R.B. 2015-21, which is similar to Rev. Rul. 2015-9 but describes wholly domestic facts. P owns an LLC treated as a corporation and a first-tier subsidiary (“S-1”). S-1 owns second-tier sub S-2 which in turn owns third-tier sub S-3. P transfers the ownership interests in LLC to S-1 and on down the chain to S-3. The LLC then becomes disregarded under the check-the-box rules. This transaction is treated as two § 351 transfers with the final step treated as a D reorganization.

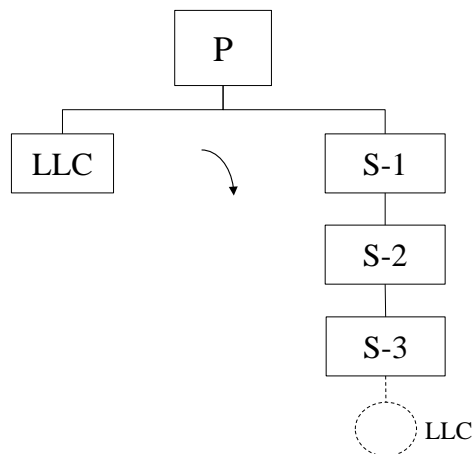

D. All-Cash D Reorgs.

1. In T.D. 9702 (11-10-14), Treasury and the IRS finalized certain temporary regulations issued in 2011 that provided “clarifications” to the nominal share concept in the 2009 final all-cash D reorganization regulations. The final regulations adopt, with nonsubstantive changes, the corresponding proposed regulations. Treas. Reg. § 1.358-2(a)(2)(iii)(B).
2. The concern addressed is that certain taxpayers had taken the position that the shareholder of a transferor corporation that did not own any actual shares of the issuing corporation immediately after the all-cash D reorganization was permitted to designate another person’s share of the issuing corporation’s stock as the share to which the nominal share’s basis could attach.
3. Assume that P owns S-1 and S-2, and that S-1 owns S-3. If S-3 (the transferor) transfers to S-2 all of its assets for cash, S-2 (the issuing corporation) is deemed to issue a nominal share of its stock to S-3. S-3 would then be deemed to distribute the nominal share to S-1 in the transaction.

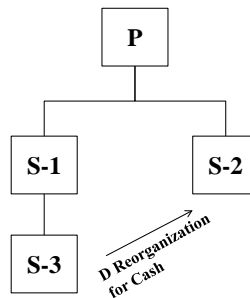

4. Because S-1 received a nominal share of stock in S-2 but did not actually own any S-2 stock, Treas. Reg. § 1.368-2(d)(2) requires that the nominal S-2 share be treated as distributed by S-1 to P to reflect the actual ownership of S-2. P's basis in the nominal is its fair market value under § 301(d).
5. In an attempt to avoid this result, certain taxpayers took the position that S-1 is permitted, after allocating the basis of its S-3 stock to the nominal S-2 share, to designate a share of S-2 stock that is actually held by P as the share to which S-1's basis in the nominal S-2 would attach.
6. The new final regulation "clarifies" that the nominal-share basis-designation rule only applies if an actual shareholder (S-1) of the issuing corporation (S-2) receives the nominal share pursuant to Treas. Reg. § 1.368-2(d). That shareholder must add the nominal share's basis to a share of the issuing corporation's stock that the particular shareholder (S-1) actually owns.
7. Thus, share basis can be lost in an all-cash D reorganization—the basis will disappear completely—unless planning is considered. The planning can be simple: make sure the relevant shareholder (S-1) holds shares in the issuing company (S-2) before the transaction.

E. F Reorganizations.

1. The IRS published final regulations regarding F reorganizations. F reorganizations under § 368(a)(1)(F) involve a "mere change" in the identity, form, or place of organization of one corporation. F reorganizations can be wholly domestic, wholly foreign, or cross border.
2. The new regulations adopt regulations that were proposed in 2004. They also include rules on outbound F reorganizations (domestic transferor corporation and foreign acquiror corporation) by adopting, without substantive change, proposed regulations that were issued in 1990. These regulations, adopted as § 367 regulations, were previously in effect as temporary regulations.

3. Based on prior caselaw, the 2004 proposed regulations would have imposed four requirements for a transaction to qualify as an F reorganization. First, all the stock of the resulting corporation, including stock issued before the transfer, would have had to be issued in respect of stock of the transferor corporation. Second, a change in the ownership of the corporation in the transaction would not have been allowed, except for a change that had no effect other than that of a redemption of less than all of the shares of the corporation. Third, the transferor corporation would have had to completely liquidate in the transaction, although it did not need to legally dissolve. Fourth, the resulting corporation would not have been allowed to hold any property or possess any tax attributes immediately before the transfer, other than a nominal amount of assets to facilitate its organization or to preserve its existence.
4. These requirements would have prevented a transaction that involves the introduction of a new shareholder or new equity capital into the corporation from qualifying as an F reorganization, with one exception: the proposed regulation would have allowed the resulting corporation to issue a nominal amount of stock not in respect of stock of the transferor corporation to facilitate the organization of the resulting corporation. This was intended to facilitate qualification of a transaction as an F reorganization in situations where, for example, the resulting corporation's governing law requires two or more shareholders and the transferor corporation has only one shareholder.
5. The final regulations generally adopt the regulations proposed in 2004, but with certain changes. The preamble states that like the 2004 proposed regulations, the final regulations are based on the premise that it is appropriate to treat the resulting corporation in an F reorganization as the functional equivalent of the transferor corporation and to give its corporate enterprise roughly the same freedom of action as would be accorded a corporation that remains within its original corporate shell.
6. Under the final regulations, *six* requirements apply. Four of the six requirements are generally adopted from the 2004 proposed regulations. The fifth and sixth requirements address comments received with respect to the proposed regulations regarding "overlap transactions," for example, transactions involving the transferor corporation's transfer of its assets to a potential successor corporation other than the resulting corporation in a transaction that could also qualify for nonrecognition treatment under a different provision of the Code.
7. Under the fifth requirement, immediately after the F reorganization, no corporation other than a resulting corporation may hold property that was held by the transferor corporation immediately before the F reorganization if the other corporation would, as a result, succeed to and take into account the items of the transferor corporation described in § 381(c) (corporate

attributes in a reorganization). The sixth requirement is that immediately after the F reorganization, the resulting corporation may not hold property acquired from a corporation other than a transferor corporation if the resulting corporation would, as a result, succeed to and take into account the items of the other corporation described in § 381(c).

8. F Reorganization “in a Bubble.”

- (a) The 2004 proposed regulations also contained an independently important rule: an F reorganization may be a step, or series of steps, before, within, or after other transactions that effect more than a mere change, even if the resulting corporation has only a transitory existence following the mere change. In some cases, an F reorganization sets the stage for later transactions by alleviating non-tax impediments to a transfer of assets. In other cases, prior transactions may tailor the assets and shareholders of the transferor corporation before the commencement of the F reorganization.
- (b) Treasury and the IRS concluded that step transaction principles generally should not apply to recharacterize the F reorganization in such a situation because F reorganizations involve only one corporation and do not resemble sales of assets. This view is consistent with an important previous ruling, Rev. Rul. 96-29, and is included in the final regulation.
- (c) However, the preamble states that notwithstanding this rule, *in a cross-border context*, related events preceding or following an F reorganization may be related to the tax consequences under certain international provisions that apply to F reorganizations. For example, such events may be relevant for purposes of applying certain rules under § 7874 (inversions) and for purposes of determining whether stock of the resulting corporation should be treated as stock of a controlled foreign corporation for purposes of § 367(b). The preamble cites, for example, § 2.03(b)(iv), Example 2 in Notice 2014-52; and Rev. Rul. 83-23, 1983-1 C.B. 82. Notice 2014-52 is the controversial anti-inversion notice issued last fall.
- (d) The final regulations also adopt a provision of the 2004 proposed regulations that the qualification of a reorganization as an F reorganization would not alter the treatment of other related transactions. For example, if an F reorganization is part of a plan that includes a subsequent merger involving the resulting corporation, the qualification of the F reorganization as such will not alter the tax consequences of the subsequent merger.

9. Outbound F Reorganization.

- (a) If a domestic corporation is the transferor corporation and the acquiring corporation is a foreign corporation in an F reorganization, then, under new Treas. Reg. § 1.367-1(e), the taxable year of the transferor corporation will end with the close of the date of the transfer and the taxable year of the acquiring corporation will end with the close of the date on which the transferor's taxable would have ended but for the occurrence of the transfer. Treas. Reg. § 1.367-1(e) is retroactive to 1987.
- (b) Further, under new Treas. Reg. § 367(a)-1(f), in every F reorganization where the transferor corporation is a domestic corporation and the acquiring corporation is a foreign corporation, there is considered to exist:
  - (i) a transfer of assets by the transferor corporation to the acquiring corporation under § 361(a) in exchange for stock (or stock or securities) of the acquiring corporation and the assumption by the acquiring corporation of the transferor corporation's liabilities;
  - (ii) a distribution of stock (or stock or securities) of the acquiring corporation by the transferor corporation to the shareholders (or shareholders and security holders) of the transferor corporation; and
  - (iii) an exchange by the transferor corporation's shareholders (or shareholders and security holders) of their stock (or stock and securities) of the transferor corporation for stock (or stock and securities) of the acquiring corporation under § 354(a).

10. For purposes of this rule, it is immaterial that the applicable foreign or domestic law treats the acquiring corporation as a continuance of the transferor corporation. Treas. Reg. § 1.367(a)-1(f) is retroactive to 1985.

F. E&P.

- 1. Treasury and the IRS finalized regulations under § 312 that clarify the § 312 regulations regarding the allocation of earnings and profits in tax-free transfers from one corporation to another. Regulations under § 381 also were adopted to modify the definition of an acquiring corporation for purposes of § 381 with regard to certain acquisitions of assets.
- 2. Under the proposed § 312 regulations, if the transferee corporation transferred all of the transferor corporation's assets to a controlled subsidiary following the reorganization transfer, then that controlled



subsidiary would succeed to the transferor corporation's earnings and profits.

3. A number of comments were submitted with respect to the proposed § 312 regulations concerning the potential electivity provided to taxpayers regarding which corporation would succeed to earnings and profits in reorganization transactions. Some of these commentators noted the potential international tax-planning opportunities that would be available.
4. Consequently, Treasury and the IRS subsequently proposed § 381 regulations providing that only the direct acquiring corporation will succeed to the earnings and profits. This will be the result even if the transferee corporation ultimately retains none of the assets because they are contributed to a subsidiary corporation. Both sets of proposed regulations were adopted in a manner to achieve this result.
5. Treasury and the IRS stated that this approach produces more appropriate results because it eliminates the potential electivity criticized by certain commentators.

G. Section 871(m): Dividend Equivalents.

1. Treasury and the IRS issued final and temporary regulations that provide guidance under § 871(m) regarding nonresident alien individuals and foreign corporations that hold certain financial products providing for payments that are contingent upon or determined by reference to U.S. source dividend payments. They also provides guidance to withholding agents that are responsible for withholding U.S. tax with respect to a dividend equivalent.
2. Treasury and the IRS issued temporary and proposed regulations under § 871(m) in January 2012. In December 2013, Treasury and the IRS published final regulations. These regulations finalized a portion of the 2012 proposed § 871(m) regulations. Treasury and the IRS also published a withdrawal of the previous notice of proposed rulemaking, a new notice of proposed rulemaking, and a notice of public hearing on the revised proposed § 871(m) regulations.
3. Treasury and the IRS received numerous comments on the 2013 proposed regulations. Most comments agreed that the approach taken in the 2013 proposed regulations, in particular the use of a test based on delta, was a fair and practical way to apply § 871(m) to financial instruments linked to one or more U.S. equity securities. Commenters, however, identified a number of issues with the 2013 proposed regulations. Many of the comments suggested modifications and clarifications to those regulations.
4. The 2013 proposed regulations provided that a dividend equivalent is treated as a dividend from sources within the U.S. for purposes of the

§ 1441 and related withholding provisions. The final regulations retain this general sourcing provision, which, of course, is provided in § 871(m).

5. The 2013 proposed regulations defined a dividend equivalent as (1) any substitute dividend that references a U.S. source dividend made pursuant to its securities lending or sale-repurchase transaction, (2) any payment that references a U.S. source dividend made pursuant to a specified notional principal contract (“NPC”), (3) any payment that references a U.S. source dividend made pursuant to a specified equity-linked instrument (“ELI”), or (4) any other substantially similar payment. The final regulations retain this four-part definition of a dividend equivalent, but provide certain exceptions.
6. The 2012 proposed regulations used a multi-factor test to determine whether an NPC or ELI is a specified contract subject to withholding under § 871(m). The 2013 proposed regulations replaced the multi-factor test with a single-factor test that employs a “delta” threshold to determine whether a transaction is a § 871(m) transaction. Delta refers to the ratio of a change in the fair market value of a contract to a small change in the fair market value of the property referenced by the contract. Delta is widely used by participants in the derivatives markets to measure and manage risk. Under the test in the 2013 proposed regulations, any NPC or ELI that had a delta of 0.70 or greater when the long party acquired the transaction would be a § 871(m) transaction subject to withholding.
7. Treasury and the IRS proposed a delta-based standard after concluding that it would be provide a comparatively simple, administrable, and objective framework that would also minimize potential avoidance of U.S. withholding tax. Many comments were submitted regarding the delta test. Commenters generally agreed that the delta test was both a fair and comprehensive way to implement § 871(m), but provided comments on several aspects of the test.
8. The final regulations adopt a delta threshold of 0.80 or greater. The final regulations also clarify the definition of delta by specifying that delta is calculated with respect to a small change in the fair market value of the property referenced by the contract. The final regulations also provide that the delta of an NPC or ELI is determined only when the instrument is issued. It is not re-tested when the instrument is purchased or otherwise acquired in the secondary market.
9. An instrument is treated as “issued” when it is entered into, purchased, or otherwise acquired at its inception or original issuance, which includes an issuance that results from a deemed exchange pursuant to § 1001. The final regulations also provide a way to simplify the data calculation for contracts that reference multiple underlying securities.

10. The regulations are lengthy and complex, and I will not discuss them further here. They are discussed in excellent reports by Marie Sapirie, “News Analysis: The Novelty of the Substantial Equivalence Test,” and William Davis, “Treasury Official Addresses Dividend Equivalent Issues.”
11. The regulations are generally effective September 18, 2015. To ensure that brokers have adequate time to develop the systems needed to implement the regulations, however, they generally will apply the transactions issued on or after January 1, 2017. In addition, with respect to transactions issued on or after that date, and before January 1, 2017, that are § 871(m) transactions, the regulations also apply to any payment of a dividend equivalent made on or after January 1, 2018. They do not change the applicability date of Treas. Reg. § 1.871-15(d)(1)(i) for specified NPCs described in that section.

## VII. TREATIES.

### A. Senator Paul – Part I.

1. Senator Rand Paul (R-Ky.) stated that he will continue to object to having tax treaties and protocols move to the Senate floor by unanimous consent. He said that he will continue to object to any unanimous consent request, motion, or waiver of any rule because of his concerns that the treaty information-exchange provisions encroach on U.S. taxpayers’ Fourth Amendment privacy rights. The provisions in the treaties in issue are based on the OECD information exchange standard, which the OECD formally amended in 2012 to explicitly permit “nameless” group requests.
2. An aide to Senator Paul said that Paul would be happy to have the treaties advance but that he wants an opportunity to amend the information-exchange provisions to address his privacy concerns.
3. The National Foreign Trade Council and 12 other business groups wrote to Senator Robert Menendez (D-NJ), Chairman of the Senate Foreign Relations Committee, urging support for tax treaties. They state that no U.S. income tax treaty or protocol has been approved by the U.S. Senate in the last 5 years, and that for over 80 years, income tax treaties have played a critical role in fostering U.S. bilateral trade and investment while protecting U.S. businesses from double taxation of the income they earn selling goods and services in foreign markets.
4. Foreign Relations Committee Chair Robert Menendez (D-NJ) stated that the June 19, 2014 hearings further demonstrate the need to ratify these instruments. He said that the U.S. enjoys expanding trade relationships with Spain and Poland, and that American businesses employ many

thousands of people in these countries. Investment from Spain and Poland in the U.S. also continues to grow and to create jobs here.

5. Senator Paul, a member of the committee, did not attend the hearings. Senator Paul has continued to express his objection to any unanimous consent request, motion, or waiver of any rule because of his concerns that the treaty information-exchange provisions encroach on U.S. taxpayers' Fourth Amendment privacy rights. Senator Menendez asked the Treasury representative at the hearings, Bob Stack, Treasury's Deputy Assistant Secretary (International Tax Affairs), to address the information-sharing concerns raised by Senator Paul.
6. Stack said the objection seems to stem from a mistaken belief that the treaty and protocol adopt a new and unacceptably low standard for information exchange that departs from the U.S. policy of exchanging information only in cases involving a suspicion of tax fraud. Stack said that the "may be relevant" or "is foreseeably relevant" standard in the pending treaty instruments' information-exchange provisions reflects the same substantive standard that has been used for decades in U.S. tax treaties. He stated the standard requires that in order to exchange information, one partner has to demonstrate to the other that it is relevant to some tax proceeding going on in the other jurisdiction.
7. Of the 57 in-force U.S. tax treaties, only one -- the 1996 treaty with Switzerland -- does not use the "relevant" standard and instead restricts information-exchange requests to circumstances relating to "tax fraud and the like," Stack stated. He added that when the U.S. government was seeking information from Swiss banks, it was the Swiss government and the Swiss courts that were denying the U.S. access to information about Americans with Swiss bank accounts based on the "tax fraud and the like" standard in the treaty. Stack said that's why the U.S. has been very anxious to have that standard changed in the Swiss treaty and to conform it to the long-standing "relevant" standard in our other treaties.
8. Stack was asked whether people who have foreign bank accounts should be treated any differently from U.S. citizens who have U.S. bank accounts. Stack replied, "Absolutely not." He said the information exchange provisions under discussion put people with foreign bank accounts on equal footing with U.S. citizens who have bank accounts in the U.S. Under the Internal Revenue Code, the IRS has the authority to seek information that may be relevant or material. The pending treaties permit the IRS to request information that is foreseeably relevant. Thus, in a treaty context, stated Stack, this standard and these provisions are critical to ensuring that U.S. taxpayers cannot avoid their legal obligations by simply shifting their accounts overseas and getting better treatment than their U.S.-resident counterparts.

9. A statement in the memorandum of understanding with Spain signed the same day as the protocol to the U.S.-Spain treaty that says the “Contracting states commit to initiate discussions as soon as possible, but no later than six months after the entry into force of the 2013 protocol, regarding the conclusion of an appropriate agreement to avoid double taxation on investments between Puerto Rico and Spain.”
10. Thomas Barthold, the Congressional Joint Committee on Taxation Chief of Staff, said that U.S. tax treaties do not apply to U.S. territories. As a consequence, residents of Puerto Rico who derive income from Spain, and residents from Spain who derive income from Puerto Rico, do not have the benefits of being exempt from source-state taxation on dividends, interest, and royalties that the U.S. provides to residents of the 50 U.S. states.
11. Stack said it appears that Puerto Rico’s main objective is to increase foreign investment in Puerto Rico and to give Spanish investors lower withholding-tax rates on payments from Puerto Rico to Spain. He noted that when Guam had similar concerns, it was able to enact a statute under its domestic law to grant reduced withholding rates if the investor countries had a treaty relationship with the U.S.
12. The National Foreign Trade Council recommended ratification of the treaty with Poland and the protocol with Spain. It strongly urged the Senate committee to reaffirm the United States historic opposition to double taxation by giving its full support as soon as possible to the two pending treaty instruments.
13. Treasury released its Technical Explanation of the Poland-U.S. treaty and the protocol to the treaty with Spain. The Joint Committee on Taxation also published its Explanations of the proposed treaty and protocol, as it normally does in the context of treaty hearings.

B. Senator Paul – Part II.

1. This continues to be an area of frustration for many international tax advisors. The Senate simply is unable to approve income tax treaties.
2. The AICPA, for example, submitted helpful comments in February 2015 urging that these treaties be approved, as did the National Foreign Tax Council a few months ago. The AICPA says that treaties are vital to U.S. economic growth as well as to U.S. trade and tax policy. They benefit the U.S. economy, and play a very important role in promoting U.S. bilateral trade and investment.
3. The stalled treaty with Chile, states the AICPA, would represent a significant inroad into the South American region, as it would be only the U.S.’s second treaty with a South American country.

4. The AICPA states that the stalled treaty with Hungary would close an important loophole since the existing treaty doesn't have a limit on benefits provision. The stalled treaty with Switzerland would specifically protect Americans against indiscriminate searches of information by either country by limiting administrative assistance to individual cases.
5. Both the Luxembourg and Swiss would update existing exchange of information provisions in combating tax evasion.
6. The Senate has not approved any treaties or protocols since 2010. Thus, the AICPA requests prompt consideration of the seven pending, but stalled, treaties.

C. New Competent Authority Procedures.

1. Rev. Proc. 2015-40 contains updated competent authority procedures. The principal differences between the revenue procedure and the proposed version of the revenue procedure published with Notice 2013-78 include:
  - (1) The revenue procedure narrows the scope of requests to which mandatory pre-filing procedures apply to requests involving taxpayer-initiated positions. A competent authority request that does not involve a taxpayer-initiated position does not require mandatory pre-filing, although the pre-filing procedures are optional in such a case.
  - (2) Taxpayers will not be required to expand the scope of a competent authority request to include interrelated issues as a condition of receiving competent authority assistance. Taxpayers may still be required to provide information that will allow the U.S. competent authority to evaluate the appropriateness of the relief sought under the applicable U.S. tax treaty in light of the taxpayer's positions on interrelated issues.
2. An example of an interrelated issue assumes that a competent authority request is made concerning a company's ongoing license of intangible property to a second company in the same controlled group and that the intangible property covered by the license had been sold in an earlier taxable year by the second company (the licensee) to the first company (the licensor). In such a case, the U.S. competent authority may consider the assumptions underlying the valuation of the intangible property when it was previously sold in evaluating the ongoing license.
3. A second example involves a cost sharing agreement. If a competent authority issue presented by the taxpayer involves the valuation of a platform contribution transaction in a cost sharing agreement, the U.S. competent authority also may consider whether the intangible

development costs incurred pursuant to the arrangement were properly shared.

4. The U.S. competent authority may request that the taxpayer amend its request to include interrelated competent authority issues that the U.S. competent authority identifies. The U.S. competent authority also may recommend that the taxpayer file a bilateral or multilateral APA request to cover the competent authority issues and the identified interrelated competent authority issues. As noted above, if the taxpayer declines to amend its competent authority request, the U.S. competent authority will still endeavor to reach a resolution, but will take into account the taxpayer's positions on interrelated issues in determining the extent to which it will provide relief for the competent authority issues in the request.
  - (3) The revenue procedure clarifies that the U.S. competent authority may consult with taxpayers with respect to certain additional issues that may arise in connection with competent authority requests, such as issues relevant to the determination of foreign tax credits and repatriation payments. This is a helpful clarification that is discussed further below.
  - (4) The U.S. competent authority will not condition assistance on the taxpayer's notification of the U.S. competent authority, or on obtaining its concurrence, regarding signing a standard Form 870 with IRS Examination. Similarly, a taxpayer will not be required to obtain the U.S. competent authority's agreement prior to entering into a closing agreement or similar agreement with IRS Examination, but in these cases the assistance provided by the U.S. competent authority will be limited to seeking correlative relief from the foreign competent authority, thus potentially not eliminating double taxation.
5. This is a big improvement over the proposed competent authority procedures. Under the proposed procedures, the U.S. competent authority would not accept an Exam resolution if the U.S. competent authority had not agreed to the terms of the resolution prior to its execution. Tax Executives Institute ("TEI") among others commented adversely with respect to this issue as proposed in Notice 2013-78.
6. Appeals and Competent Authority.
  - (a) Other changes from the proposed version in Notice 2013-78 were made. In general, these changes are very helpful in eliminating some of the surprising harshness of the competent authority procedures as proposed in Notice 2013-78. The major exception: the rules dealing with the interrelationship of competent authority

and Appeals. These rules remain a major problem, and would seem to strip Appeals of its historic and impartial role when an issue might ultimately go to competent authority.

- (b) A taxpayer may request a simultaneous Appeals procedure (“SAP”) review, which is a review of a competent authority issue under the jurisdiction of the U.S. competent authority with the assistance of IRS Appeals. For a competent authority issue that is initially under the jurisdiction of IRS Appeals, that is, a protest was filed, the U.S. competent authority will decline to provide assistance unless the taxpayer, in connection with certain requirements in the revenue procedure, effectively severs the issue from its protest and then timely files a U.S. competent authority request with respect to the issue.
- (c) SAP review is described as an optional aspect of the U.S. competent authority process “whereby IRS Appeals works jointly with the U.S. competent authority and the taxpayer toward the development of the U.S. competent authority’s position on an underlying U.S.-initiated adjustment prior to the U.S. competent authority’s consultations with the foreign competent authority.”
- (d) The revenue procedure states that the procedure is intended to facilitate the U.S. competent authority’s unilateral consideration of a resolution of the competent authority issue before it presents its position to the foreign competent authority. A taxpayer may request SAP review as part of its competent authority request or in a separate written submission filed no later than 60-days after the taxpayer receives notification that the U.S. competent authority has accepted its competent authority request.
- (e) The U.S. competent authority in its sole discretion will decide whether to accept the taxpayer’s request for SAP review after consulting with IRS Appeals and after considering whether SAP review would unduly burden tax administration, including the competent authority process.
- (f) If the U.S. competent authority accepts a request for SAP review, it will notify the taxpayer and coordinate with both the taxpayer and IRS Appeals on process and timeframe. The manner in which SAP review is conducted will be determined by the U.S. competent authority on a case-by-case basis after consulting with IRS Appeals. In general, IRS Appeals will begin SAP review by reviewing the positions previously taken on the competent authority issues by IRS Examination and the taxpayer and consulting with the taxpayer and the U.S. competent authority. IRS Appeals will conduct its review and consultations in



accordance with standard IRS Appeals practices except that the U.S. competent authority will participate in meetings held between IRS Appeals and the taxpayer. IRS Appeals and the U.S. competent authority will consult on whether other exceptions to standard IRS Appeals practices may be appropriate in a given case.

- (g) The U.S. competent authority will consider the points raised in SAP review before deciding upon the position it will present to the foreign competent authority. Any discussion with respect to the positions taken in SAP review, whether written or oral, are not binding on the taxpayer, the U.S. competent authority or IRS Appeals.
- (h) At any point during SAP review, the U.S. competent authority in its sole discretion may terminate the review with regard to one or more competent authority issues after consulting with IRS Appeals. The standard competent authority process will then apply to any issues removed from SAP review.
- (i) The taxpayer also may withdraw its request for SAP review with regard to one or more competent authority issues at any time during the process. The U.S. competent authority, in turn, will decide whether to continue SAP review for any competent authority issues the taxpayer chooses to retain. The standard competent authority process will then apply to any competent authority issues removed from SAP review.
- (j) A taxpayer that initially presents a competent authority issue to IRS Appeals (that is, the taxpayer filed a protest) may still request U.S. competent authority assistance only if it satisfies the following conditions: (1) the taxpayer files its competent authority request no later than 60-days after its opening conference with IRS Appeals; (2) the competent authority request shows that the taxpayer has properly severed the competent authority issue from the issues in the protest that remain under the jurisdiction of IRS Appeals; (3) the taxpayer has not invoked an alternative dispute resolution program under the jurisdiction of IRS Appeals with respect to the competent authority issue; and (4) the taxpayer has not executed with IRS Appeals a Form 870AD, closing agreement, or any other similar agreement containing the competent authority issue.
- (k) If, during the course of reviewing the taxpayer's issues and after the 60-day period described above has begun, the IRS Appeals representative determines that a potential competent authority issue exists that had not been identified by IRS Examination, the deadline for filing the competent authority request under the

provisions discussed above will be 60-days after the date the taxpayer is first notified that a potential competent authority issue exists.

- (l) The U.S. competent authority may accept the competent authority request as to some or all of the severed issues. If the competent authority accepts the request with respect to only particular severed issues, the U.S. competent authority will assume jurisdiction over only those severed issues, and IRS Appeals procedures will continue to apply to the other severed issues. The taxpayer also may request SAP review with respect to the competent authority issues severed from the IRS Appeals protest, and the U.S. competent authority will consider whether to accept the request for SAP review.
- (m) The revenue procedure does not limit the ability of a taxpayer to obtain IRS Appeals review of a competent authority issue set forth in its competent authority request if, with respect to that competent authority issue: (1) the U.S. competent authority rejects the request or terminates the process; (2) the taxpayer withdraws its request for competent authority assistance; (3) the competent authorities do not reach a resolution; or (4) the taxpayer does not accept the terms of the competent authority resolution.
- (n) If, prior to the effective date of the revenue procedure, either: (1) the IRS has issued a 30-day letter notifying the taxpayer of the right to request IRS Appeals consideration of a competent authority issue; or (2) the competent authority issue is before IRS Appeals, the procedures and time frames set forth in Rev. Proc. 2006-54 (the predecessor to Rev. Proc. 2015-40) will apply to the competent authority issue.
- (o) The rules applicable to the interrelationship of competent authority and Appeals as described in Notice 2013-78 were the subject of substantial criticism by commenters. The proposed version of the revenue procedure had a 30-day period to exit Appeals. This is now a 60-day period. TEI stated in its comments that the short deadline would put tremendous pressure on the first Appeals conference and would inevitably restrict the ability of Appeals officers to perform their normal role. The taxpayer will also be under pressure to quickly make tough decisions regarding whether it wishes to continue with the normal Appeals process and therefore forego an opportunity to pursue a later competent authority case or to immediately move to a competent authority case for mutual agreement procedure issues that are involved in the Appeals process. While 60 days is a longer period than 30 days, TEI's comments still stand, in my view.

- (p) TEI also stated that the procedures represent a significant diminution of the role of Appeals and would jeopardize Appeals' independence. As a result, stated TEI, taxpayers would be denied an independent review by Appeals regarding unagreed issues if they wish to seek relief from double taxation in those cases. My observation: this is as true as it was when TEI made its comments.
- (q) Regarding the proposed change, TEI recommended that the role of the U.S. competent authority be advisory and that Appeals remain the primary decision maker regarding issues that are subject to the Appeals proceeding. Obviously, this recommendation was not accepted.

7. Other Highlights.

- (a) The U.S. competent authority is available for informal consultations with taxpayers (including consultations in which the taxpayer chooses to be anonymous) regarding any competent authority issue. These consultations are available even when the issues are not themselves competent authority issues. For example, states the revenue procedure, the taxpayer may consult the U.S. competent authority on foreign tax credit issues, which may cover, when appropriate, considerations surrounding administrative or other steps that might be available to the taxpayer in the foreign jurisdiction.
- (b) This appears to be a very helpful watering down of the strong language used in the proposed revenue procedure. The proposed revenue procedure referred to the steps the taxpayer must take to establish that a foreign tax paid, or to be paid, will qualify as a compulsory payment for foreign tax credit purposes. Commentators, including TEI, were concerned that the language in the proposed revenue procedure would make pursuing this competent authority consultation one of the required steps that the taxpayer must take to establish that amounts paid to a treaty country constitute compulsory payments for foreign tax credit purposes. The "required" steps specified in this competent authority consultation presumably also would need to be taken. The relevant § 901 regulation, however, provides that a remedy is effective and practical only if the cost and risk are reasonable in light of the amount at issue and likelihood of success.
- (c) Most U.S. treaties contain a limitation on benefits ("LOB") article that enumerates objective tests to determine whether a resident of a treaty country is entitled to benefits under the treaty. Most LOB articles also provide that a resident may be granted treaty benefits

at the discretion of the U.S. competent authority if the resident does not qualify for those benefits under the relevant objective test.

- (d) The U.S. competent authority will not issue a determination regarding whether an applicant satisfies an objective LOB test. Also, the U.S. competent authority will not accept a discretionary LOB request unless the applicant, as part of its request, represents that, and explains why, it does not qualify for the requested benefits under the treaty's LOB provision.
- (e) The user fees for requests for discretionary LOB relief were increased from \$27,500 to \$37,000. The increase will be implemented in two steps.
- (f) The U.S. competent authority typically will not exercise its discretion to grant benefits in certain specified cases: (1) the applicant or any of its affiliates is subject to a special tax regime in its country of residence with respect to the class of income for which benefits are sought (such as a regime for interest income that permits a notional interest deduction with respect to equity); (2) no or minimal tax will be imposed on the item in both the country of residence of the applicant and the country of source, taking into account both domestic law and the treaty provision ("double non-taxation"); (3) the applicant bases its request solely on the fact that it is a direct or indirect subsidiary of a publicly-traded company in a third country and the relevant withholding rate provided in the tax treaty between the U.S. and the country of residence of the applicant is not lower than the corresponding withholding rate in the tax treaty between the U.S. and the country of residence of the parent company or any intermediate owner.
- (g) In the section on "Competent Authority Repatriation," which is the section previously referred to as "Application of Rev. Proc. 99-32," the competent authority procedures permit taxpayers to conform their accounts to reflect the primary adjustment. The new competent authority revenue procedure states that "repatriation payments are described generally in Rev. Proc. 99-32..." The previous revenue procedure stated that the competent authority may provide relief consistent with the *principles* of Rev. Proc. 99-32..." It's not clear what this difference means.
- (h) The Competent Authority Repatriation provision also states that the U.S. competent authority has sole discretion to agree or decline a request for Competent Authority Repatriation or a request as to the specific terms of such treatment. "Specific terms" may have been implicit in the prior revenue procedure, but it presumably would involve things such as a § 965 provision. *See BMC v.*

*Commissioner*, 780 F.3d 669 (5<sup>th</sup> Cir. 2015). Concerns such as this were expressed in an *amicus* brief filed in *BMC* by Microsoft and Medtronic.

- (i) There are a number of other provisions in the revenue procedure including coordination with litigation, reasons for denial or termination of assistance, treaty arbitration provisions, filing protective claims with the competent authority, treaty notifications, and the like. The new revenue procedure is effective for competent authority requests filed on or after October 30, 2015.

D. Competent Authority Statistics.

1. The IRS released its annual competent authority statistics for 2014. Part 1 presents statistics concerning cases involving the allocation and attribution of business profits, and Part 2 presents statistics under all other treaty articles.
2. The table showing case resolutions during 2014 for disputes involving the allocation and attribution of business profits is encouraging. In the “U.S.-initiated adjustments” column, 48 cases were resolved. In 28 of them, the total adjustment was withdrawn by the initiating tax authority. Full correlative relief was granted in 7, and partial correlative relief and partial withdrawal (full relief) occurred in 9 cases. Thus, in 44 cases, there was full relief. One case was withdrawn by the taxpayer, and in one case no relief was granted. Partial relief was the result in two cases.
3. In the “foreign-initiated adjustments” column, 85 cases were resolved. The total adjustment was withdrawn by initiating tax authority in 27 cases. Full correlative relief was granted in 17 cases. Partial correlative relief and partial withdrawal (full relief) occurred in 37 cases. Thus, in 81 cases, there was full relief. One case was withdrawn by the taxpayer and in only one case was there no relief. Partial correlative relief resulted in two cases.
4. In the table showing requests received, U.S. initiated adjustment cases were substantially up in 2014 over prior years. Foreign-initiated adjustment cases were on a par with 2013 and both years were significantly higher than previous years.
5. The table that sets forth average processing time also is encouraging. The average processing time for U.S. initiated adjustments was 15 months versus 23 months or higher in the previous 4 years. Average processing time was slightly improved for foreign-initiated adjustments to a 25.3-month period.
6. In Part 2, dealing with statistics arising under all other treaty articles (other than allocation and attribution of business profits), not surprisingly fewer

cases were received and resolved. That is, there were many more cases in the Part 1 category dealing with the allocation and attribution of business profits. In the “U.S.-initiated cases” column, 34 cases were resolved and 30 new cases received. As to “foreign-initiated cases,” 18 cases were resolved and 38 new requests were received.

7. Average processing time for U.S.-initiated Part 2 cases was 14 months and for foreign-initiated cases, 30 months.

E. Starr International: Treaty Issue.

1. A federal district court held in *Starr International Co. v. United States*, \_\_\_ F. Supp. 2d \_\_\_ (D.D.C. 2015), that the IRS’s decision to deny discretionary treaty benefits in the form of a lower dividend withholding tax rate was judicially reviewable, finding that the decision is not committed exclusively to the agency’s discretion. This is an important case of first impression.
2. Starr transferred its insurance business to AIG in the 1970s and became the largest holder of AIG common shares. At that time Maurice Greenberg was the chairman of the board of both companies, and AIG’s CEO. For the next several decades, Starr funded discretionary compensation plans for AIG executives. In 2004, Starr moved its headquarters from Bermuda to Ireland and began to take advantage of the U.S.-Ireland tax treaty, which reduced Starr’s U.S. withholding tax rate on AIG dividends to 15%.
3. The next year, amidst an investigation by New York’s Attorney General, Greenberg stepped down as CEO of AIG, and Starr ceased funding AIG’s executive compensation plan. Starr relocated its headquarters to Switzerland, allegedly to protect its assets from an AIG lawsuit claiming that Starr was contractually obligated to continuing funding the plan. In fact, a lawsuit did arise with AIG unsuccessfully claiming ownership of the AIG shares held by Starr. 648 F. Supp. 2d 546 (S.D.N.Y. 2009).
4. Under the U.S.–Swiss treaty, a Swiss company receiving dividends from a U.S. company is automatically entitled to halve its withholdings under certain enumerated circumstances, such as when the Swiss company does significant business in Switzerland or is listed on a recognized stock exchange. This is the treaty’s Limitation on Benefits article. If a company is not automatically entitled to those benefits under the treaty it “may, nevertheless, be granted the benefits of the Convention if the competent authority of the State in which the income arises so determines after consultation with the competent authority of the other Contracting State.”

5. In 2007, Starr requested benefits under this discretionary relief provision by a letter to the U.S. competent authority. In doing so, Starr acknowledged that it was not entitled to treaty benefits under any of the enumerated, mandatory categories. In March 2010, not having received a response to its letter but wishing to preserve its right to a refund, Starr sent a 2007 tax return form to the IRS contending that it had overpaid \$38 million in taxes. In October 2010, the U.S. competent authority denied Starr's request to apply the treaty to reduce Starr's 2007 withholding tax. Curiously, Starr was later issued a treaty-based refund for its 2008 withholding taxes.
6. Starr filed in court in September 2014, claiming the IRS had erroneously denied its request for benefits under the treaty. Starr contends that the IRS abused its discretion because (1) Starr was not treaty shopping when it relocated to Switzerland, (2) the IRS failed to consult with the Swiss competent authority for denying Starr's request, and (3) the IRS had no legal basis for issuing Starr a 2008 refund while denying its 2007 refund based on the same material facts.
7. The IRS has raised two main defenses to Starr's claims: that the U.S. competent authority's decision is committed to agency discretion by law and, alternatively, that the court lacks jurisdiction under the political-question doctrine.
8. Analysis.
  - (a) Before deciding whether the committed-to-agency-discretion exception to judicial review barred the court from hearing Starr's claim, the court said it needed to decide whether the exception even applied. Starr brought its case under provisions of the United States Code and not the Administrative Procedure Act ("APA"). The question was whether the committed-to-agency-discretion exception is limited to suits brought under the APA.
  - (b) The committed-to-agency-discretion exception is linked closely to language in the APA, which states that agency action is generally reviewable "except to the extent that...it is committed to agency discretion by law." The IRS cited this provision of the APA claiming that denials of the tax benefits in issue are "committed to agency discretion by law."
  - (c) The court held that the exception is not limited to suits brought under the APA and that the IRS may thus attempt to invoke. The APA does explicitly carve out an exception to judicial review for action that is committed to agency discretion by law. Under these principles, "A matter committed to agency discretion is not

reviewable because courts lack judicially manageable standards by which to evaluate it.”

- (d) Other courts have considered the committed-to-agency-discretion exception in the context of tax disputes not brought under the APA. Specifically, courts have applied this exception – and found judicial review unavailable – in interest-abatement suits, in which taxpayers sought reductions in interest on late taxes by arguing that the IRS caused any delays.
- (e) Starr cited *Tax Analysts & Advocates v. Shultz*, 376 F. Supp. 889 (D.D.C. 1974), in arguing that an IRS decision to deny tax-treaty benefits is judicially reviewable. There an interest group challenged an IRS revenue ruling related to gift-tax treatment of contributions to political organizations, and the IRS claimed that its ruling was committed to the sole discretion of the agency unless challenged in a refund suit. Acknowledging that the committed-to-agency-discretion exception is a very narrow exception, the court rejected the IRS’s defense because it cited no law which commits IRS action to IRS discretion.
- (f) *Tax Analysts* thus held that the committed-to-agency-discretion exception to judicial review does not categorically apply to all IRS decisions, but it did not foreclose the possibility that the exception could apply to some IRS decisions.
- (g) Having found that the committed-to-agency-discretion exception to judicial review may be invoked in tax-refund suits, the court next addressed whether the treaty at issue precludes judicial review. Absent an express statutory prohibition on judicial review, courts have been extremely hesitant to find such a bar. The mere fact that a statute grants broad discretion to an agency does not render the agency’s decision completely non-reviewable under the committed-to-agency-discretion exception unless the statutory scheme, taken together with other relevant materials, provides absolutely no guidance on how that discretion is to be exercised.
- (h) Having found that the discretionary provision of the treaty is not categorically non-justiciable, the court turned to its “language, structure and history.” The court stated that the treaty text alone left entirely open what the competent authority may consider when she “so determines” whether to grant or deny the benefits. Such broadly permissive language may indicate an intent to render agency action unreviewable.
- (i) Many statutes, however, afford agencies significant autonomy while remaining subject to judicial review. Permissive language



alone may not be enough to demonstrate that a decision has been committed to agency discretion. Without such clear and convincing evidence, the general presumption favoring judicial review of administrative action is controlling.

- (j) Neither Starr nor the IRS considered the discretion a provision in a vacuum: both looked to the Treasury Department's Technical Explanation of the treaty. The court said that technical explanations serve as an analog to legislative history for treaty ratification, and courts consult these explanations when construing treaty language.
- (k) Here, the Technical Explanation provided that the  

“[discretionary] provision is included in recognition of the fact that, with the increasing scope and diversity of international economic relations, there may be cases where significant participation by the third country residents in an enterprise of a Contracting State is warranted by sound business practice or long-standing business structures and does not necessarily indicate a motive of attempting to derive unintended Convention benefits.”
- (l) In other words, stated the court, the treaty is designed to ensure that legitimate Swiss and U.S. businesses do not pay full taxes in both countries, while also preventing companies from “treaty shopping” by changing their citizenship purely to obtain preferential tax treatment. The Technical Explanation thus clarifies, to a large degree, the applicable legal standard when the Treasury evaluates a claim for benefits under the discretionary provisions. The Technical Explanation, which was transmitted to the Senate before it consented to the treaty, thus put the Senate on notice of how the IRS would endeavor to exercise its authority under the discretionary provision.
- (m) So, too, the testimony offered to the Senate Foreign Relations Committee by the Treasury Department's Deputy Assistant Secretary for International Tax Affairs. He said that, when implementing the discretionary provision, the IRS would seek to determine whether entities “can establish a substantial non-treaty-shopping motive for establishing themselves in their country of residence.
- (n) Moreover, the IRS effectively acknowledged in its formal letter denying Starr's refund for the 2007 tax year that it relies on the standard described in the Technical Explanation to make determinations under the discretionary provision.

- (o) Although the treaty does not expressly preclude judicial review, the discretionary provision may still be nonjusticiable if any standards the court might apply are so broad and vague that judicial review would be “conceptually equivalent to ... no review at all.” While the discretionary provision says that the competent authority “may” grant benefits if she “so determines,” the Technical Explanation elaborates that she “*will* base a determination ... on whether the establishment, acquisition or maintenance of the person seeking benefits under the Convention, or the conduct of such person’s operations, has or had one of its principal purposes the obtaining the benefits under the Convention.”
- (p) The court stated that courts routinely face somewhat amorphous and open-ended standards. The D.C. Circuit has held the phrase “in the interest of justice” provides sufficient guidance to allow at least some minimal judicial review.
- (q) Put simply, the committed-to-agency-discretion exception to judicial review is extremely narrow where, as here, no presumption of unreviewability applies. The Technical Explanation provides meaningful standards that would enable the court to determine whether the IRS abused its discretion in denying treaty benefits. Because this inquiry is not directionless, the court held that denials of tax benefits under the discretionary provision are not committed to the IRS’s unreviewable discretion.
- (r) The IRS also argued that the court may not review the U.S. competent authority’s decision to deny Starr benefits under the treaty because to do so would run afoul of the political-question doctrine. That doctrine, like the committed-to-agency-discretion principle, is a “narrow exception” to the federal courts’ duty to decide cases properly before them.
- (s) The Supreme Court recently explained that a political question exists where there is “a textually demonstrable constitutional commitment of the issue to a coordinate political department; or a lack of judicially discoverable and manageable standards for resolving it.” The court stated that it had already determined that the discretionary provision—read in conjunction with the Technical Explanation—provided a sufficiently manageable standard for judicial review. That being so, the propriety of denying Starr’s request for benefits under the treaty is also not committed to the Executive Branch’s unfettered discretion.
- (t) The IRS argued that judicial review under the discretionary provision’s consultation requirement would impinge on the

Executive Branch’s allegedly exclusive authority to “formulate and implement foreign policy.” The court said that requirement is not presently implicated, because the treaty does not condition the *denial* of treaty benefits on prior consultation with Swiss officials. The relevant treaty official needs “consult with the competent authority of the other contracting state” only when a claimant would be “*granted* the benefits of the convention.”

- (u) The decision to award or deny tax-treaty benefits does not require a policy determinations or diplomatic value judgments. Assessing litigants’ entitlement to relief under federal law is, rather, “a familiar judicial exercise.”
- (v) The case will next proceed to a determination as to whether the U.S. competent authority abused its discretion in denying Starr the requested relief.

F. New U.S. Model treaty.

1. The U.S. Treasury Department released for public comment proposed changes to the U.S. Model Income Tax Treaty. These changes are designed to have an impact on the BEPS project. *See* below. The proposed revisions include language that seeks to address the problem of so-called stateless income, define and prohibit special tax regimes, and tax the foreign parent companies of domestic companies that are trying to invert.
2. Exempt Permanent Establishments.
  - (a) Proposed new Article 1(7), dealing with so-called exempt permanent establishments, deals with the treatment of income in situations where a resident of a contracting state earns income from the other state through a permanent establishment situated outside of the residence state, and the resident is subject to a significantly lower tax rate with respect to the income attributable to the permanent establishment. A Treasury official noted that the proposed exempt permanent establishment provision is a revised version of the so-called “triangular” permanent establishment rule found in a number of recent U.S. treaties’ LOB provisions (Belgium, Denmark, Luxembourg, and Switzerland, for example).
  - (b) As an example, the Technical Explanation describes a resident of the other contracting state that sets up a permanent establishment in a third state that imposes a low or zero rate of tax on the income of the permanent establishment. The income attributable to the permanent establishment is exempt from tax in the other contracting state, either pursuant to an income tax treaty in force

between the other contracting state and the third state where the permanent establishment is located or pursuant to the other contracting state's domestic law. The resident of the other contracting state lends funds into the U.S. through the permanent establishment. The permanent establishment, despite being situated in a third state, is an integral part of the resident of the other contracting state. Therefore, interest received by the resident with respect to loans issued by the permanent establishment, absent the provisions of the new Article 1(7), would be entitled to exemption from U.S. withholding tax under the treaty assuming all other requirements have been satisfied. Thus, the interest income, absent the new provision, would be exempt from U.S. tax, subject to little or no tax in the third state of the permanent establishment, and exempt from tax in the other contracting state.

- (c) New paragraph 7 provides that when an enterprise of a contracting state derives income from the other contracting state that is treated as attributable to a permanent establishment situated outside the contracting state of residence, the tax benefits that would otherwise apply under the other provisions of the convention will not apply to that income if either (a) the profits of that permanent establishment is subject to a combined aggregate effective rate of tax in the first-mentioned contracting state and the state in which the permanent establishment is situated of less than 60% of the general tax rate of the company tax applicable in the first-mentioned contracting state; or (b) the state in which the permanent establishment is situated does not have a comprehensive income tax treaty in force with the contracting state from which the benefits of the convention are being claimed. Any income to which this paragraph applies will be subject to tax under the domestic law of the contracting state from which the benefits are being claimed, notwithstanding any other provision of the convention.
- (d) In a second example, the Technical Explanation describes a resident of the other contracting state that engages in an activity in the United States that does not rise to the level of a trade or business and is therefore not taxed in the United States. The other contracting state, however, treats the activity as a permanent establishment situated outside the United States. U.S. source interest is paid to the resident of the other contracting state, and the other contracting state treats the interest as attributable to the U.S. permanent establishment. If the combined aggregate effective rate of tax on the profits treated as attributable to the permanent establishment, taking into account taxes paid both in the United States and the other contracting state, is less than 60% of the general rate of company tax applicable in the other contracting

state, the provisions of new paragraph 7 would be triggered. Thus, the U.S. source interest income paid to the resident of the other contracting state would be subject to tax in accordance with the domestic law of the United States. The example illustrates how the proposed exempt PE provision would expand the existing “triangular” rule of U.S. treaties, which only applies when the permanent establishment is situated in a third state.

- (e) It is also interesting to consider the effect of the proposed exempt permanent establishments rule if the U.S. were to move to a territorial system. Does Treasury intend that income exempt from U.S. tax under such a system would lose the benefits of the U.S. treaty network?

### 3. Special Tax Regimes.

- (a) The proposal dealing with special tax regimes is intended to avoid instances of “stateless income” or “double non-taxation” whereby a taxpayer uses provisions in the tax treaty, combined with special tax regimes, to pay no or very low tax in the treaty partner country.
- (b) The term “special tax regime” is used in Articles 11 (interest), 12 (royalties) and 21 (other income), each of which denies treaty benefits to items of income if the resident of the other contracting state (the residence state) beneficially owning the interest, royalties or other income, is related to the payor of the income, and benefits from a special tax regime in its residence state with respect to the particular category of income. The rule allows the source state to retain its right to tax an item of income under its domestic law if the resident benefits from the special regime in the resident’s state with respect to a category of income that includes the item and that results in low or no taxation. The term “special tax regime” also is used in Article 22 (limitation on benefits) for the purposes of the so-called “derivative benefits” rule in paragraph 4 of that Article.
- (c) The term “special tax regime” means any legislation, regulation, or administrative practice that provides a preferential effective tax rate to interest, royalties or Article 21 “other income,” including through reductions in the tax rate or tax base. In the case of interest, the term includes any legislation, regulation, or administrative practice, whether or not generally available, that provides notional deductions with respect to equity. For purposes of this definition, an administrative practice includes a ruling practice.
- (d) The Technical Explanation provides an example where a taxpayer obtains a ruling providing that its foreign source interest income

will be subject to a low rate of tax in a residence state and that rate is lower than the rate that generally would apply to foreign source interest income received by residents of that state. The administrative practice under the ruling is a special tax regime.

- (e) A special tax regime does not, however, include any legislation, regulation, or administrative practice that meets at least one of several exceptions. Any legislation, regulation, or administrative practice the application of which does not disproportionately benefit interest, royalties, or Article 21 other income, or any combination thereof, is not a special tax regime. Notwithstanding this statement, notional deductions with respect to equity will always be considered to disproportionately benefit interest. Examples of generally applicable provisions that would not be considered special tax regimes include regimes permitting standard deductions, accelerated depreciation, corporate consolidation, dividends received deductions, loss carryovers and foreign tax credits.
- (f) A second exception with regard to royalties applies for any legislation, regulation or administrative practice that is designed to incentivize, and in fact requires, substantial activities that are not of a mobile nature to be conducted in the resident state. Thus, if the resident state enacts legislation that provides preferential tax treatment for payments received with respect to intellectual property, this legislation is not a special tax regime if the tax benefit provided by the regime is limited (including by a proportionality rule) to income that is attributable to activities of developing the intellectual property that occurred in the residence state. Another example of a regime that is within the exception of this clause is a special economic zone that is intended to stimulate, and in fact requires, investment in manufacturing. In the case of the United States, for example, this exception would apply to §§ 41 and 199, which are available only with respect to research and production activities, respectively, performed in the United States.
- (g) The third exception provides that any legislation, regulation or administrative practice that implements the principles of Article 7 (business profits) or Article 9 (associated enterprises) is not a special tax regime. Thus, if a taxpayer obtains an advance pricing agreement under Article 25 (mutual agreement procedure) or, in the case of the United States, a unilateral APA, the administrative practice under which the APA is obtained is not a special tax regime. However, a special tax regime may include any legislation, regulation or administrative practice, including a ruling practice that is inconsistent with the arm's length principle or the rules for attribution of profits to a permanent establishment

described in the OECD's 2012 report on the attribution of profits to permanent establishments.

- (h) The fourth exception provides that any legislation, regulation, or administrative practice that applies principally to persons that are maintained exclusively for religious, charitable, scientific, artistic, cultural or educational purposes is not a special tax regime.
- (i) The fifth exception provides that any legislation, regulation, or administrative practice that applies principally to regulated entities substantially all the activities of which is to administer or provide pension or retirement benefits is not a special tax regime.
- (j) The sixth exception provides that any legislation, regulation, or administrative practice that facilitates collective investment is not a special tax regime. This exception is intended to apply the collective investment vehicles that are marketed primarily to retail investors, widely-held, hold real estate (immovable property), a diversified portfolio of securities, or a combination thereof, and are subject to investor-protection regulation in the contracting state in which they are organized. This exception applies, for example, to regulated investment companies that are established under § 851.
- (k) This exception also applies, in the case of the United States, to real estate investment trusts that satisfy the requirements of §§ 856 through 859. Although REITs are not required to hold a diversified portfolio of real estate investments, they are designed to facilitate collective investment and are subject to investor-protection regulation.
- (l) The seventh exception provides that, notwithstanding the prior provisions of the subparagraph, the contracting states may agree that any legislation, regulation or administrative practice does not constitute a special tax regime because it does not result in low or no effective rate of taxation.

#### 4. New Limitation on Benefits Clause.

- (a) New Article 22 on limitation on benefits also contains a number of changes. Interestingly, Treasury states that it does not anticipate releasing an advance draft of the technical explanation of this provision since the rules are objective and mechanical in nature and thus are self-explanatory. Among the changes are:
  - i. Including a derivative benefits rule
  - ii. Inserting the base erosion test into the subsidiary of a publicly traded company test

- iii. Requiring application of the base erosion test on a consolidated group basis as well as an individual taxpayer basis
- iv. Eliminating exempt dividend income from “gross income” under the base erosion test
- v. Eliminating from the exceptions to the base erosion tests payments to “good recipients” that benefit from a special tax regime
- vi. Eliminating application of the active trade or business test for pure holding or financing companies, and
- vii. Imposing requirements on intermediary owners when a company seeks to qualify under the derivative benefits test.

5. Subsequent Changes in Law.

- (a) New Article 28 dealing with subsequent changes in the law would give either country the option to turn off the availability of some treaty benefits if the other country enacts legislation (after a treaty is signed) that reduces taxation to a specified level on companies or individuals. The proposed article provides that if the general rate of tax falls below 15% for substantially all income of resident companies, the provisions of the relevant treaty articles may cease to have effect. The availability of those treaty articles may also be turned off if either contracting state provides for taxation of companies on a territorial basis through an exemption for substantially all foreign-source income, including royalties and interest.
- (b) The Technical Explanation to this proposed change states that “neither a gap nor an overlap” is intended between the application of new Article 28 and the definition of “special tax regime” in new Article 3(1)(l) with respect to interest, royalties, and Article 21 other income.

6. Payments by Expatriated Entities.

- (a) A new provision in the dividends, interests, royalties and other income articles would address payments by “expatriated entities.” These categories of income may be taxed in accordance with the domestic laws of the United States for a period of 10 years beginning on the date on which the acquisition of the domestic entity is completed. Thus, there would be full withholding taxes on payments such as dividends and base-stripping payments, including interest and royalties, made by U.S. companies that are



expatriated entities as defined in § 7874. Presumably the term would be defined by reference to the 60% continuity of ownership standard.

7. Finally, while not among the draft treaty provisions that were released by Treasury, Treasury also intends to include in the next U.S. model a new article to resolve disputes between tax authorities through mandatory binding arbitration.

## VIII. INVERSIONS.

### A. Notice 2014-52.

1. In Notice 2014-52, the Treasury Department and the IRS state they intend to issue regulations that will address transactions that are structured to avoid the purposes of §§ 7874 and 367 by (1) for purposes of § 7874, disregarding certain stock of a foreign acquiring corporation that holds a significant amount of passive assets; (2) for purposes of §§ 7874 and 367, disregarding certain non-ordinary course distributions (including transactions such as dividends, redemptions, spinoffs, etc. during a three-year look-back period); and (3) for purposes of § 7874, providing guidance on the treatment of certain transfers of stock of a foreign acquiring corporation (through a spin-off or otherwise) that occur after an acquisition.
2. The Notice also describes regulations that Treasury and the IRS intend to issue that will address certain tax avoidance by (1) preventing the avoidance of § 956 through post-inversion acquisitions by controlled foreign corporations (CFCs) of obligations of (or equity investments in) the new foreign parent corporation or certain foreign affiliates (treating such loans in effect as though they were made to the U.S. shareholder for purposes of § 956); (2) preventing the avoidance of U.S. tax on pre-inversion earnings and profits of CFCs through post-inversion transactions that otherwise would terminate the CFC status of foreign subsidiaries and/or substantially dilute the U.S. shareholders' interest in those earnings and profits (by utilizing § 7701(l)'s multiple-party financing-transaction rules in a novel and questionable manner); and (3) limiting the ability to remove untaxed foreign earnings and profits of CFCs through related-party stock sales subject to § 304.
3. The new Notice has been the subject of much discussion questioning its legal underpinning. Section 7874(c)(4), for example, is used to support certain changes regarding so-called non-ordinary distributions. Under the Notice, these distributions, even those that occurred 3 years before the inversion transaction, "will" be treated as a part of a plan a principal purpose of which is to avoid the purposes of § 7874. The statute says certain transactions can be disregarded "if" they are part of such a plan.

Changing “if” to “will” reminds me of the case, *Utility Air Regulatory Group v. Environmental Protection Agency*, \_\_\_ U.S. \_\_\_ (2014), which held that an administrative “agency may not rewrite clear statutory terms to suite its own sense of how the statute should operate.”

4. Treasury and the IRS also ask for comments regarding earnings stripping through the use of intercompany debt, although no rule was stated to be imminent in this regard. Any future guidance will be prospective only, but to the extent it applies only to inverted groups, it will apply to groups that completed inversions on or after September 22, 2014.
5. The new rules are generally applicable to inversion completed on or after September 22, 2014.
6. The U.S. Chamber of Commerce issued the following statement on the Obama Administration’s announcement on tax inversions:
7. There are three main reasons for a company to change its tax domicile: first, to remove future foreign source income from a secondary level of U.S. taxation, the territorial issue; second, to avoid the highest tax rate in the industrialized world on all income earned abroad; and, third, to access accumulated cash in the former U.S. foreign subsidiary via a series of loans through the new foreign parent.
8. Treasury’s actions today will close off the third option and thus make inversions less profitable—but not unprofitable—for inverting companies that wanted to bring the cash held abroad back to the U.S. Inverting companies will still receive all of the benefits of the first two reasons for inverting. Moreover, if companies want to use the accumulated cash in the former foreign subsidiary, they can still do so. They just must use the proceeds abroad to create income and jobs abroad. In fact, the Administration just assured that deferred income in the once foreign subsidiary will never come back to the U.S. to help create income, jobs, and economic growth here.
9. The Administration’s vain attempt to lock corporations in to an obsolete tax system will only serve to further lock capital out.
10. Rather than piecemeal, onerous actions, the Administration should undertake comprehensive tax reform that lowers rates for all businesses and shifts to an internationally competitive system that welcomes investment and produces the economic growth this country needs.

B. 25% Requirement: Regulations.

1. Treasury and the IRS issued final regulations regarding when an expanded affiliated group will be considered to have substantial business activities in a foreign country. Initially, Treasury and the IRS proposed a 10% safe

harbor based on assets, employees, and revenue. Later, Treasury and the IRS eliminated the 10% safe harbor and transmuted the substantial business activities requirement into a facts and circumstances test. Temporary and proposed regulations were issued in 2006, but later withdrawn. Temporary and proposed regulations were issued in 2009, but later withdrawn.

2. Temporary and proposed regulations were again issued in 2012. These regulations changed everything by implementing a highly controversial 25% minimum-threshold requirement with respect to assets, employees and revenue to satisfy the substantial business presence test. These are the proposed regulations that were adopted as final. A public hearing was not requested or held, although comments were received. Most comments were rejected, however.
3. Under § 7874(a)(2)(B), a foreign corporation is generally treated as a surrogate foreign corporation if pursuant to a plan (or a series of related transactions): (1) the foreign corporation completes after March 4, 2003 the direct or indirect acquisition of substantially all the properties held directly or indirectly by a domestic corporation (“acquisition”); (2) after the acquisition, at least 60% of the stock by vote or value of the foreign corporation is held by former shareholders of the domestic corporation by reason of holding stock in the domestic corporation; and (3) after the acquisition, the expanded affiliated group that includes the foreign corporation (“EAG”) does not have substantial business activities in the foreign country in which, or under the laws of which, the foreign corporation is created or organized (“relevant foreign country”), when compared to the total business activities of the EAG. Similar provisions apply if a foreign corporation acquires substantially all the properties constituting a trade or business of a domestic partnership.
4. Under the bright-line rule a company can satisfy the substantial business activity provision (and avoid the anti-inversion rules) only if at least 25% of the EAG’s employees, assets and income are located or derived in the relevant foreign country.
5. Many commenters criticized this approach on the grounds that there is insufficient support for this bright-line rule in the legislative history. Some commenters recommended reverting to a general facts and circumstances test, along with a safe harbor, given the difficulty of formulating a bright-line rule that produces appropriate results in all circumstances. Some commenters suggested that the failure to satisfy the bright-line rule could establish a rebuttable presumption that an EAG does not have substantial business activities in the relevant foreign country.
6. Treasury and the IRS rejected these comments and concluded that the bright-line rule is consistent with § 7874 and its underlying policies. In

addition, states the preamble, the bright-line rule has proven more administrable than a facts-and-circumstances test that has the benefit of providing certainty in applying § 7874 to particular transactions.

7. Most comments were rejected, and the proposed regulations were adopted with only minor changes. They are effective with respect to acquisitions completed on or after June 3, 2015, although the 2012 temporary regulations apply to acquisitions completed after June 7, 2012. Thus, the change in date is not significant.

## IX. ADMINISTRATION'S 2016 BUDGET.

A. The so-called "Green Book" describing the Administration's Fiscal Year 2016 tax proposals was published in February 2015. It is entitled "General Explanations of the Administration's Fiscal Year 2016 Revenue Proposals." Some of the international proposals are different from those proposed in prior years, and some international "centerpiece" proposals from prior years do not appear in the FY 2016 Budget. The international centerpiece of the 2016 Budget is a 19% minimum tax on foreign income and a 14% one-time tax on previously untaxed foreign income. The international tax proposals are discussed below.

### B. 19-Percent Minimum Tax on Foreign Income.

1. The Administration proposes to supplement the existing Subpart F regime with a per-country minimum tax on the foreign earnings of entities taxed as domestic C corporations (U.S. corporations) and their controlled foreign corporation subsidiaries ("CFCs"). The minimum tax would apply to a U.S. corporation that is a U.S. shareholder of a CFC or that has foreign earnings from a branch or from the performance of services abroad. Under the proposal, the foreign earnings of a CFC or a branch or from the performance of services would be subject to current U.S. tax at a rate of 19% less 85% of the per-country foreign effective tax rate (the residual minimum tax rate).
2. The foreign effective tax rate would be computed on an aggregate basis with respect to all foreign earnings and the associated foreign taxes assigned to a country for the 60-month period that ends on the date on which the domestic corporation's current taxable year ends, or in the case of CFC earnings, that ends on the date on which the CFC's current taxable year ends. For this purpose, foreign taxes taken into account are those taxes that, absent the proposal, would be eligible to be claimed as a foreign tax credit during the 60-month period. Subject to certain rules applicable to hybrid entities, the foreign earnings taken into account for the 60-month period would be determined under U.S. tax principles but would include disregarded payments deductible elsewhere, such as disregarded intra-CFC interest or royalties, and would exclude dividends from related parties.

3. The country to which the foreign earnings and associated foreign taxes are assigned would be based on tax residence under foreign law. For example, if a CFC is incorporated in country X but a tax resident of country Y under both the country X and country Y place of management tests for tax residence, the CFC's earnings and associated foreign taxes would be assigned to country Y for purposes of computing the minimum tax.
4. If instead country Y used a place of incorporation test such that the CFC is "stateless" and is not subject to foreign tax anywhere, the CFC's earnings would be subject to the minimum tax at the full 19% rate. Earnings and taxes of a particular CFC may be allocated to multiple countries if it has earnings subject to tax in different countries.
5. Where the same earnings of the CFC are subject to tax in multiple countries, the earnings and all of the foreign taxes associated with those earnings would be assigned for the highest-tax country. For example, if a CFC incorporated in high-tax country Z has a permanent establishment in low-tax country Q and both country Z and country Q tax the earnings of the permanent establishment, the earnings and both the country Z taxes and the country Q taxes associated with those earnings would be assigned to country Z.
6. The minimum tax for a particular country would be computed by multiplying the applicable residual minimum tax rate by the minimum tax base for that country. A U.S. corporation's tentative minimum tax base with respect to a country for a taxable year would be the total amount of foreign earnings for the taxable year assigned to that country for purposes of determining the effective tax rate for the country.
7. The tentative minimum tax base would be reduced by an allowance for corporate equity ("ACE"). The ACE allowance would provide a risk-free return on equity invested in active assets, which generally would include assets that do not generate foreign personal holding company income (determined without regard to both the look-through rule of § 954(c)(6) and any election to disregard an entity as separate from its owner). Thus, the ACE allowance is intended to exempt from the minimum tax a return on the actual activities undertaken in a foreign country.<sup>3</sup>
8. In assigning earnings to countries, both for purposes of determining the foreign effective tax rate as well as for determining the tentative minimum tax base for a particular year, rules would be implemented to restrict the use of hybrid arrangements to shift earnings from a low-tax country to a

---

<sup>3</sup> In concept, this is similar to the Administration's prior years budgets' "tax currently excess returns associated with transfers of intangibles offshore." A small minimum amount was exempted, and the majority of the income was subject to immediate U.S. tax. Here, of course, *all* CFCs' (and branches') income would be taxed, and the tax would apply regardless of whether there was an intangible property transfer.

high-tax country for U.S. tax purposes without triggering tax in the high-tax country. For example, no deduction would be recognized for a payment from a low-tax country to a high-tax country that would be treated as a dividend eligible for a participation exemption in the high-tax country. In addition, the earnings assigned to a low-tax country would be increased for a dividend payment from a high-tax country that is treated as deductible in the high-tax country.

9. The minimum tax would be imposed on current foreign earnings regardless of whether they are repatriated to the U.S., and all foreign earnings could be repatriated without further U.S. tax. Thus, under the proposal, U.S. tax would be imposed on the CFC's earnings either immediately (either under Subpart F or the minimum tax) or not at all (if the income was subject to sufficient foreign tax or was exempt pursuant to the ACE allowance).
10. Subpart F generally would continue to require a U.S. shareholder of a CFC to include in its gross income on a current basis, at the full U.S. rate (with foreign tax credits available as provided under current law), the shareholder's share of the CFC's Subpart F income, but the Subpart F high-tax exception would be mandatory for U.S. shareholders that are U.S. corporations.
11. No U.S. tax would be imposed on the sale by a U.S. shareholder of stock of a CFC to the extent any gain reflects the undistributed earnings of the CFC which generally would already have been subject to tax under the minimum tax, Subpart F, or the 14-percent one-time tax under the Administration's separate one-time tax proposal. In addition, however, to avoid creating a bias that would affect a U.S. shareholder's decision whether to sell CFC stock or continue to own it (and therefore continue to be subject to U.S. taxation on the CFC's earnings under the minimum tax and Subpart F), any stock gain that is attributable to unrealized (and therefore untaxed) gain in the CFC's assets would be subject to U.S. tax in the same manner as would apply to the future earnings from those assets. Accordingly, stock gain would be subject to the minimum tax or to the tax at the full U.S. rate to the extent it reflects unrealized appreciation in assets that would generate earnings subject to the minimum tax or Subpart F.
12. Foreign-source royalty and interest income payments received by U.S. corporations would continue to be taxed at the full U.S. statutory rate but could not be shielded by excess foreign tax credits associated with dividends from high-tax CFCs because the earnings of high-tax CFCs would be exempt from U.S. tax. A foreign branch of a U.S. corporation would be treated like a CFC. Accordingly, to the extent the foreign branch used intangibles of its owner, the branch would be treated as

making royalty payments to its owner that are recognized for U.S. tax purposes.

13. Interest expense incurred by a U.S. corporation that is allocated and apportioned to the foreign earnings on which the minimum tax is paid would be deductible at the residual minimum tax rate applicable to those earnings. No deduction would be permitted for interest expense allocated and apportioned to foreign earnings for which no U.S. income tax is paid.
14. Rules regarding CFC investments in U.S. property and previously taxed earnings would be repealed for U.S. shareholders that are U.S. corporations.
15. The IRS would be granted authority to issue regulations to carry out the purposes of the minimum tax, including regulations addressing the taxation of undistributed earnings when a U.S. corporation owns an interest in a foreign corporation that has changed in status as a CFC or a non-CFC, and regulations to prevent the avoidance of the purposes of the minimum tax through outbound transfers of built-in-gain assets or CFC stock.

C. 14-Percent One-Time Tax on Previously Untaxed Foreign Income.

1. In connection with the transition to the minimum tax, this proposal would impose a one-time 14-percent tax on earnings accumulated in CFCs and not previously subject to U.S. tax. A credit would be allowed for the amount of foreign taxes associated with the earnings multiplied by the ratio of the one-time tax rate to the minimum U.S. corporate tax rate for 2015. The accumulated income subject to the one-time tax could then be repatriated without any further U.S. tax. Revenue generated by this proposal would be used for new spending associated with the Administration's surface transportation reauthorization proposal and shortfalls between revenue and surface transportation spending that exists under current law for the proposal period.
2. The proposal would be effective on the date of enactment and would apply to earnings accumulated for taxable years beginning before January 1, 2016. The tax would be payable ratably over five years.

D. Intangible Property Transfers.

1. Similar to last year's proposal, this proposal would provide that the definition of intangible property under § 936(h)(3)(B) (and therefore for purposes of §§ 367 and 482) also includes workforce-in-place, goodwill and going concern value, and any other item owned or controlled by a taxpayer that is not a tangible or financial asset and that has substantial value independent of the services of any individual.

2. Also similar to last year's budget, the Green Book states that the proposal "would provide" rather than using the language that was used in budget years prior to last year, "would clarify" current law. This is good, as the proposal indeed would be a change in the law, not a clarification of current law.
3. However, similar to last year's proposal, it adds "any other item owned or controlled by a taxpayer that is not a tangible or financial asset that has substantial value independent of the services of any individual." This would make the definition of intangibles extremely broad, and likely would create significant uncertainty for years to come. It's bad enough that goodwill and going concern value would be intangible assets for purposes of § 482 (transfer pricing, etc.), but this open-ended category would be even worse. How would these "assets" fit within § 482's arm's length requirement?
4. Similar to the Administration's proposals in prior years, the proposal also would clarify that where multiple intangible properties are transferred, or where intangible property is transferred with other property or services, the IRS may value the properties or services on an aggregate basis where it achieves a more reliable result. Further, the proposal would "clarify" that the IRS may value intangible property taking into consideration the prices or profits that the controlled taxpayer could have realized by choosing a realistic alternative to the controlled transaction undertaken.

E. Restrict Deductions for Excessive Interest of Members of Financial Reporting Groups.

1. Similar to last year's budget proposal, this proposal generally would apply to a U.S. entity that is a member of a foreign-parented multinational group that prepares consolidated financial statements ("financial reporting group") in accordance with U.S. generally accepted accounting principles ("GAAP"), international financial reporting standards ("IFRS"), or any other method authorized by the IRS under regulations.
2. Under the proposal a U.S. member's deduction for interest expense generally would be limited if the member has net interest expense for tax purposes and the member's net interest expense for financial reporting purposes (computed on a separate company basis) exceeds the member's proportionate share of the net interest expense reported on the financial reporting group's consolidated financial statements (excess financial statement net interest expense).
3. A member's proportionate share of the financial reporting group's net interest expense would be determined based on the member's proportionate share of the group's earnings (computing by adding back net interest expense, taxes, depreciation, and amortization) reflected on the



group's financial statements. When a member has excess financial statement net interest expense, the member will have excess net interest expense for tax purposes for which a deduction will be disallowed in the same proportion that the member's net interest expense for financial reporting purposes is excess financial statement net interest expense.

4. Alternatively, if a member's net interest expense for financial reporting purposes is less than the member's proportionate share of the net interest expense reported on the group's consolidated financial statements, the excess limitation would be converted into a proportionate amount of excess limitation for tax purposes and carried forward.
5. Also similar to last year's budget, a member fails to substantiate the member's proportionate share of the group's net interest expense, or a member so elects, the member's interest expense will be limited to the member's interest income plus 10% of the member's adjusted taxable income (as defined under § 163(j)). Regardless of whether a taxpayer computes its interest limitation under the proportionate share approach or using the 10% alternative, disallowed interest would be carried forward indefinitely and any excess limitation for a tax year would be carried forward to the three subsequent tax years.
6. A member of a financial reporting group that is subject to the proposal would be exempt from the application of § 163(j).
7. The proposal would not apply to financial services entities, and these entities would be excluded from the financial reporting group for purposes of applying the proposal to other members of the financial reporting group. The proposal also would not apply to financial reporting groups that would otherwise report less than \$5 million of net interest expense, in the aggregate, on one or more U.S. income tax returns for a taxable year. Entities that are exempt from the proposal would remain subject to § 163(j).

F. Other International Repeat Proposals.

1. The Administration's budget would disallow the deduction for excess non-taxed reinsurance premiums paid to affiliates, modify the tax rules for dual capacity taxpayers, tax gain from the sale of a partnership interest on look-through basis, modify § 338(h)(16) and 902 to limit credits when non-deductible taxation exists, restrict the use of hybrid arrangements that create stateless income, and limit the ability of domestic entities to expatriate. Since these are repeat proposals, I will discuss only three of them.
2. The *hybrid arrangements proposal* would deny deductions for interest and royalty payments made to related persons under certain circumstances

involving a hybrid arrangement, including if either (1) as a result of the hybrid arrangement, there is not corresponding inclusion to the recipient in a foreign jurisdiction, or (2) a hybrid arrangement would permit the taxpayer to claim an additional deduction for the same payment in another jurisdiction.

3. The Green Book talks about the “proliferation” of tax avoidance techniques involving a variety of cross-border hybrid arrangements, such as hybrid entities, hybrid instruments, and hybrid transfers such as a sale-repurchase, or “repo” transaction, in which the parties take inconsistent positions regarding the ownership of the same property. The Green Book also discusses the use of reverse hybrid entities, which involves an entity treated as a corporation for U.S. tax purposes, but as fiscally transparent under the laws of a foreign jurisdiction.
4. Under the hybrid proposal, §§ 954(c)(3) and 954(c)(6) (look-through rules) also would be modified so as not to apply to payments made to a foreign reverse hybrid owned directly by one or more U.S. persons when the amounts are received from foreign related persons that claim a deduction for foreign tax purposes with respect to the payment.
5. The § 338(h)(16) *proposal* would extend the application of that provision to covered asset acquisitions within the meaning of § 901(m). The IRS would be granted authority to issue regulations as necessary to carry out the purposes of the proposal. This would create a curious state of affairs since Treasury and the IRS have not written regulations under either § 338(h)(16) or § 901(m), and now would be asked to write regulations on the interrelation of the two provisions.
6. The § 338(h)(16) proposal also includes a proposal not obvious from the heading of that proposal. It would, as was proposed last year, remove foreign taxes from a § 902 corporation’s foreign tax pool when earnings are eliminated. Thus, foreign taxes paid by a foreign corporation would be reduced in the event of a transaction that results in the reduction, allocation, or elimination of a foreign corporation’s earnings and profits other than a reduction by reason of a dividend or § 381 transaction. The amount of foreign taxes that would be reduced in the transaction would equal the amount of foreign taxes associated with those earnings and profits.
7. The *anti-inversion proposal* would reduce the 80% test in § 7874 to a 50-percent test, and eliminate the 60% test. The proposal, similar to the one made last year, also would add a special rule whereby, regardless of the level of shareholder continuity (it would not require any shareholder continuity), an inversion transaction would occur if (1) immediately prior to the acquisition, the fair market value of the stock of the domestic entity is greater than the fair market value of the stock of the foreign acquiring

corporation, (2) the expanded affiliated group is primarily managed and controlled in the U.S. and (3) the expanded affiliated group does not conduct substantial business activities in a country in which the foreign acquiring corporation is created or organized.

8. The budget's proposed anti-inversion "special rule" requires that immediately prior to the acquisition the fair market value of the stock of the domestic entity be greater than the fair market value of the stock of the foreign acquiring corporation. This is a helpful modification vis-à-vis the prior year's proposal.
9. Finally, the budget also repeats the prior years' proposals to provide tax incentives for locating jobs and business activity in the U.S. and to deny tax deductions for shipping jobs overseas.

G. Close Loopholes under Subpart F.

1. The "Close Loopholes under Subpart F" provision consists of four separate proposals. Similar to last year, new categories of Subpart F income are proposed for digital goods or services and for manufacturing services arrangements. These are similar to last year's proposals and I will not discuss them here.
2. The budget also proposes to modify certain thresholds for applying Subpart F. The 30-day grace period before a Subpart F inclusion (dealing with CFC status) would be eliminated, and the proposal would amend the ownership attribution rules of § 958(b) so that certain stock of a foreign corporation owned by a foreign person would be attributed to a U.S. person for purposes of determining whether the related U.S. person is a United States shareholder of that foreign corporation and, therefore, whether the foreign corporation is a CFC.
3. As to the § 958(b) proposal, the pro rata share of the CFC's Subpart F income that a U.S. shareholder is required to include in gross income would continue to be determined based on direct and indirect ownership of the CFC, without application of the ownership attribution rules of § 958(b).
4. The § 958(b) change targets a U.S.-parented group that is acquired by a foreign corporation. The new foreign parent may acquire a sufficient amount of stock in one or more foreign subsidiaries of the former U.S.-parented group to cause the foreign subsidiaries to cease to be CFCs. This would prevent that planning opportunity.

H. Other International Proposals. The Administration proposes to repeal the delay in implementation of worldwide interest allocation, extend the exception under Subpart F for active financing income, and extend the look-through treatment of

payments between related CFCs. These are proposed because of the 19% minimum tax on foreign income.

I. Prior Years' International Proposals Not Included.

1. The budget does not include significant provisions proposed in prior years, namely, deferred deduction of interest expense related to deferred income of foreign subsidiaries, determine the foreign tax credit on a worldwide pooling basis, and tax currently excess returns associated with transfers of intangibles offshore. These three provisions were seemingly a centerpiece of the Administration's prior years' international budget proposals.
2. Undoubtedly, they were not included in this year's budget because of the 19% minimum tax on foreign income. The disallowed interest-expense provision, for example, is included, in modified form, in the proposal for the 19% tax on foreign earnings.

J. Tax Corporate Distributions as Dividends.

1. The "tax corporate distributions as dividends" budget category contains four proposals. They're not targeted solely at international operations and transactions, but can be important internationally. Three of these proposals repeat prior years' proposals: (1) prevent elimination of earnings and profits through distributions of stock with basis attributable to dividend equivalent redemptions; (2) prevent use of leveraged distributions from related foreign corporations to avoid dividend treatment; and (3) repeal the gain limitation for dividends in reorganization exchanges (§ 356). We have discussed these provisions in an international context in the past.
2. The first of the three repeat "tax corporate distributions as dividends" proposals is best understood by considering the discussion in last year's Green Book. That Green Book stated there has been a proliferation of transactions in which corporations distribute stock in subsidiaries having artificially high bases but minimal value in an effort to reduce earnings and profits prior to making large distributions to shareholders in the subsequent taxable year.
3. Assume, for example, stated that Green Book, a parent [or first-tier foreign subsidiary when applied internationally] corporation that owns all of the common stock and preferred stock of a subsidiary corporation. The preferred stock has a value of \$10M, but a basis of \$1B because of previous dividend-equivalent redemptions in which the parent [or first-tier foreign company] received \$990M in cash. Under current law, if an actual or deemed redemption of stock is treated as equivalent to a dividend by a shareholder, the shareholder's basis in any remaining stock of the corporation is increased by the shareholder's basis in the redeemed stock.

Assume also that the parent company [or first-tier foreign company] also has \$1B of earnings and profits.

4. If the parent [or first-tier foreign company] distributes its \$10M of subsidiary preferred stock to its shareholders, it would permanently eliminate any earnings and profits equal to the adjusted basis of the distributed stock (\$1B) even though the parent has not suffered any economic loss or experienced a commensurate reduction in its dividend-paying capacity. Then in the following year, the parent [or first-tier foreign company] could distribute its cash of \$990M to its shareholders and avoid dividend treatment.
5. Last year's Green Book stated that a reduction of a corporation's earnings and profits as a result of the distribution of high-basis stock in a taxable year in which the corporation has not suffered any economic loss, and thus no diminution of its dividend-paying capacity, is not consistent with the role of earnings and profits to measure dividend-paying capacity and inappropriately avoids dividend treatment to the corporation's shareholders.
6. It further stated that in cross-border transactions, the earnings and profits adjustment rules can permit U.S. shareholders to repatriate previously-untaxed earnings and profits of foreign subsidiaries with minimal U.S. tax consequences. According to that Green Book, this is inconsistent with the principle that previously untaxed earnings and profits of a foreign subsidiary should be subject to U.S. tax upon repatriation.
7. The proposal would amend the general earnings and profits adjustment rules applicable to distributions of stock in another company. Under the proposal, a corporation's distribution of stock of another corporation would reduce the distributing corporation's earnings and profits in any tax year by the greater of the stock's fair market value or the corporation's basis in the stock. For this purpose, the distributing corporation's basis in the distributing stock would be determined without regard to any adjustments as a result of actual or deemed dividend-equivalent redemptions by the corporation whose stock is distributed and without regard to any series of distributions or transactions undertaken with the view to create and distribute high-basis stock of any corporation. The IRS would be granted regulatory authority necessary or appropriate to carry out the proposal.
8. Last year's Green Book also described the second of the three repeat "tax corporate distribution as dividends" proposals. It stated that under current law, the determination of whether a corporate distribution is a dividend effectively permits the earnings and profits of one corporation to be repatriated without being characterized as a dividend by having the corporation fund the distribution by a second, related corporation that does

not have earnings and profits, but in which the distributee shareholder has sufficient tax basis to characterize the distribution (in whole or substantial part) as a return of stock basis under the ordering rules of § 301.

9. Last year's proposal provided that to the extent a foreign corporation (the "funding corporation") funds a second, related foreign corporation (the "foreign distributing corporation") with a principal purpose of avoiding dividend treatment on distributions to a U.S. shareholder, the U.S. shareholder's basis in the stock of the distributing corporation will not be taken into account for the purpose of determining the treatment of the distribution under § 301. For this purpose, the funding corporation and the foreign distributing corporation would be related if they are members of a control group within the meaning of § 1563(a), but replacing the reference to "at least 80 percent" with "more than 50 percent." Funding transactions to which the proposal would apply include capital contributions, loans, or distributions to the foreign distributing corporation, whether the funding transaction occurs before or after the distribution.
10. The 2016 budget proposal is slightly different from last year's proposal in that the amount would simply be treated as a dividend from the funding corporation, instead of ignoring the distributing company's stock basis.
11. I'll skip over the proposed § 356 change, as it has been discussed before. It's been in a number of the Administration's budget proposals.
12. The fourth 2016 budget proposal in the "tax corporate distributions as dividends" category would treat hook stock purchased by a subsidiary as giving rise to a deemed distribution. The proposal would disregard a subsidiary's purchase of hook stock for property so that the property used to purchase the hook-stock would give rise to a deemed distribution from the purchasing subsidiary (through any intervening entities) to the issuing corporation. The hook-stock would be treated as being contributed by the issuer (through any intervening entities) to the subsidiary.
13. The hook-stock proposal would grant the IRS authority to prescribe regulations to treat purchases of interests in shareholder entities other than corporations in a similar manner and provide rules related to hook stock within a consolidated group.

K. Other Proposals.

1. A proposal to "limit the importation of losses under the related-party loss limitation rules," a repeat from prior years' budgets, addresses § 267. Section 267(d) shifts the benefit of loss from the transferor to the transferee in related-party loss sales. Losses thus can be imported where gain or loss with respect to the property is not subject to federal income tax in the hands of the transferor immediately before the transfer but any

gain or loss with respect to the property is subject to federal income tax in the hands of the transferee immediately after the transfer.

2. The proposal would amend § 267 to provide that the principles of § 267(d) do not apply to the extent gain or loss with respect to the property is not subject to federal income tax in the hands of transferor immediately before the transfer but any gain or loss with respect to the property is subject to federal income tax in the hands of the transferee immediately after the transfer.
3. Another proposal would eliminate the § 708 “technical termination” rule. Section 708(b)(1)(B) provides that if within a 12-month period, there is a sale or exchange of 50% or more of the total interest in a partnership capital and profits, the partnership is treated as having terminated for U.S. federal tax purposes. This is referred to as a “technical termination” because the termination occurs solely for tax purposes even though the entity continues to exist for local law purposes and the business of the partnership continues.
4. Even though the business of the partnership continues in the same legal form, several unanticipated consequences can occur as a result of the technical termination, including, among other things, the restart of the § 168 depreciation lives, the close of the partnership’s tax year, and the loss of all partnership level elections. Accordingly, states the Green Book, this rule currently serves as a trap for the unwary taxpayer or as an alternative planning tool for the savvy taxpayer. This, too, is a repeat from prior years’ budgets.
5. Another repeat provision would provide for the reciprocal reporting of information in connection with the implementation of the Foreign Account Tax Compliance Act (“FATCA”). The proposal would require certain financial institutions to report the account balances for all financial accounts maintained at a U.S. office and held by foreign persons.
6. In another proposal, the nonqualified preferred stock (“NQPS”) designation in § 351 would be repealed. Congress added the provision in 1997. NQPS is also treated as boot in certain shareholder exchanges pursuant to a corporate reorganization. Since NQPS treated like debt for certain limited purposes, but otherwise generally is treated as stock, it has a hybrid nature which, according to the Green Book, has transformed it into a staple of affirmative corporate tax planning. Its issuance often occurs in loss-recognition planning, where NQPS is treated as debt-like boot, or to avoid the application of a provision that treats a related-party stock sale as a dividend. Thus, for the unwary, the designation prevents the proverbial trap for the unwary, while for the well advised, the issuance of NQPS often arises in transactions that are inconsistent with the original purpose of the provision.

7. The budget would also provide relief for certain “accidental” dual citizens. Individuals who became citizens of both the U.S. and another country at birth may have had minimal contact with the U.S. and may not learn until later in life that they are U.S. citizens. In addition, these individuals may be citizens of countries where dual citizenship is illegal. Many of these individuals would like to relinquish their U.S. citizenship in accordance with established State Department procedures, but doing so would require them to pay significant U.S. tax. Under the proposal, an individual who qualifies under this proposal will not be subject to tax as a U.S. citizen and will not be a covered expatriate subject to the mark-to-market exit tax under § 877A.

X. BEPS: FINAL REPORTS.

- A. The OECD released final BEPS reports on October 5, 2015. Pascal Saint-Amans, Director of the OECD’s BEPS project, discussed the 13 reports that day in a webcast. They are addressed in an excellent report in Tax Notes Today by Stephanie Soong Johnston to which Lee Sheppard, Amanda Athanasiou, Mindy Herzfeld, Ajay Gupta, Ryan Finley and J.P. Finet made significant contributions. They also had some very good follow-up reports. Alison Bennett, Dolores Gregory, Rick Mitchell, Alex Parker, Joe Kirwin, Laura Davidson, Michael Scaturro and Kevin Bell have also had excellent reports published in Bloomberg BNA.
- B. The OECD’s Introduction states that the BEPS package lays the foundations of a “modern international tax framework under which profits will be taxed where economic activity and value creation occurs.” It says that “it is now time to focus on the upcoming challenges, which include supporting the implementation of the recommended changes in a consistent and coherent manner, monitoring the impact on double non-taxation and on double taxation, and designing a more inclusive framework to support implementation and carry out monitoring.”
- C. The Introduction says that some of the revisions may be immediately applicable, such as the revisions to the Transfer Pricing Guidelines,<sup>4</sup> while others will require changes that can be implemented by tax treaties, including through the BEPS’ multilateral instrument. Some will require domestic law changes, such as the provisions on hybrid mismatches, CFCs, interest deductibility, country-by-country reporting, and the mandatory disclosure rules. Preferential IP regimes will need to be aligned with the harmful tax practices criteria.
- D. The Introduction further states that challenges arose during the development process: some countries enacted unilateral measures, some tax administrations

---

<sup>4</sup> This perhaps is overly optimistic. The TPGs have to be formally approved by the OECD Council, an event that will not occur until after the G20 Leaders approve the final reports. After approval, the process of implementation varies by country. Some countries will automatically incorporate the changes, while others need to go through a legislative process. In the U.S., of course, we have our own § 482 regulations that do not directly reference the OECD’s TPGs.



have been more aggressive, and the increasing uncertainty has been denounced by some practitioners. The BEPS writers say that governments recognize these challenges and that consistent implementation and application will be the key to success. Accordingly, the OECD and the G20 countries have agreed to continue to work together to support an efficient and consistent implementation of the BEPS project framework.

E. Action #1 – Digital Economy.

1. The Action #1 Executive Summary says that the digital economy is increasingly becoming the economy itself. Thus, it would be difficult, if not impossible, to ring-fence the digital economy from the rest of the economy for tax purposes. The digital economy and its business models nevertheless present some key features that are relevant from a tax perspective. The work on the relevant BEPS provisions took these issues into account to ensure that the proposed solutions fully address the digital economy.
2. Accordingly, it was agreed to modify the list of exceptions to the definition of permanent establishment (“PE”) to ensure that each of the exceptions included therein is restricted to activities that are otherwise of a “preparatory or auxiliary” character, and to introduce a new anti-fragmentation rule to prevent the use of these exceptions through the fragmentation of business activities among closely-related enterprises.
3. For example, the maintenance of a very large warehouse in which a significant number of employees work for purposes of storing and delivering goods sold online to customers of a foreign online seller of physical products (whose business model relies on proximity to customers and quick delivery to clients) would constitute a PE of the seller under the new standard.
4. The definition of PE also was modified to address circumstances in which artificial arrangements relating to the sales of goods or services of one company in a multinational group effectively result in the conclusion of contracts, such that the sales should be treated as if they have been made by that company.
5. Thus, if the sales force of a local subsidiary of a foreign online seller of tangible products or an online provider of advertising services habitually plays the principal role in the conclusion of contracts with prospective large clients for those products or services, and these contracts are routinely concluded without material modification by the parent company, this activity would result in a PE for the parent company.
6. Further, under the revised transfer pricing guidance, legal ownership alone does not necessarily generate a right to all (or indeed any) of the return

that is generated by the exploitation of the intangible. Instead, the group companies performing the important functions, contributing the important assets and controlling economically significant risks, as determined through an analysis of the actual transaction, will be entitled to an appropriate return.

7. The controlled foreign corporation (“CFC”) proposals also would treat income that is typically earned in the digital economy as subject to taxation in the jurisdiction of the ultimate parent company (*i.e.*, like Subpart F income), with the aim of eliminating so-called stateless income.
8. The BEPS task force did not recommend any of the three options that it previously had considered for taxing income from the sales of digital goods and services by foreign suppliers lacking a permanent establishment in the customers’ country under current treaty rules. The proposals were a withholding tax on income from certain kinds of digital transactions, a new nexus rule in the form of a significant economic presence, and an equalization levy to tax the non-resident enterprise’s significant economic presence in the given country.
9. However, the report suggests that countries could implement any of the three options to further protect against base erosion and profit shifting, as long as they respect existing treaty obligations and adapt the rules to ensure consistency with existing international commitments.
10. A U.S. spokesperson (Bob Stack) said the language regarding the three options represents a compromise on a sticky issue, but expressed the view that, as written, there is not a lot of freedom for countries to adopt any of the options.
11. The report also recommended that countries apply the OECD’s International VAT/GST Guidelines for the collection of VAT on cross-border transactions and consider implementing the collection mechanisms described in those guidelines.
12. The report states that its conclusions may evolve as the digital economy continues to develop. Thus, it is important to continue working on these issues and to monitor developments over time. Thus, the work will continue following completion of the other follow-up work on BEPS projects. This future work will be done in consultation with a broad range of stakeholders, and on the basis of a detailed mandate to be developed during 2016 in the context of designing an inclusive post-BEPS monitoring process.
13. The Digital Economy Final Report is the second-longest of the BEPS reports at 285 pages.

F. Action #2 – Hybrids.

1. Hybrid mismatch arrangements exploit differences in the tax treatment of an entity or instrument under the laws of two or more tax jurisdictions to achieve double non-taxation, including long-term deferral. The Action #2 Executive Summary says these types of arrangements are widespread and result in a substantial erosion of the taxable bases of the countries concerned.
2. Part 1 of the Final Report provides recommendations for rules to address mismatches in tax outcomes when they arise regarding payments made under a hybrid financial instrument or those made to or by a hybrid entity. It also recommends rules to address indirect mismatches that arise when the effects of a hybrid mismatch arrangement are imported into a third jurisdiction. The recommendations take the form of linking rules that align the tax treatment of an instrument or entity with the tax treatment in the counterparty jurisdiction but otherwise do not disturb the commercial outcomes.
3. The rules apply automatically, and there is a primary rule and a secondary, or defensive, rule. This prevents more than one country from applying the rule for the same arrangement and avoids double taxation.
4. The recommended primary rule is that countries deny the taxpayer's deduction for a payment to the extent that it is not included in the taxable income of the recipient in the counterparty jurisdiction or it is also deductible in the counterparty jurisdiction. If the primary rule does not apply, then the counterparty jurisdiction can generally apply a defensive rule, requiring the deductible payment to be included in income or denying the duplicate deduction, depending on the nature of the mismatch.
5. Part 2 addresses rules designed to ensure that hybrid instruments and entities, as well as dual resident entities, are not used to improperly obtain the benefits of tax treaties and that tax treaties do not prevent the application of the changes to domestic law recommended in Part 1.
6. It states that Action 6 (treaties) will address some of the BEPS concerns related to dual resident entities. Cases involving dual residence under a tax treaty will be resolved on a case-by-case basis, rather than on the basis of the current rule and the place of effective management. This change, however, will not address all BEPS concerns related to dual resident entities. Domestic law changes will be necessary to address other avoidance strategies involving dual residence.
7. Part 2 proposes to include in the OECD model tax convention a new provision and detailed commentary that will ensure that benefits of tax treaties are granted in appropriate cases to the income of hybrid entities

but also that these benefits are not granted where neither state treats, under its domestic law, the income of such an entity as the income of one of its residents.

8. Finally, Part 2 addresses potential treaty issues that could arise from the recommendations in Part 1. The report describes possible treaty changes that would address these issues.
  9. I note the three-part paper written by Bob Cassanos of Fried, Frank that addressed the BEPS hybrid mismatch rules. Cassanos made a number of suggestions for improving the BEPS hybrid mismatch rules, which he believes will fall short in practice. He states that one area in which the approach falls short is properly allocating the missing tax base to the correct taxpayers. He also expressed concern about the ambiguity of the basis for comparison, the ambiguity of the scope, the difficulties of interpreting and knowing when to apply the rules, and the complex web of overlapping and under- and over-inclusion remedies that all contribute to a less-than-satisfying resolution of the issue. Cassanos said that there already is a simpler approach for dealing with situations in which, for example, there is a deduction of interest and no inclusion of the interest income anywhere: withholding of income at the source.
  10. Bob's suggestions would seem now to be history, and the easy way out will not supplant the complex proposed new rules. Unfortunately, the report explaining the proposed new hybrid rules is an incredible 454 pages in length, far lengthier than Bob's paper and more than double the number of pages in the Final Report's discussion of the new transfer pricing rules (186 pages).
  11. The Final Report also contains some additions to the hybrid rules that would make them even more complex, most notably those addressing hybrid transfers, which includes repos and securities lending transactions. In addition, a special new rule would deal with disregarded payments made by hybrid entities. A disregarded payment would be one that the payee jurisdiction does not see. The payer jurisdiction would be expected to deny a deduction, and failing that, the payee jurisdiction would be expected to require inclusion.
- G. Action #3 - CFC Rules. This report sets out CFC recommendations, which are described as "building blocks." The recommendations are not minimum standards, but are designed to ensure that jurisdictions that choose to implement them will have rules that effectively prevent taxpayers from shifting income to foreign subsidiaries. The report retains much of what was in the discussion draft, released April 3, as well as the sense that the various options reflect a deep lack of consensus among the stakeholders. A U.S. spokesperson indeed expressed disappointment that a consensus could not be reached on CFC rules.

H. Action #4 – Interest.

1. The BEPS Action #4 Final Report does not differ significantly from the earlier discussion draft, which presented a number of choices and left restrictions up to individual countries.
2. The Final Report, however, seemingly provides more direction. It analyzes several “best practices” and then provides a suggested approach. The recommended approach is based on a fixed ratio rule that limits an entity’s net deductions for interest and payments economically equivalent to interest to a percentage of its earnings before interest, taxes, depreciation and amortization (EBITDA). At a minimum, states the Action #4 Executive Summary, this should apply to entities in multinational groups.
3. The recommended approach includes a range of possible ratios of between 10% and 30% to ensure that countries apply a fixed ratio that is sufficiently low to deal with base erosion issues while at the same time recognizing that all countries are not in the same position. The report also includes factors that countries should take into account in setting their fixed ratio within this range.
4. The fixed-ratio approach can be supplemented with a worldwide-group ratio rule that allows an entity to exceed the fixed-ratio limit in certain circumstances. Using a worldwide-group ratio along with a fixed ratio would allow an entity with net interest expense above a country’s fixed ratio to deduct interest up to the level of the net interest/EBITDA ratio of its worldwide group.
5. Countries may also apply an uplift of up to 10% to the group’s net third-party interest expense to prevent double taxation. The earnings-based worldwide-group ratio rule also could be replaced by different group-ratio rules, such as the “equity escape” rule (which compares an entity’s level of equity and assets to those of its group) currently in place in some countries. A country may also choose not to introduce any group-ratio rule. If a country does not introduce a group-ratio rule, it should apply the fixed ratio to entities in multinational and domestic groups without improper discrimination.
6. The recommended approach allows countries to supplement the fixed-ratio and group-ratio rules with other provisions that reduce the impact of the rules on entities or in situations which pose less BEPS risk. The report also recognizes that the banking and insurance sectors have specific features that must be taken into account and that there is a need to develop suitable rules that address BEPS risks in these sectors.

I. Action #5 – Harmful Tax Practices.

1. The participating countries agreed that the substantial activity requirement used to assess preferential regimes should be strengthened in order to re-align taxation of profits with the substantial activities that generate them. Several approaches were considered and consensus was reached on a “nexus approach.”
2. This approach was developed in the context of IP regimes, and allows a taxpayer to benefit from an IP regime only to the extent that the taxpayer itself incurred qualifying research and development (“R&D”) expenditures that gave rise to the IP income. The nexus approach uses expenditures as a proxy for activity and builds on the principle that, because IP regimes are designed to encourage R&D activities and to foster growth and employment, a substantial activity requirement should ensure that taxpayers benefiting from these regimes did in fact engage in the activities and did incur the actual expenditures regarding these activities. Saint-Amans said in his webcast that the nexus approach will ultimately limit the toxicity of patent boxes.
3. In the area of transparency, there was an agreement regarding the exchange of rulings that could give rise to BEPS concerns. There will be a compulsory spontaneous exchange of rulings related to: (1) preferential regimes; (2) cross-border unilateral advance pricing agreements or other unilateral transfer pricing rulings; (3) a downward adjustment to profits; (4) permanent establishments; and (5) conduits. Other categories of rulings can be added to the list if the OECD’s Forum on Harmful Tax Practices agrees that the absence of an exchange would give rise to BEPS concerns.
4. The Final Report states that an inclusion on the list does not mean that these rulings are *per se* preferential or that they will in themselves give rise to BEPS issues, but it does acknowledge that a lack of transparency in the operation of a regime or administrative process can give rise to mismatches in tax treatment and instances of double non-taxation. For countries that have the necessary legal basis in place, an exchange of information will take place starting April 1, 2016 for future rulings. The exchange of certain past rulings will need to be completed by December 31, 2016. The report also provides best practices for cross-border rulings.
5. The Report includes a review of 43 preferential regimes, 16 of which are IP regimes. In respect of substantial activity, the IP regimes reviewed were all considered inconsistent, either in whole or in part, with the nexus approach described in the report. Countries with these regimes will now need to review them for possible changes to conform. The BEPS review process will be ongoing.

J. Action #6 – Treaty Abuse.

1. The Action #6 Executive Summary says that taxpayers engaged in treaty shopping and other treaty abuse strategies undermine tax sovereignty by claiming treaty benefits in situations in which these benefits were not intended to be granted, thereby depriving countries of tax revenues. The BEPS participant countries have therefore agreed to include anti-abuse provisions in their tax treaties, including a minimum standard to counter treaty shopping.
2. Section A of the Final Report includes new treaty anti-abuse rules that provide safeguards against the abuse of treaty provisions and offer a certain degree of flexibility regarding how to do so. These new treaty anti-abuse rules first address treaty shopping, which involves strategies through which a person that is not a resident of a state attempts to obtain benefits that a tax treaty concluded by that state grants to residents of the state, for example, by establishing a letterbox company in that state.
3. The following approach is recommended to deal with these strategies: (1) provide a clear statement that the states that enter into a tax treaty intend to avoid creating opportunities for non-taxation or reduced taxation through tax evasion or avoidance, including treaty shopping arrangements; (2) include a specific anti-abuse rule, the limitation-on-benefits (LOB) rule, that limits the availability of treaty benefits to entities that meet certain conditions in the OECD model tax convention; and (3) include a more general anti-abuse rule based on the principal purpose of transactions or arrangements (the principal purpose test (“PPT”)) in the OECD model tax convention. The latter provision is to address other forms of treaty abuse, including treaty shopping situations that would not be covered by an LOB rule.
4. The report recognizes that each of the LOB and PPT rules has strengths and weaknesses and may not be appropriate for, or accord with treaty policy of, all countries. Also, the domestic law of some countries may include provisions that make it unnecessary to combine these rules to prevent treaty shopping.
5. The participating BEPS countries have committed to ensure a minimum level of protection against treaty shopping (the minimum standard). This commitment will require countries to include in their tax treaties an express statement that their common intention is to eliminate double taxation without creating opportunities for non-taxation or reduced taxation through tax evasion or avoidance, including through treaty shopping arrangements.
6. The U.S. will not utilize a PPT approach in its treaties. Such an approach was rejected by the Senate several years ago. Nearly all U.S. treaties, of

course, contain an LOB provision. The U.S. also has domestic rules to help prevent treaty shopping (anti-conduit rules under § 881). Thus, the U.S. will be compliant. Nonetheless, U.S. tax advisors will need to understand the new PPT rules. They likely will find themselves dealing with foreign-to-foreign treaties in their practices.

7. Section A also provides new rules to be included in tax treaties in order to address other forms of treaty abuse. These targeted rules address: (1) certain dividend transfer transactions that are intended to artificially lower withholding taxes payable on dividends; (2) transactions that circumvent the application of the treaty that allows source taxation of shares of companies that derive their value primarily from movable property; (3) situations in which an entity is a resident of two contracting states; and (4) situations in which the state of residence exempts the income of permanent establishments situated in third states and where shares, debt claims, rights or property are transferred to permanent establishments set up in countries that do not tax that income or offer preferential treatment to that income.
8. Changes to the commentary to the OECD model tax treaty convention will clarify that treaties do not prevent application of the contracting state's right to tax its own residents or imposition of a so-called "departure" or "exit" tax under which liability to tax some types of income that has accrued for the benefit of a resident is triggered in the event that the resident ceases to be a resident of that state.
9. Section B of the report addresses the part of Action 6 that seeks clarification "that tax treaties are not intended to be used to generate non-taxation." This clarification is provided through a reformulation of the title and preamble of the model tax convention that will state that the joint intention of the parties to a treaty is to eliminate double taxation without creating opportunities for tax evasion and avoidance, in particular through treaty shopping arrangements.
10. Section C of the report addresses the third part of the work mandated by Action 6, which is "to identify the tax policy considerations that, in general, countries should consider before deciding to enter into a tax treaty with another country."
11. Additional work will be required to fully consider proposals recently released by the U.S. concerning the LOB rule and other provisions included in the report. Since the U.S. does not anticipate finalizing its new model tax treaty until the end of 2015, the relevant provisions included in the report will need to be reviewed after that finalization and will therefore be finalized in the first part of 2016. An examination of the issues related to the treaty entitlement of certain types of investment funds will also continue after September 2015 with a similar deadline.



K. Action #7 – PE Status. Action #7 is entitled “Preventing the Artificial Avoidance of Permanent Establishment Status.”

1. Commissionaires.

- (a) Commissionaire arrangements, a specific target of Action #7, may loosely be defined as an arrangement through which a person sells products in a state in its own name, but on behalf of a foreign enterprise that is the owner of the products. Through such an arrangement, the foreign enterprise is able to sell its products in a state without technically having a PE in that state to which the sales may be attributed for tax purposes and without, therefore, being taxable in that state on the profits derived from those sales. Commissionaire arrangements have been a major preoccupation of the tax administrations in many countries, as shown by the number of cases dealing with these arrangements that have been litigated in OECD countries. In most of the cases that went to court, the tax administration’s arguments were rejected.
- (b) The Executive Summary states that, as a matter of policy, where the activities that an intermediary exercises in a country are intended to result in the regular conclusion of contracts to be performed by a foreign enterprise, that enterprise should be considered to have a taxable presence in the country unless the intermediary is performing these activities in the course of an independent business. Changes to Articles 5(5) and 5(6) of the OECD model tax convention and the related commentary that is included in Section A of the report address commissionaire arrangements and similar strategies by ensuring that the wording of these provisions better reflects this underlying policy.

2. Habitually Concludes Contracts.

- (a) Commentors on the discussion draft’s broadening of the term “habitually concludes contracts” to the term “habitually concludes contracts or negotiates the material elements of contracts” were concerned that the proposed new rule was so broadly worded that it could apply to some of the most basic business practices of modern multinational enterprises and that it would capture much more than simply commissionaire arrangements. They also were concerned that it would apply to many transactions that do not raise BEPS-related concerns.
- (b) The Tax Executives Institute (“TEI”) stated, for example, that many businesses require goods and services to be delivered in multiple locations around the world. To ensure that the goods and services are always provided under the same terms and conditions

and meet the same standards, a global master sales or service agreement is often negotiated by a lead provider (for example, the parent company) to save time in negotiation and administration of contracts. The master agreement's terms are then incorporated by reference into local agreements with local subsidiaries. The local agreement is reviewed, approved and signed by the local subsidiary; however, to keep each local subsidiary from re-negotiating the contract, modifications are generally limited to changes that are necessary because of specific local business needs or to satisfy local legal, tax and other regulatory requirements.

- (c) TEI was concerned that under the discussion draft, the parent company likely would have a permanent establishment in each location that a local agreement is executed based on the master services agreement. Given that the local subsidiary is already paying tax for its local activities, the lead service provider that negotiated the global master agreement should not also have a permanent establishment in that jurisdiction merely by virtue of the agreement.
- (d) TEI also was concerned that the proposed commentary in the discussion draft also stretched the interpretation of the phrase "concludes contracts" beyond any reasonable definition. Specifically, it indicated that a contract may be considered to be concluded in a state (1) even without any active negotiation of the terms of that contract, or (2) if a person accepts, on behalf of an enterprise, the offer made by a third party to enter into a standard contract with that enterprise even if the contract is signed outside of that state.
- (e) To address these concerns, the Final Report uses the language habitually "concludes contracts or habitually plays the principal role leading to the conclusion of contracts that are routinely concluded without material modification by the enterprise." The revised commentary says that while the term "concludes contracts"

"provides a relatively well-known test based on contract law, it was found necessary to supplement that test with a test focusing on substantive activities taking place in one State in order to address cases where the conclusion of contracts is clearly the direct result of these activities although the relevant rules of contract law provide that the conclusion of the contract takes place outside that State. The phrase must be interpreted in the light of the object and purpose of paragraph 5, which is to cover cases where the activities that a person exercises in a State are intended to result in the regular conclusion of contracts to be performed by a foreign enterprise, *i.e.* where that person acts as the

sales force of the enterprise. The principal role leading to the conclusion of the contract will therefore typically be associated with the actions of the person who convinced the third party to enter into a contract with the enterprise. The phrase therefore applies where, for example, a person solicits and receives (but does not formally finalise) orders which are sent directly to a warehouse from which goods belonging to the enterprise are delivered and where the enterprise routinely approves these transactions. It does not apply, however, where a person merely promotes and markets goods or services of an enterprise in a way that does not directly result in the conclusion of contracts. Where, for example, representatives of a pharmaceutical enterprise actively promote drugs produced by that enterprise by contacting doctors that subsequently prescribe these drugs, that marketing activity does not directly result in the conclusion of contracts between the doctors and the enterprise so that the paragraph does not apply even though the sales of these drugs may significantly increase as a result of that marketing activity.

“The following is another example that illustrates the application of paragraph 5. RCO, a company resident of State R, distributes various products and services worldwide through its websites, SCO, a company resident of State S, is a wholly-owned subsidiary of RCO. SCO’s employees send emails, make telephone calls to, or visit large organisations in order to convince them to buy RCO’s products and services and are therefore responsible for large accounts in State S; SCO’s employees, whose remuneration is partially based on the revenues derived by RCO from the holders of these accounts, use their relationship building skills to try to anticipate the needs of these account holders and to convince them to acquire the products and services offered by RCO. When one of these account holders is persuaded by an employee of SCO to purchase a given quantity of goods or services, the employee indicates the price that will be payable for that quantity, indicates that a contract must be concluded online with RCO before the goods or services can be provided by RCO and explains the standard terms of RCO’s contracts, including the fixed price structure used by RCO, which the employee is not authorized to modify. The account holder subsequently concludes that contract online for the quantity discussed with SCO’s employee and in accordance with the price structure presented by that employee. In this example, SCO’s employees play the principal role leading to the conclusion of the contract between the account holder and RCO and such contracts are routinely concluded without material modification by the enterprise. The fact that SCO’s employees cannot vary the terms of the contracts does not mean that the conclusion of

the contracts is not the direct result of the activities that they perform on behalf of the enterprise, convincing the account holder to accept these standard terms being the crucial element leading to the conclusion of the contracts between the account holder and RCO.”

- (f) A U.S. spokesperson stated that the U.S. was pleased with this change in language from that proposed in the earlier discussion draft.

3. Preparatory or Auxiliary.

- (a) When the specific exceptions to the definition of PE in Article 5(4) of the OECD model tax convention were first introduced, the described activities were generally considered to be of a preparatory or auxiliary nature.
- (b) The Executive Summary to the Action #7 Final Report says there have been dramatic changes in the way that business is conducted since the introduction of these exceptions. This was discussed in part in the Final Report on Action 1 (“Digital Economy”). Depending on the circumstances, activities previously considered to be merely preparatory or auxiliary in nature may today correspond to core business activities. In order to ensure that profits derived from core activities performed in a country can be taxed in that country, Article 5(4) will be modified to ensure that each of the exceptions included therein is restricted to activities that are otherwise of a “preparatory or auxiliary” character.
- (c) Commentors on the earlier discussion draft had objected to various options proposed as replacements to the present rules. The BEPS draftpersons decided that the “preparatory or auxiliary” approach would work best, with a clarification of the scope of this term. The U.S. disagreed with this approach on the grounds that the standard “preparatory or auxiliary” is too subjective. Some countries believe the issue should be resolved by the anti-fragmentation rule, discussed below.
- (d) Accordingly, the Final Draft, while adding the “preparatory or auxiliary” limiting language to the OECD model treaty, also provides that it is optional, provided countries that do not include it as an overall limitation include an anti-fragmentation provision in their treaties.
- (e) The new limiting provision (“preparatory or auxiliary”) will be discussed in the OECD model convention commentary as follows:

“It is often difficult to distinguish between activities which have a preparatory or auxiliary character and those which have not. The decisive criterion is whether or not the activity of the fixed place of business in itself forms an essential and significant part of the activity of the enterprise as a whole. Each individual case will have to be examined on its own merits. In any case, a fixed place of business whose general purpose is one which is identical to the general purpose of the whole enterprise, does not exercise a preparatory or auxiliary activity.

“As a general rule, an activity that has a preparatory character is one that is carried on in contemplation of the carrying on of what constitutes the essential and significant part of the activity of the enterprise as a whole. Since a preparatory activity precedes another activity, it will often be carried on during a relatively short period, the duration of that period being determined by the nature of the core activities of the enterprise. This, however, will not always be the case as it is possible to carry on an activity at a given place for a substantial period of time in preparation for activities that take place somewhere else. Where, for example, a construction enterprise trains its employees at one place before these employees are sent to work at remote work sites located in other countries, the training that takes place at the first location constitutes a preparatory activity for that enterprise. An activity that has an auxiliary character, on the other hand, generally corresponds to an activity that is carried on to support, without being part of, the essential and significant part of the activity of the enterprise as a whole. It is unlikely that an activity that requires a significant proportion of the assets or employees of the enterprise could be considered as having an auxiliary character.”

4. Fragmentation.

- (a) BEPS concerns related to Article 5(4) also arise from what the report calls the “fragmentation of activities.” The Executive Summary states that given the ease with which multinational enterprises may alter their structures to obtain tax advantages, it is important to clarify that PE status cannot be avoided by fragmenting a cohesive operating business into several small operations in order to argue that each part is merely engaged in preparatory or auxiliary activities that benefit from the exceptions of Article 5(4). The U.S. agreed with the need for an anti-fragmentation rule.
- (b) However, the vast majority of comments regarding the discussion draft’s fragmentation proposals objected to both proposed

approaches to changing the rule. All commenters agreed that a fragmentation rule would be difficult to apply in practice, even those few who supported a change. TEI stated that many multinational enterprises are divided functionally on a worldwide basis so that, for example, the purchasing function is separated from the manufacturing function, which is separated from the sales function. Each of these corporate functions has its own management, reporting lines and financial statements. Commercial advantage is the primary driver for utilizing the specialization, expertise, economies of scale, and flexibility that accompanies this manner of conducting worldwide operations.

- (c) TEI's specific concern was that an anti-fragmentation rule could cause a multinational enterprise to have multiple PE's in a given country or a PE in situations in which there really should not be a PE, for example, where there are no BEPS concerns, simply by having a rule that fails to recognize how large modern corporate enterprises operate in today's business environment.
- (d) The new anti-fragmentation language in Article 5 (4.1) will provide:

“Paragraph 4 shall not apply to a fixed place of business that is used or maintained by an enterprise if the same enterprise or a closely related enterprise carries on business activities at the same place or at another place in the same Contracting State and

- a) that place or other place constitutes a permanent establishment for the enterprise or the closely related enterprise under the provisions of this Article, or
- b) the overall activity resulting from the combination of the activities carried on by the two enterprises at the same place, or by the same enterprise or closely related enterprises at the two places, is not of a preparatory or auxiliary character,

provided that the business activities carried on by the two enterprises at the same place, or by the same enterprise or closely related enterprises at the two places, constitute complementary functions that are part of a cohesive business operation.”

- (e) The OECD model treaty commentary will provide:

“The purpose of paragraph 4.1 [above] is to prevent an enterprise or a group of closely related enterprises from fragmenting a cohesive business operation into several small

operations in order to argue that each is merely engaged in a preparatory or auxiliary activity. Under paragraph 4.1, the exceptions provided for by paragraph 4 do not apply to a place of business that would otherwise constitute a permanent establishment where the activities carried on at that place and other activities of the same enterprise or of closely related enterprises exercised at that place or at another place in the same State constitute complementary functions that are part of a cohesive business operation. For paragraph 4.1 to apply, however, at least one of the places where these activities are exercised must constitute a permanent establishment or, if that is not the case, the overall activity resulting from the combination of the relevant activities must go beyond what is merely preparatory or auxiliary.

\* \* \*

“The following examples illustrate the application of paragraph 4.1:

Example A: RCO, a bank resident of State R, has a number of branches in State S which constitute permanent establishments. It also has a separate office in State S where a few employees verify information provided by clients that have made loan applications at these different branches. The results of the verifications done by the employees are forwarded to the headquarters of RCO in State R where other employees analyse the information included in the loan applications and provide reports to the branches where the decisions to grant the loans are made. In that case, the exceptions of paragraph 4 will not apply to the office because another place (*i.e.* any of the other branches where the loan applications are made) constitutes a permanent establishment of RCO in State S and the business activities carried on by RCO at the office and at the relevant branch constitute complementary functions that are part of a cohesive business operation (*i.e.* providing loans to clients in State S).

“Example B: RCO, a company resident of State R, manufactures and sells appliances. SCO, a resident of State S that is a wholly-owned subsidiary of RCO, owns a store where it sells appliances that it acquires from RCO. RCO also owns a small warehouse in State S where it stores a few large items that are identical to some of those displayed in the store owned by SCO. When a customer buys such a large item from SCO, SCO employees go to the warehouse where they take possession of the item before delivering it to the

customer; the ownership of the item is only acquired by SCO from RCO when the item leaves the warehouse. In this case, paragraph 4.1 prevents the application of the exceptions of paragraph 4 to the warehouse and it will not be necessary, therefore, to determine whether paragraph 4, and in particular subparagraph 4 a), applies to the warehouse. The conditions for the application of paragraph 4.1 are met because

- SCO and RCO are closely related enterprises;
- SCO's store constitutes a permanent establishment of SCO (the definition of permanent establishment is not limited to situations where a resident of one Contracting State uses or maintains a fixed place of business in the other State; it applies equally where an enterprise of one State uses or maintains a fixed place of business in that same State); and
- The business activities carried on by RCO at its warehouse and by SCO at its store constitute complementary functions that are part of a cohesive business operation (*i.e.* storing goods in one place for the purpose of delivering these goods as part of the obligations resulting from the sale of these goods through another place in the same State)."

5. Splitting-Up Contracts. The Executive Summary says that the exception in Article 5(3), which applies to construction sites, also has given rise to abuses through the practice of splitting up contracts between closely related enterprises. The PPT that will be added to the OECD model tax convention as a result of Action 6 will address the BEPS concerns related to these abuses. In order to make this clear, a new example will be added to the commentary on the PPT rules.
6. Multilateral Instrument. The changes to the definition of PE that are included in the report will be among the changes proposed for inclusion in the multilateral instrument that will implement the results of the BEPS work on treaty issues.
7. PE Profits. In order to provide greater certainty about the determination of profits to be attributed to a PE and to take account of the need for additional guidance on the issue of attribution and profits to PEs, follow-up work on attribution and profits issues related to Action 7 will be carried on with a view to providing the necessary guidance before the end of 2016, which is a deadline for the negotiation of the multilateral instrument.



L. Actions #8 - #10 – Transfer Pricing.

1. The arm's-length principle is used by countries as the cornerstone of transfer pricing rules. The Executive Summary states that it is embedded in treaties and appears in Article 9(1) of the OECD and UN model tax conventions. A shared interpretation of the arm's-length principle by many of those countries is provided in the OECD's transfer pricing guidelines for multinational enterprises and tax administrations. The BEPS action plan required guidance on the arm's-length principle to be clarified and strengthened and, furthermore, if transfer pricing risks remain after clarifying and strengthening the guidance, the BEPS action plan foresaw the possibility of introducing "special measures" either within or beyond the arm's-length principle.
2. The work on transfer pricing focused on three key areas. Work under Action 8 considered transfer pricing issues relating to intangibles, since misallocation of the profits generated by valuable intangibles has contributed to base erosion and profit-shifting.
3. Work under Action 9 addressed the contractual allocation of risks, and the resulting allocation of profits to those risks, which may not correspond to the activities actually carried on. The work also addressed the level of returns to funding provided by a capital-rich multinational group member where those returns do not correspond to the level of activity undertaken by the funding company.
4. The Action 10 efforts focused on other high-risk areas, including addressing profit allocations resulting from transactions that are not commercially rational for the individual enterprises concerned (re-characterization), targeting the use of transfer pricing methods in a way that results in diverting profits away from the most economically important activities of the multinational group, and neutralizing the use of certain types of payments between members of the multinational group (such as management fees and head office expenses) to erode the tax base in the absence of alignment with value creation.
5. As noted earlier, the BEPS Final Report's Introduction states that the new Transfer Pricing Guidelines may be immediately applicable with no further action needed on the part of participating countries. This is perhaps optimistic. *See* footnote 4 on p. 126 regarding implementation. A U.S. spokesperson (Bob Stack) stated that the BEPS Final Report on Actions 8-10 clarifies the arm's-length standards that are already in the IRS regulations and that Treasury and the IRS do not anticipate making substantial changes to the § 482 regulations.

6. Commercial Rationality.

- (a) The revised transfer pricing guidance requires careful analysis of the actual transaction between associated enterprises by considering the contractual relations between the parties in combination with the conduct of the parties. Their conduct will supplement or replace the contractual arrangements if the contracts are incomplete or not supported by the parties' conduct. The Executive Summary states that in combination with the proper application of pricing methods in a way that prevents the allocation of profits to locations where no contributions are made to these profits, this will lead to the allocation of profits to the enterprises that conduct the corresponding business activities. In circumstances where the transaction between associated enterprises lacks commercial rationality, the guidance authorizes disregarding the arrangement for transfer pricing purposes.
- (b) Use of the term "commercial rationality" represents a change in the Final Report for transactions to be recognized from the earlier approach that transactions must have had fundamental attributes of transactions between unrelated parties to be recognized. The concern, as stated by a U.S. spokesperson (Treasury's Michael McDonald, who served as co-chair of the relevant OECD Working Party), was that the discussion draft's standard could have been interpreted too broadly whereas the intent is to provide nonrecognition of transactions only in exceptional circumstances.

7. Risk and Intangibles.

- (a) The revised guidance includes two important clarifications relating to risks and intangibles.
- (b) Risks are defined as the effect of uncertainty on the objectives of the business. Uncertainty exists and risk is assumed in a company's operations every time steps are taken to exploit opportunities and every time a company spends money to generate income. No profit-seeking business takes on risk associated with commercial opportunities without expecting a positive return.
- (c) The Executive Summary states that this economic notion that higher risks warrant anticipated returns made multinational groups pursue tax-planning strategies based on contractual re-allocations of risks, sometimes without any change in business operations.
- (d) In order to address this, the report provides that risks contractually assumed by a party that cannot in fact exercise meaningful and specifically defined control over the risks, or does not have the

financial capacity to assume the risks, will be allocated to the party that does exercise that control and does have the financial capacity to assume the risks.

- (e) A U.S. spokesperson stated that the report more clearly gives equal weight to functions, assets and risks. One interpretation of the 2014 discussion draft was that risk could be allocated to functions, which was not the intended meaning.
- (f) For intangibles, the guidance clarifies that legal ownership alone does not necessarily generate a right to all (or indeed any) of the return that is generated by the exploitation of the intangible. The group companies performing important functions, controlling economically significant risks and contributing assets, as determined through the accurate delineation of the actual transaction, will be entitled to an appropriate return reflecting the value of their contributions. Specific guidance will ensure that the analysis is not weakened by information asymmetries between the tax administration and the taxpayer in relation to hard-to-value intangibles (*see* the discussion in the next section regarding the OECD Transfer Pricing Guidelines), or by using special contractual relationships, such as a cross-contribution agreement.
- (g) The final guidance also addresses the situation when a capital-rich member of the group provides funding but performs few activities. If this associated enterprise does not in fact control the financial risks associated with this funding (for example, because it just provides the money when it is asked to do so, without any assessment of whether the party receiving the money is credit-worthy), then it will not be allocated profits associated with the financial risks and will be entitled to no more than a risk-free return, or less if, for example, the transaction is not commercially rational and therefore the guidance on non-recognition applies.
- (h) Finally, the guidance ensures that transfer pricing principles will allocate profits to the most important economic activities. It also will not be possible to allocate the synergistic benefits of operating as a group to members other than the ones contributing to the synergistic benefits. For example, discounts that are generated because of the value of goods ordered by a combination of group companies will need to be allocated to those group companies.

8. Profit Split. Follow-up work will be done regarding the transactional profit-split method during 2016 that will be finalized in the first half of 2017. This work should lead to detailed guidance on the ways in which this method can usefully and appropriately be applied to align transfer pricing outcomes and value creation, including in the circumstances of

integrated global value chains. A U.S. spokesperson, in any event, said the U.S. is reluctant to push taxpayers towards using profit split methods when traditional pricing models using valuation methods and comparables will suffice.

9. Related Guidance.

- (a) The Final Report's guidance is linked with other BEPS actions. This guidance will ensure that capital-rich entities without any other relevant economic activities ("cash boxes") will not be entitled to any excess profits. The profits the cash box is entitled to retain will be equivalent to no more than a risk-free return. Moreover, if this return qualifies as interest or an economically equivalent payment, then those already marginal profits will also be targeted by the interest deductibility rules of Action 4.
- (b) In addition, it will become extremely difficult to structure the payments to the country where the cash box is tax-resident in a way that avoids withholding taxes, due to the guidance on preventing treaty abuse (Action 6). Finally, a cash box with limited or no economic activities is likely to be the target of CFC rules (Action 3). The role of cash boxes in base erosion and profit shifting strategies will be seriously discouraged.
- (c) A transfer pricing analysis requires access to the relevant information. Access to the transfer pricing documentation provided by Action 13 will enable the guidance provided in the Final Report to be applied in practice, based on relevant information on global and local operations in the master file and local file. In addition, the country-by-country ("CbC") reports will enable better risk assessment practices by providing information about the global allocation of the multinational group's revenues, profits, taxes and economic activity.
- (d) A U.S. spokesperson said, however, the U.S. is able and willing to suspend information exchange with countries that misuse data taken from CbC reports, such as using things like headcount and making assumptions about allocable profits.

10. Commodities and Developing Countries. The report also contains guidance on transactions involving commodities, as well as on low-value-adding intra-group services. As BEPS creates additional transfer pricing challenges for developing countries, and these two areas were identified by them as being of critical importance, this guidance will be supplemented with further work mandated by the G20 developing-country working group, which will provide knowledge, best practices, and tools for developing countries to use to price commodity transactions for

transfer pricing purposes and to prevent erosion of their tax bases through common types of base-eroding payments.

11. Mutual Agreement Procedures. Transfer pricing depends on a facts-and-circumstances analysis and can involve subjective interpretations of these facts and circumstances. In order to address the risk of double taxation, the work under Action 14 to improve the effectiveness of dispute resolution mechanisms includes a new minimum standard providing for access to the mutual agreement procedures of Article 25 of the model tax convention for all transfer pricing cases. In addition, the 20 countries that have made a commitment to mandatory binding arbitration under Article 14 have specified that they will allow arbitration for transfer pricing cases so that double taxation will be eliminated.
12. Special Measures. The Executive Summary states that the work under Actions 8-10 of the BEPS Action Plan will ensure that transfer pricing outcomes better align with value creation of the multinational group. This will ensure that the role of capital-rich low-functioning entities in base erosion and profit shift planning will become less relevant. As a consequence, the goals set by the BEPS Action Plan in relation to the development of transfer pricing rules have been achieved without the need to develop so-called “special measures” outside the arm’s-length principle.
13. Risk and Re-characterization, Intangibles, etc. The Final Report contains significant revisions regarding risk and re-characterization, intangibles, cost-contribution arrangements and low-value-adding services. The OECD Transfer Pricing Guidelines are materially changed regarding these areas and they are discussed at length in the next section of this outline.

M. Action #11 – Measuring and Monitoring BEPS.

1. The April 16 discussion draft on Action #11 indicated that measuring the scale and effect of base erosion and profit shifting is challenging because of the complexity and the serious data limitations. The Final Report does not improve upon that assessment. However, it nonetheless states in an *ipse dixit* manner that, although measuring the scale of base erosion and profit shifting is challenging, “we know that the fiscal effects of [base erosion and profit shifting] are significant.”
2. The report states that six indicators of this base erosion activity highlight taxpayer base-eroding behaviors using different sources of data, employing different metrics, and examining base erosion channels. The report adds that new empirical analysis of the fiscal and economic effects of base erosion and profit shifting and “hundreds” of existing empirical studies that find the existence of profit shifting through transfer mispricing, strategic location of intangibles and debt, as well as treaty

abuse confirm that profit-shifting is occurring, is significant in scale and likely to be increasing, and creates adverse economic distortions.

3. The report then states, however, that these indicators and all analyses of base erosion and profit shifting are severely constrained by the limitations of the currently available data. The available data is not comprehensive across countries or companies, and often does not include actual taxes paid. In addition, the analyses of profit-shifting to date have found it difficult to separate the effects of profit-shifting from real economic factors and the effects of deliberate government tax policy choices. Improving the tools and data available to measure base erosion and profit shifting will be critical for measuring and monitoring it in the future.
4. The report makes a number of recommendations intended to improve the analysis of the available data while recognizing the need to maintain appropriate safeguards to protect the confidentiality of taxpayer information. The report is the third-longest of the BEPS reports at 268 pages.

N. Action #12 – Mandatory Disclosure Rules.

1. Action 12 addresses mandatory disclosure regimes to fight abusive tax schemes. The Executive Summary states that mandatory disclosure regimes should be clear and easy to understand, should balance additional compliance costs to taxpayers with the benefits obtained by the tax administration, should be effective in achieving their objectives, and should accurately identify the schemes to be disclosed. One objective of mandatory disclosure regimes is deterrence: taxpayers may think twice about entering into a scheme if it has to be disclosed. Pressure is also placed on the tax avoidance market as promoters and users have only a limited opportunity to implement schemes before they are closed down.
2. The Final Report does not set forth a minimum standard and countries are free to choose whether or not to introduce mandatory disclosure regimes. In order to successfully design an effective mandatory disclosure regime, the following features need to be considered: who reports, what information needs to be reported, when the information has to be reported, and the consequences of non-reporting. The report recommends that countries introducing mandatory disclosure regimes consider a list of five specified items, such as, should the disclosure requirement be imposed on both the promoter and the taxpayer or should the primary obligation to disclose be imposed on either the promoter or the taxpayer? Also, penalties should be introduced to ensure compliance with mandatory disclosure regimes that are consistent with general domestic law.

O. Action #13 – Transfer Pricing Documentation and CbC Reporting.

1. The Action #13 Executive Summary states that guidance on transfer pricing documentation requires multinational enterprises to provide tax administrations with high-level information regarding their global business operations and transfer pricing policies in a “master file” that is to be available to all relevant tax administrations.
2. Second, the guidance requires that detailed transactional transfer pricing documentation be provided in a “local file” specific to each country, identifying material-related party transactions, the amounts involved in those transactions, and the company’s analysis of its transfer pricing determinations regarding those transactions.
3. Third, large multinational enterprises are required to file a CbC report that will provide annually and for each tax jurisdiction in which they do business the amount of revenue, profit before income tax and income tax paid and accrued. It also requires multinational enterprises to report the number of their employees, stated capital, retained earnings, and tangible assets in each tax jurisdiction. Finally, it requires multinational enterprises to identify each entity in the group that does business in a particular tax jurisdiction and to provide an indication of the business activities in which each entity engages.
4. The Executive Summary says that consistent and effective implementation of the transfer pricing documentation standards and in particular of the CbC report is essential. Therefore, countries participating in the BEPS project agreed on the core elements of implementing transfer pricing documentation and CbC reporting. This agreement calls for the master file and the local file to be delivered by multinational enterprises directly to local tax administrations. CbC reports should be filed in the jurisdiction of tax residence of the ultimate parent entity and shared between jurisdictions through automatic exchange of information pursuant to government-to-government mechanisms.
5. The new CbC reporting requirements are to be implemented for fiscal years beginning on or after January 1, 2016 and applied, subject to a review in 2020, to multinational enterprises with annual consolidated group revenue equal to or exceeding €750 million.
6. A U.S. spokesperson said temporary regulations to implement CbC reporting for 2016 will be released by Treasury and the IRS before the end of 2015. He emphasized that the CbC reports are for risk assessment purposes only and that the intention is for the templates to give companies flexibility to provide the information in the best way for them. Data for 2016 is to be reported in 2017 and exchanged in 2018.

7. There has been some discussion in the U.S. regarding the IRS's authority to collect CbC information from taxpayers and provide that information to foreign governments. Senator Hatch raised these questions. Recent comments by a Treasury spokesperson (Bob Stack) indicate the Treasury is comfortable that indeed it has this authority.

P. Action #14 – Dispute Resolution Mechanisms.

1. Article 25 of the OECD model tax convention provides a mechanism, independent of ordinary legal remedies available under domestic law, through which the competent authorities of the contracting states may resolve differences or difficulties regarding the interpretation or application of the convention on a mutually-agreed basis. This mechanism—the mutual agreement procedure—is of fundamental importance to the proper application and interpretation of tax treaties, notably to ensure that taxpayers entitled to the benefits of the treaty are not subject to taxation by either of the contracting states which is not in accordance with the terms of the treaty.
2. The BEPS countries have agreed to important changes in their approach to dispute resolution, in particular by having developed a minimum standard with respect to the resolution of treaty-related disputes, committed to its rapid implementation and agreed to ensure its effective implementation through the establishment of a robust peer-based monitoring mechanism that will report regularly through the committee on fiscal affairs to the G20.
3. The minimum standard will: (1) ensure that treaty obligations related to the mutual agreement procedure are fully implemented in good faith and that mutual agreement cases are resolved in a timely manner; (2) ensure the implementation of administrative processes that promote the timely resolution of treaty-related disputes; and (3) ensure that taxpayers can access the mutual agreement procedures when eligible. The BEPS countries' implementation of the minimum standard will be monitored using a detailed terms of reference and assessment methodology to be developed in 2016.
4. A set of 11 best practices also is described in the report. Countries are free to adopt them, and they are not a part of the minimum standard. A U.S. spokesperson (David Varley, acting director of the IRS's transfer pricing operations) expressed disappointment that they were not included as a part of the minimum standard.
5. In addition to the commitment to implement the minimum standard by all countries, 20 countries have declared their commitment to provide for mandatory binding mutual agreement procedure arbitration in their bilateral tax treaties as a mechanism to guarantee that their treaty-related



disputes will be resolved within a specified time frame. The Final Report states that this represents a major step forward. These countries collectively were involved in more than 90% of the outstanding mutual agreement procedure cases at the end of 2013, as reported to the OECD.

6. A U.S. spokesperson expressed optimism that more countries would join the 20 countries that have already agreed to mandatory binding arbitration, although he added that political support will be key to that effort.
7. While binding arbitration is important, some developing countries expressed objections relating to costs, fairness, accessibility, sovereignty, information security and coordination with domestic law. This could present serious problems moving forward as some important developing countries are not included in the list of 20 countries that have agreed to binding mandatory arbitration.

Q. Action #15 – Multilateral Instrument. Action 15 provides for an analysis of the tax and public international law issues related to the development of a multilateral instrument to enable countries that wish to do so to implement measures developed in the course of the work on BEPS and amend bilateral tax treaties. Interested countries will develop a multilateral instrument designed to provide an innovative approach to international tax matters, reflecting the rapidly evolving nature of the global economy and the need to adapt quickly to this evolution.

## XI. BEPS: REVISIONS TO THE OECD’S TRANSFER PRICING GUIDELINES

### A. Guidance for Applying the Arm’s Length Principle.

1. As a part of the BEPS project, and as a part of the BEPS Final Report on Actions 8-10, Chapter I, Section D of the OECD’s Transfer Pricing Guidelines will be deleted in its entirety and replaced with a lengthy new discussion developed in the context of the BEPS work.<sup>5</sup> The new guidance ensures that (1) actual business transactions undertaken by associated enterprises are identified, and transfer pricing is not based on contractual arrangements that do not reflect economic reality; (2) contractual allocations of risk are respected only when they are supported by actual decision-making; (3) capital without functionality will generate no more than a risk-free return, assuring that no premium returns will be allocate to cash boxes without relevant substance; and (4) tax administrations may disregard transactions when the exceptional circumstances of commercial irrationality apply. In combination, the changes are intended to help align transfer pricing outcomes with the value creating activities performed by members of a multinational group.

---

<sup>5</sup> See footnote 4 on p. 126 regarding implementation.

2. Comparability Analysis.

(a) A “comparability analysis” is at the heart of the application of the arm’s length principle. Application of the arm’s length principle is based on a comparison of the conditions in a controlled transaction with the conditions that would have existed had the parties been independent and undertaken a comparable transaction under comparable circumstances. There are two key aspects in such an analysis:

(1) identify the commercial or financial relations between the associated enterprises and the conditions and economically relevant circumstances attaching to those relations in order that the controlled transaction is accurately delineated; and (2) compare the conditions and the economically relevant circumstances of the controlled transaction as accurately delineated with the conditions and the economically relevant circumstances of the comparable transactions between independent enterprises

(b) The economically relevant characteristics or comparability factors that need to be identified in the commercial or financial relations between the associated enterprises in order to accurately delineate the actual transaction can be broadly categorized as follows: (1) the contractual terms of the transaction; (2) the functions performed by each of the parties to the transaction, taking into account assets used and risks assumed, including how those functions relate to the wider generation of value by the multinational group to which the parties belong, the circumstances surrounding the transaction and industry practices; (3) the characteristics of the property transferred or services provided; (4) the economic circumstances of the parties and of the market in which the parties operate; and (5) the business strategies pursued by the parties.

(c) Independent enterprises, when evaluating the terms of a potential transaction, will compare the transaction to the other options realistically available to them, and they will only enter into the transaction if they see no alternative that offers a clearly more attractive opportunity to meet their commercial objectives. Independent enterprises will generally take into account any economically relevant differences between the options realistically available to them (such as differences in the level of risk) when evaluating those options.

3. The Parties' Agreement.

- (a) In situations where a transaction has been formalized by the associated enterprises through written contractual agreements, those agreements provide a starting point for delineating the transaction between them and how the responsibilities, risks, and anticipated outcomes arising from their interaction were intended to be divided at the time of entering into the contract. However, the parties' written contracts alone are unlikely to provide all the information necessary to perform a transfer pricing analysis, or to provide information regarding the relevant contractual terms in sufficient detail. Consideration must be given to the economically relevant characteristics in the other four categories above, taking into account the functions performed, the assets used and risks assumed, together with the characteristics of property transferred or services provided, the economic circumstances of the parties and of the market in which the parties operate, and the business strategies pursued by the parties.

In an example, Company P, the parent company, owns Company S, a wholly owned subsidiary that acts as an agent for Company P's branded products in the Country S market. The agency contract between the two is silent about any marketing and advertising activities in Country S. An analysis determines that Company S launched an intensive media campaign in Country S in order to develop brand awareness. The campaign represents a significant investment for Company S. Based on the evidence provided by the conduct of the parties, it could be concluded that the written contract may not reflect the full extent of the commercial or financial relations between the parties.

- (b) If the characteristics of the transaction that are economically relevant are inconsistent with the written contract, the actual transaction should generally be delineated for purposes of the transfer pricing analysis in accordance with the characteristics of the transaction reflected in the conduct of the parties. Where there is doubt as to what transaction was agreed to between the associated enterprises, it is necessary to take into account all the relevant evidence from the economically relevant characteristics of the transaction.
- (c) In an example to illustrate the concept of differences between written contractual terms and the conduct of the parties,

Company S is a wholly owned subsidiary of Company P.  
The parties have entered into a written contract pursuant to

which Company P licenses intellectual property to Company S for use in Company S's business. Company S agrees to pay a royalty to Company P. Evidence provided by other economically relevant characteristics, and in particular the functions performed, establishes that Company P performs negotiations with third-party customers to achieve sales for Company S, provides regular technical services to support Company S so that Company S can deliver the contracted sales to its customers, and regularly provide staff to enable Company S to fulfill customer orders. A majority of customers insist on including Company P as joint contracting party along with Company S, although fee income under the contract is payable to Company S. The analysis of the commercial or financial relations indicates that Company S is not capable of providing the contracted services to customers without significant support from Company P, and is not developing its own capacity. Under the contract, Company P has given a license to Company S, but in fact controls the business risk and output of Company S such that it has not transferred risk and functions consistent with a licensing agreement, and acts not as the licensor but as the principal. The identification of the actual transaction between Company P and Company S should not be defined solely by the terms of the written contract. Instead, the actual transaction should be determined from the conduct of the parties, leading to the conclusion that the actual functions performed, assets used, and risks assumed by the parties are not consistent with the written license agreement.

- (d) TEI singled out this example in its comments on an earlier discussion draft. TEI said the P-S license should not be ignored, or treated as though it does not recognize the parties "actual transaction." P's assistance to S obviously is in the interest of P since P receives a royalty from S, presumably based on S's gross revenue. Thus, there are countervailing considerations that might lead P to act in the manner described in the example that should be taken into account. Analyzing the conduct of the parties can be difficult, stated TEI, and thus can be subject to different interpretations and views, much more so than the written agreements that underlie the contractual arrangements. TEI stated that the economic analysis should not downplay the importance of contracts. Nonetheless, the example was included in the final revisions to the Transfer Pricing Guidelines.
- (e) The new the Transfer Pricing Guidelines continue by stating that compensation usually will reflect the functions that each enterprise performs (taking into account assets used and risks assumed). However, the actual contributions, capabilities, and other features

of the parties also can influence the options realistically available to them.

4. Risk.

- (a) A functional analysis is incomplete unless the material risks assumed by each party have been identified and considered since the actual assumption of risks would influence the prices and other conditions of transactions between associated enterprises. The assumption of risks associated with a commercial opportunity affects the profit potential of that opportunity in the open market, and the allocation of risks assumed between parties to the arrangement reflects how profits and losses resulting from transactions are allocated at arm's length through a transfer pricing analysis.
- (b) The new guidelines state that the steps in the process for analyzing risk in a controlled transaction can be summarized as follows:
  - (1) identify economically significant risks with specificity;
  - (2) determine how specific, economically significant risks are contractually assumed by the associated enterprises under the terms of the transaction;
  - (3) determine through a functional analysis how the associated enterprises that are parties to the transaction operate in relation to the assumption and management of the specific, economically significant risks, and in particular which enterprise or enterprises perform controlled functions and risk mitigation functions, which enterprise or enterprises encounter upside or downside consequences of risk outcomes, and which enterprise or enterprises have the financial capacity to assume the risk; and
  - (4) interpret the information and determine whether the contractual assumption of risk is consistent with the conduct of the associated enterprises and other facts of the case by analyzing
    - (a) whether the associated enterprises follow the contractual terms under the principles of the new guidelines and
    - (b) whether the party assuming risk exercises control over the risk and has the financial capacity to assume the risk.
- (c) Risk management is not the same as assuming a risk. Risk assumption means taking on the upside and downside consequences of the risk with the result that the party assuming a risk will also bear the financial and other consequences if the risk materializes.
- (d) Financial capacity to assume risk can be defined as access to funding to take on the risk or layoff the risk, to pay for the risk mitigation functions and to bear the consequences of the risk if the risk materializes.

- (e) Control over risk involves the first of two elements of risk management, that is (1) the capability to make decisions to take on, layoff, or decline a risk-bearing opportunity, together with the actual performance of that decision-making function and (2) the capability to make decisions on whether and how to respond to the risks associated with the opportunity, together with the actual performance of that decision-making function. Day-to-day mitigation is not necessary to have control of the risks. However, where these day-to-day mitigation activities are outsourced, control of the risk would require capability to determine the objectives of the outsourced activities, to decide to hire the provider of the risk mitigation functions and related matters.
- (f) Risks can be categorized in various ways, but a relevant framework in a transfer pricing analysis is to consider the source of uncertainty that gives rise to risk. Risk can involve strategic risks or marketplace risks, infrastructure or operational risks, financial risks, transactional risks and hazard risks.
- (g) Two examples illustrate risk:

In the first situation, the multinational group distributes heating oil to consumers. Analysis of the economically relevant characteristics establishes that the product is undifferentiated, the market is competitive, the market size is predictable, and players are price-takers. In these circumstances, the ability to influence margins may be limited. The credit terms achieved from managing the relationship with the oil suppliers fund working capital and are crucial to the distributor's margin. The impact of the risk on cost of capital is, therefore, significant in the context of how value is created for the distribution function.

In the second situation, a multinational toy retailer buys a wide range of products from a number of third-party manufacturers. Most of its sales are concentrated in the last two months of the calendar year, and a significant risk relates to the strategic direction of the buying function, and in making the right bets on trends and determining the products that will sell and in what volumes. Trends and the demand for products can vary across markets, and so expertise is needed to evaluate the right bets in the local markets. The effect of the buying risk can be magnified if the retailer negotiates a period of exclusivity for a particular product with the third-party manufacturer.

- (h) Other examples include development risk, capacity utilization and supply chain risk, and utilization of an intangible asset which

presents the risk that there will be insufficient demand for the asset to cover the costs involved.

- (i) The guidelines state that when two or more parties to a transaction assume a specific risk, and in addition, they together control the specific risk and each has the financial capacity to assume their share of the risk, that assumption of risk should be respected. Examples may include the contractual assumption of development risk in a transaction in which the enterprises agree jointly to bear the risks of creating a new product.

5. Economic Circumstances. Economic circumstances that may be relevant to determining market comparability include the geographic region, the size of markets, the extent of competition in the markets and the relative competitive positions of the buyers and the sellers, the availability (risk thereof) of substitute goods and services, the levels of supply and demand in the market as a whole, consumer purchasing power, the nature and extent of government regulation of the market, cost of production, the cost of land, transportation costs, the level of the market, and so forth. The existence of a cycle, such as an economic, business or product cycle, is one of the economic circumstances that should be identified.

6. Business Strategies. Business strategies could include market penetration plans. A taxpayer seeking to penetrate a market or to increase its market share might temporarily charge a price for its product that is lower than the price charged for otherwise comparable products in the same market. Business strategies such as those involving market penetration or expansion of market share involve reductions in the taxpayer's current profits in anticipation of increased future profits.

7. Accurately Delineating the Transaction.

- (a) The transfer pricing analysis at this point will have identified the substance of the commercial or financial relation between the parties and will have accurately delineated the actual transaction by analyzing the economically relevant characteristics. The next analysis involves determining the circumstances in which the transaction between the parties has accurately delineated can be disregarded for transfer pricing purposes. Disregarding the transaction between the parties can be contentious and thus a source of double taxation. Thus, every effort should be made to determine the actual nature of the transaction and apply arm's length pricing to the accurately delineated transaction, and to ensure that non-recognition of the transaction as structured is not used simply because determining an arm's length price is difficult.

- (b) The key question in the analysis is whether the actual transaction possesses the *commercial rationality* of arrangements that would be agreed between unrelated parties under comparable economic circumstances, not whether the transaction can be observed between independent parties. The non-recognition of a transaction that possesses commercial rationality of an arm's length arrangement is not an appropriate application of the arm's length principle.
- (c) The guidelines set forth two examples:

In the first example, Company S1 carries on a manufacturing business that involves holding substantial inventory and a significant investment in plant and machinery. It owns commercial property situated in an area prone to increasingly frequent flooding in recent years. Third-party insurers experience significant uncertainty over the exposure to large claims, with the result that there is no active market for insurance of properties in the area. Company S2, an associated enterprise, provides insurance to Company S1, and an annual premium representing 80% of the value of the inventory, property and content is paid by Company S1. In this example, S1 has entered into a commercially irrational transaction since there is no market for insurance given the likelihood of significant claims. The transaction should not be recognized.

In the second example, Company S1 conducts research activities to develop intangibles that it uses to create new products that it can produce and sell. It agrees to transfer to an associated company, Company S2, unlimited rights to all future intangibles which may arise from its future work over a period of 20 years for a lump-sum payment. The arrangement is commercially irrational for both companies since neither Company S1 nor Company S2 has any reliable means to determine whether the payment reflects an appropriate valuation, both because it is uncertain what range of development activities Company S1 might conduct over the period and also because valuing the potential outcomes would be entirely speculative. The arrangement adopted by the taxpayer, including the form of the payment should be modified for purposes of the transfer pricing analysis.

## 8. Location Savings and Other Local Market Features.

- (a) Location savings and other market features can be important in the analysis. Determining how location savings are to be shared between two or more associated enterprises requires considering (1) whether location savings exists, (2) the amount of any location



savings, (3) the extent to which location savings are either retained by a member or members of the multinational group or are passed on to independent customers or suppliers, and (4) where location savings are not fully passed on to independent customers or suppliers, the manner in which independent enterprise is operating under similar circumstances would allocate any retained location savings.

- (b) Features of the local market in which the business operates may affect the arm's length price with respect to transactions between associated enterprises. For example, the comparability and functional analysis conducted with a particular matter may suggest that the relevant characteristics of the geographic market in which the products are manufactured or sold, the purchasing power and product preferences of households in that market, whether the market is expanding or contracting, the degree of competition in the market and other similar factors affect prices and margins that can be realized in the market. It is important to distinguish between features of the local market, which are not intangibles, and any contract rights, government licenses, or know-how necessary to exploit that market, which may be intangibles.

9. Assembled Workforce.

- (a) Some businesses are successful in assembling a uniquely qualified or experienced cadre of employees. The existence of such an employee group may affect the arm's length price for services provided by the employee group or the efficiency with which the services are provided or goods produced by the enterprise. In some business restructurings and similar transactions, an assembled workforce might be transferred from one associated enterprise to another as a part of the transaction. It may be appropriate to reflect the time and expense savings in the form of comparability adjustments to the arm's length price otherwise charged for the transferred assets.
- (b) This is not to suggest that transfers or secondments of individual employees between members of a multinational group should be separately compensated as a general matter. In some situations, however, the transfer or secondment of one or more employees may, depending on the facts and circumstances, result in the transfer of valuable know-how or other intangibles from one associated enterprise to another.

10. Group Synergies.

- (a) Comparability issues, and a need for comparability adjustments, can also arise because of the existence of group synergies. Group synergies are often favorable to the group as a whole and therefore may heighten the aggregate profits earned by group members, depending on whether expected cost savings are, in fact, realized, and on competitive conditions. An associated enterprise should not be considered to receive an intra-group service or be required to make any payment when it obtains incidental benefits attributable solely to being part of a larger group. The term incidental refers to benefits arising solely by virtue of group affiliation and in the absence of deliberate concerted actions or transactions leading to that benefit.
- (b) In some circumstances, however, synergistic benefits and burdens of group membership may rise because of deliberate concerted group actions and may give a multinational group a material, clearly identifiable structural advantage or disadvantage in the marketplace over market participants that are not part of a multinational group.
- (c) Two of the examples follow:

In the first example, Company A is assigned to the role of central purchasing manager on behalf of the entire multinational group. It purchases from independent suppliers and resells to associated enterprises. Company A, based solely on the negotiating leverage provided by the purchasing power of the entire group is able to negotiate with a supplier to reduce the price of widgets from \$200 to \$110. Under these circumstances, the arm's length price for the resale of widgets by Company A to other members of the group would not be at all near \$200. Instead, the arm's length price would remunerate Company A for its services of coordinating the purchasing activity. If the comparability and functional analysis suggests in this case that in comparable uncontrolled transactions involving a comparable volume of purchases, comparable coordination services resulted in a service fee based on Company A's costs incurred plus a mark-up equating to a total service fee of \$6 per widget, then the intercompany price for the resales of the widgets would be approximately \$116.

In a second example, Company A negotiates the discount on behalf of the group and group members subsequently purchase the widgets directly from the independent supplier. Under these circumstances, assume that the comparability analysis suggests that Company A

would be entitled to a service fee of \$5 per widget for coordinating services that are performed on behalf of the other group members. The lower assumed service fee may reflect a lower level of risk in the service provider following from the fact that it does not take title to the widgets or hold inventory. Group members purchasing widgets would retain the benefit of the group purchasing discount attributable to their individual purchases after payment of the service fee to Company A.

B. Intangibles.

1. Chapter VI of the Transfer Pricing Guidelines also would be replaced with a new descriptive analysis. Chapter VI is the important chapter on intangibles.
2. Difficulties can arise in a transfer pricing analysis as a result of definitions of the term intangible that are either too narrow or too broad. In the new guidelines, the word “intangible,” is intended to address something that is not a physical asset or a financial asset, which is capable of being owned or controlled for use in commercial activities, and whose transfer would be compensated had it occurred in a transaction between independent parties in comparable circumstances.
3. The availability and extent of legal, contractual or other forms of protection may affect the value of an item and the returns that should be attributed to it. This existence of this protection is not, however, a necessary condition for an item to be characterized as an intangible for transfer pricing purposes. Similarly, while some intangibles may be identified separately and transferred on a segregated basis, other intangibles may be transferred only in combination with other assets. Therefore, separate transferability is not a necessary condition for an item to be characterized as an intangible for transfer pricing purposes.
4. It is important to distinguish intangibles from market conditions or local market circumstances. Features of a local market, such as the level of disposable income of households in that market or the size or relative competitiveness of the market are not capable of being owned or controlled. While in some circumstances they may affect the determination of an arm’s length price for a particular transaction and should be taken into account, they are not intangibles for purposes of Chapter VI.
5. Illustrations of intangibles include patents, know-how and trade secrets, and trademarks, trade names and brands.
6. Depending on the context, the term goodwill can be used to refer to a number of different concepts. In some accounting and business valuation

contexts, goodwill refers to the difference between the aggregate value of an operating business and the sum of the values of all separately identifiable tangible and intangible assets. Alternatively, goodwill is sometimes described as a representation of the future economic benefits associated with business assets that are not individually identified and separately recognized. It is generally recognized that goodwill and going concern value cannot be segregated or transferred separately from other business assets.

7. It is not necessary to establish a precise definition of goodwill or going concern value for transfer pricing purposes or define when goodwill or going concern value may or may not constitute an intangible. It is important to recognize, however, that an important and monetarily significant part of the compensation paid between independent enterprises when some or all of the assets of an operating business are transferred may represent compensation for something referred to in one or another of the alternative descriptions of goodwill or going concern value.
8. Group synergies and market specific characteristics are not owned or controlled by the enterprise and therefore are not intangibles within the meaning of Chapter VI.
9. Legal rights and contractual arrangements form the starting point for any transfer pricing analysis of transactions involving intangibles. The terms of a transaction may be found in written contracts, public records such as patent or trademark registrations, or in correspondence and/or other communications among the parties.
10. When no written terms exist, or where the facts of the case, including the conduct of the parties, differ from the written terms of any agreement between them or supplement these written terms, the actual transaction may be deduced from the facts established, including the conduct of the parties.
11. The legal owner will be considered to be the owner of the intangible for transfer pricing purposes. If no legal owner of the intangible is identified under the applicable law or governing contracts, then the member of the multinational group that, based on the facts and circumstances, controls decisions regarding the exploitation of the intangible and has the practical capacity to restrict others from using the intangible will be considered the legal owner of the intangible for transfer pricing purposes.
12. While determining legal ownership and contractual arrangements is an important first step in the analysis, these determinations are separate and distinct from the question of remuneration under the arm's length principal. For transfer pricing purposes, legal ownership of intangibles, by itself, does not confer any right ultimately to retain returns derived by the

multinational group from exploiting the intangible, even though the returns may initially accrue to the legal owner as a result of its legal or contractual right to exploit the intangible. The return ultimately retained by or attributed to the legal owner depends on the functions it performs, the assets it uses and the risks it assumes, and upon the contributions made by other multinational group members through their functions performed, assets used and risks assumed.

13. Because the actual outcome and manner in which risks associated with the development or acquisition of an intangible will play out over time are not known with certainty at the time members of the multinational group make decisions regarding intangibles, it is important to distinguish between (a) anticipated (or *ex ante*) remuneration, which refers to the future income expected to be derived by a member of the multinational group at the time of a transaction; and (b) actual (or *ex post*) remuneration, which refers to the income actually earned by a member of the group through the exploitation of the intangible.
14. The terms of the compensation that must be paid to members of the multinational group that contribute to the development, enhancement, maintenance, protection and exploitation of intangibles is generally determined on an *ex ante* basis. That is, it is determined at the time the transactions are entered into and before risks associated with the intangible play out. The form of the compensation may be fixed or contingent. The actual (*ex post*) profit or loss of the business after compensating other members of the multinational group may differ from these anticipated profits depending on how the risks associated with the intangible or the other relevant risks related to the transaction actually play out.
15. Each member of the multinational group should receive arm's length compensation for the functions it performs. In cases involving intangibles, this includes functions related to the development, enhancement, maintenance, protection and exploitation of intangibles. The identity of the member or members of the group performing functions related to the development, enhancement, maintenance, protection and exploitation of intangibles, therefore, is one of the key considerations in determining the arm's length consideration for controlled transactions.
16. When associated enterprises other than the legal owner perform relevant functions that are anticipated to contribute to the value of the intangibles, they should be compensated on an arm's length basis for the functions they perform under general transfer pricing principles. If the legal owner neither controls nor performs a function related to the development, enhancement, maintenance, protection or exploitation of the intangible, the legal owner would not be entitled to any ongoing benefit attributable to the outsourced functions.

17. Particular types of risk that may have importance in a functional analysis relating to transactions involving intangibles include (1) risks related to development of intangibles, including the risk that costly research and development of marketing activities will prove to be unsuccessful, and taking into account the timing of the investment; (2) the risk of product obsolescence, including the possibility that technological advances of competitors will adversely affect the value of the intangibles; (3) infringement risk, including the risk that defense of intangible rights or defense against other persons' claims of infringement may prove to be time consuming, costly and/or unavailing; (4) product liability and similar risks related to products and services based on the intangibles; and (5) exploitation risks, uncertainties in relation to the returns to be generated by the intangible.
18. It is especially important to ensure that the group members asserting entitlement to returns from assuming risk actually bear responsibility for the actions that need to be taken and the cost that may be incurred if the relevant risk materializes.
19. The guidelines state that it is quite common that actual (*ex post*) profitability is different from anticipated (*ex ante*) profitability. This may happen because a profitable product is removed from the market. It may result from risks materializing in a different way from what was anticipated through the occurrence of unforeseeable developments. The financial projections on which the calculations of *ex ante* returns and the compensation arrangements are based may properly have taken into account risks and the probability of reasonably foreseeable events occurring and that the differences between actual and anticipated profitability reflects the playing out of those risks. On the other hand, the financial projections on which the calculations of the *ex ante* returns and the compensation arrangements were based might not have adequately taken into account the risks of different outcomes.
20. Resolution of this question requires a careful analysis of which entity or entities in the multinational group in fact assume the economically and significant risks identified when delineating the actual transaction. The party actually assuming the economically significant risks may or may not be the associated enterprise contractually assuming those risks. A party that is not allocated the risks that caused the anticipated and actual outcomes will not be entitled to the differences between the actual and anticipated profits or required to bear the losses that are caused by these differences if the risk materializes, unless these parties are performing the important functions or contributing to the control of the economically significant risks.
21. If the legal owner of an intangible in substance (1) performs and controls all of the functions related to the development, enhancement, maintenance,

protection and exploitation of the intangibles; (2) provides all assets, including funding, necessary to the development, enhancement, maintenance, protection and exploitation of the intangibles; and (3) assumes all of the risks related to the development, enhancement, maintenance, protection and exploitation of the intangible, then it will be entitled to all of the anticipated (*ex ante*) returns derived from the multinational group's exploitation of the intangible.

22. A common situation regarding marketing intangibles arises when an enterprise associated with the legal owner of trademarks performs marketing or sales functions that benefit the legal owner of the trademark, for example, through a marketing arrangement or through a distribution/marketing arrangement. In these cases, it is necessary to determine how the marketer or distributor should be compensated for its activities. One important issue is whether the marketer/distributor should be compensated only for providing promotion and distribution services, or whether the marketer/distributor should also be compensated for enhancing the value of the trademarks and other marketing intangibles by virtue of its functions, assets and risks assumed.
23. Questions often arise regarding the arm's length compensation for the use of group names, trade names and similar intangibles. Resolution of these questions should be based on general transfer pricing principles and on the commercial and legal factors involved. As a general rule, no payment should be recognized for transfer pricing purposes for simple recognition of group membership or the use of the group name merely to reflect the fact of group membership.
24. When one member of the group is the owner of a trademark or other intangible with a group name, and where use of the name provides a financial benefit to members of the group other than the member legally owning the intangible, it is reasonable to conclude that a payment for use would have been made in an arm's length transaction. Similarly, these payments may be appropriate when a group member owns goodwill in respect of the business represented by an unregistered trademark, use of that trademark by another party would constitute misrepresentation, and the use of the trademark provides a clear financial benefit to a group member other than the one that owns the goodwill and unregistered trademark.
25. Sales of Goods.
  - (a) Intangibles may be used in connection with controlled transactions in situations where there is no transfer of the intangible or of rights in the intangible. For example, intangibles may be used by one or both parties to a controlled transaction in connection with the manufacture of goods sold to an associated enterprise, in

connection with the marketing of goods purchased from an associated enterprise, or in connection with the performance of services on behalf of an associated enterprise.

- (b) The need to consider the use of intangibles by a party to a controlled transaction involving a sale of goods can be illustrated as follows:

Assume that a car manufacturer uses valuable proprietary patents to manufacture the cars that it then sells to associated distributors. Assume the patents significantly contribute to the value of the cars. The patents and the value they contribute should be identified and taken into account in the comparability analysis of the transaction consisting of the sales of cars by the car manufacturer to its associated distributors, in selecting the most appropriate transfer pricing method for the transactions, and in selecting the tested party. The associated distributors purchasing the cars do not, however, acquire and right in the manufacturer's patents. In such a case, the patents are used in the manufacturing and may affect the value of the cars, but the patents themselves are not transferred.

- (c) Many intangibles have a limited useful life. The useful life of a particular intangible can be affected by the nature and duration of the legal protection afforded to the intangible. The useful life of some intangibles also can be affected by the rate of technological change in an industry and by development of new and potentially improved products. Sometimes, the useful life of a particular intangible can be extended.
- (d) In conducting a comparability analysis, it is important to consider the expected useful life of the intangibles in question. In general, intangibles expected to provide market advantages for a longer period of time will be more valuable than similar intangibles providing these advantages for a shorter period of time, other things being equal. In evaluating the useful life of intangibles it is also important to consider the use being made of the intangible. The useful life of an intangible that forms a base for ongoing research and development may extend beyond the commercial life of the current generation product line based on that intangible.
- (e) The guidelines discuss application of transactional profit split methods and state that caution should be exercised in applying profit split approaches to determine estimates of the contributions of the parties to the creation of income in the years following the transfer.



- (f) The guidelines also discuss specific areas of concern in applying methods based on the discounted value of projected cash flows. The guidelines state the reliability of the intangible value produced using a valuation model is particularly sensitive to the reliability of the underlying assumptions and estimates on which it is based. There is no single measure for a discount rate that is appropriate for transfer pricing purposes in all cases.

26. Hard-To-Value Intangibles.<sup>6</sup>

- (a) In dealing with hard-to-value intangibles, a tax administration may find it difficult to establish or verify what developments or events might be considered relevant for the pricing of a transaction involving the transfer of intangibles or rights in intangibles, and the extent to which the occurrences of these developments or events, or the direction they take, might have been foreseeable or reasonably foreseeable at the time the transaction was entered into.
- (b) In these situations, *ex post* outcomes can provide a pointer to tax administrations about the arm's length nature of the *ex ante* pricing arrangement agreed upon by the associated enterprises, and the existence of uncertainties at the time of the transaction. If there are differences between the *ex ante* projections and the *ex post* results that are not due to unforeseeable developments or events, the differences may give an indication that the pricing arrangement agreed upon by the associated enterprises at the time the transaction was entered into may not have adequately taken into account the relevant developments or events that might have been expected to affect the value of the intangible and the pricing arrangements adopted.
- (c) The guidelines contain an approach consistent with the arm's length principle that tax administrators can adopt to ensure that they can determine in which situations the pricing arrangements used by taxpayers are at arm's length and are based on an appropriate weighting of the foreseeable developments or events that are relevant for the valuation of certain hard-to-value intangibles, and in which situations this is not the case.
- (d) Under this approach, *ex post* evidence provides presumptive evidence as to the existence of uncertainties at the time of the transaction, whether the taxpayer appropriately took into account reasonably foreseeable developments or events at the time of the

---

<sup>6</sup> The Hard-to-Value Intangibles area will be the subject of follow up that Working Party 6 will do in 2016-7 to more fully develop certain aspects of these rules. This will not hold up adoption of the BEPS Final Reports, however.

transaction, and the reliability of the information used *ex ante* in determining the transfer price for the transfer of the intangibles or rights in the intangibles.

- (e) This presumptive evidence may be subject to rebuttable if it can be demonstrated that it does not affect the accurate determination of the arm's length price. This situation should be distinguished from a situation in which hindsight is used by taking *ex post* results for tax assessment purposes without considering whether the information on which the *ex post* results are based could or should reasonably have been known and considered by the associated enterprises at the time the transaction was entered into.
- (f) Thus, a tax administrator can consider *ex post* outcomes as presumptive evidence about the appropriateness of the *ex ante* pricing but the consideration of *ex post* evidence should be based on a determination that the evidence is necessary to assess the reliability of the information on which the *ex ante* pricing was based.
- (g) This approach will not apply to transactions involving the transfer of hard-to-value intangibles when at least one of the following exceptions applies.
  - i. The taxpayer provides: (a) details of the *ex ante* projections used at the time of the transfer to determine the pricing arrangements, including how risks were accounted for in the calculations of determining the price, and the appropriateness of its consideration of reasonably foreseeable events and other risks, and the probability of occurrence; and (b) reliable evidence that any significant difference between the financial projections and actual outcomes is due to unforeseeable developments or events occurring after the determination of the price that could not have been anticipated by the associated enterprises at the time of the transaction or the playing out of the probability of occurrence of foreseeable outcomes and that these probabilities were not significantly overestimated or underestimated at the time of the transaction;
  - ii. The transfer of the hard-to-value intangible is covered by a bilateral or multilateral advance pricing agreement in effect for the period in question between the countries of the transferee and transferor.
  - iii. Any significant difference between the financial projections and actual outcomes mentioned above does not have the

effect of reducing or increasing the compensation for the hard-to-value intangible by more than 20% of the compensation determined at the time of the transaction.

- iv. A commercialization period of five years has past following the year in which the hard-to-value intangible first generated unrelated party revenues for the transferee and in which commercialization period any significant difference between the financial projections and the actual outcomes was not greater than 20% of the projections for that period.
- (h) TEI submitted comments on the earlier discussion draft addressing hard-to-value intangibles. The discussion draft assumed that independent enterprises are able to renegotiate agreements if major unforeseen developments occur. In TEI's experience, such renegotiations are extremely rare, and even a "repricing" of some sort or after-the-fact review of contract terms is not common in contracts between unrelated parties. TEI stated that agreements may be structured to minimize the business risks of a "bad deal," such as a shorter contract term, or through the use of a price adjustment or contingent payment mechanism based on meeting certain milestones. Needless to say, however, stated TEI, in contracts between unrelated parties these terms are set at the outset of the contract through negotiations using only before-the-fact information.
- (i) Twenty-nine examples illustrate the guidance on intangibles and are set forth in an annex to revised Chapter VI.
- (j) Examples 1-5 utilize the same or a similar fact pattern. P is the parent of the multinational group and S is a wholly owned subsidiary. P funds R&D programs and performs ongoing R&D functions in support of its business operations. When its R&D functions result in patentable inventions, it is the practice of the P group that all rights and the inventions be assigned to S in order to centralize and simplify global patent administration. All patent registrations are held and maintained in the name of S.
- (k) P performs all functions related to the development, enhancement, maintenance, protection and exploitation of the intangibles except for patent administration services. The actual transaction undertaken between P and S could be described as a patent administration service arrangement. An arm's length price would be determined based on patent administration services.

- (l) In Example 2, the facts are the same except that S, acting under the direction and control of P, grants licenses of its patent to associated and independent enterprises throughout the world for periodic royalties. S is the legal owner of the patents. However, S employees do not control or participate in the licensing transactions involving the patents, and its three employees are limited to the activities of registering the patents and maintaining patent registrations.
- (m) As in Example 1, the true nature of the arrangement is a patent administration service arrangements. The compensation due to P for the patentable inventions is equal to the licensing revenue of S less an appropriate return for the functions S performs.
- (n) In Example 3, the facts are the same as in Example 2 except that S, again acting under the direction and control of P, sells the patents to an independent enterprise reflecting the appreciation and value of the patents. Under these circumstances, the income of S should be the same as in Example 2.
- (o) In Example 4, the facts are the same as in Example 3 except that S has employees capable of making, and who actually make, the decision to take on the patent portfolio. All decisions relating to the licensing program are made by S employees, all negotiations with licenses are handled by S employees and S employees monitor compliance of independent licensees with the terms of the patents. It is assumed for purposes of the example that the initial price paid by S in exchange for the patents was an arm's length price. It also is assumed that the approach for hard-to-value intangibles does not apply. Further, the value of the patents increased significantly because of external circumstances unforeseen at the time the patents were assigned to S. Under these circumstances, S is entitled to retain the proceeds of the sale, including amounts attributable to the appreciation in value of the patents resulting from unanticipated external circumstances.
- (p) In Example 5, the facts are the same as in Example 4 except that instead of appreciating, the value of the patents decreases during the time they are owned by S as a result of unanticipated external circumstances. S is entitled to retain the proceeds of sale, meaning that it will suffer the loss.
- (q) In Example 6, a multinational group comprised of A and B decides to develop an intangible that is anticipated to be highly profitable based on B's existing intangibles, its track record and its experienced R&D staff. Development will take five years and the intangible is anticipated to have value for 10 years. B will perform

and control all activities related to development, enhancement, maintenance, protection and exploitation of the intangible.

- (r) A will provide all funding associated with development of the intangible and will become the legal owner of the intangible once developed. A will license the intangible to B for contingent payments.
- (s) A functional analysis determines that the actual transaction is that, although A is the legal owner of the intangibles, its contribution to the arrangement is solely funding for the development of the intangible. A contractually assumes financial risk, has the financial capacity to assume that risk, and exercises control over that risk. Thus, A's anticipated remuneration should be its risk-adjusted return on its funding commitment. B, accordingly, would be entitled to all remaining anticipated income after accounting for A's anticipated return.
- (t) Example 7 describes P, a pharmaceutical company, and S, its subsidiary that distributes product throughout Europe and the Middle East on a limited risk basis. In the first three years of operation, S earns returns from its distribution function that are consistent with its limited risk characterization. After three years, the product involved causes serious side effects and S incurs substantial costs in connection with a recall. P does not reimburse S for these recall-related costs or the resulting product liability claims.
- (u) Under these circumstances, there is an inconsistency between P's asserted entitlement to returns derived from exploiting the product and its failure to bear costs associated with the risks supporting that assertion. If it is determined that the true nature of the relationship is that S is a limited risk distributor, then the most appropriate adjustment would be in the form of an allocation of the recall costs from S to P. Alternatively, although unlikely, if it is determined on the basis of the facts that the true nature of the relationship includes the exercising of control over product liability and recall by S, and if an arm's length price can be based on the basis of a comparability analysis, an increase in distribution margins of S for all years might be made.
- (v) Examples 8-13 are based on the same general fact pattern. Example 8 involves P, a manufacturer of watches marketed in countries around the world utilizing P's name, which is widely known. P decides to enter the Country Y market and incorporates S, a new subsidiary there to act as a distributor. P enters into a long-term royalty-free marketing and distribution agreement with

S. Under the contract, S purchases the watches from P, takes title and performs distribution functions. P incurs associated carrying costs, and so forth. P develops the overall marketing plan, and S assists in developing the market. S consults on local market issues related to advertising. S receives a service fee from P.

- (w) Assume that it is possible to conclude that the price S pays P for the watches should be analyzed separately from the compensation S receives for the marketing it undertakes on behalf of P. Assume further that the price paid for the watches is arm's length.
- (x) S embarks on a strategy consistent with its agreement with P to develop the Y market. S is reimbursed by P for marketing expenses, and is paid a markup. By the end of year 2, the trademark and trade name have become well established in Country Y.
- (y) Under these circumstances, P is entitled to retain any income derived from exploiting the trademark and trade name in the Country Y market that exceeds the arm's length compensation to S for its functions and no transfer pricing adjustment is warranted under the circumstances.
- (z) In Example 9, S is now obligated to develop and execute the marketing plan without detailed control of specific elements by P. S receives no direct reimbursement from P, which exercises a lower level of control over marketing activities of S. As a result of these differences, P and S adopt a price for the watches lower than in Example 9.
- (aa) Given that Company S performs functions and bears the costs of associated risks of its marketing activities under a long-term contract of exclusive distribution rights for the watches, there is an opportunity for S to benefit (or suffer a loss) from the marketing and distribution activities it undertakes. These activities are similar to those of independent marketers and distributors and comparable uncontrolled transactions. S's return reflects arms-length consideration for S's contributions and accurately measures a share of the income derived from exploitation of the trademark and trade name in Country Y.
- (bb) In Example 10, the facts are the same as in Example 9, except that the market development functions undertaken by S are far more extensive than those undertaken by S in Example 9. The level of marketing expense S incurs in Years 1 through 5 exceeds that incurred by identified comparable independent marketers and distributors. P and S expect those additional functions to generate

higher margins or increased sales volume for the products. Thus S has made a larger functional contribution to development of the market and the marketing intangibles and has assumed significantly greater costs and assumed greater risks than previously identified.

- (cc) Based on these facts, it is evident that by performing functions and incurring marketing expenditures substantially in excess of the levels of function and expenditures of independent marketers/distributors in comparable transactions, S has not been adequately compensated by the margins it earns on re-sale of the watches. It would be appropriate for the Country Y tax administration to propose a transfer pricing adjustment. This could be based on reducing the price paid by S for the watches, applying a residual profit split that would split the combined profits by first giving P and S a basic return for their functions and then splitting the residual profit on a basis that takes into account the residual contributions of P and S, or directly compensating S for the excess marketing expenditure that it has incurred over and above that incurred by comparable independent enterprises.
- (dd) In Example 11, the facts are the same as in Example 9, except that S enters into a three-year royalty-free agreement to market and distribute the watches in the Country Y market, with no option to renew. At the end of the three-year period, S does not enter into a new contract with P. The evidence derived from comparable independent enterprises shows that they do not invest large sums of money in developing marketing and distribution infrastructure where they obtain only a short-term marketing and distribution agreement, with the attendant risk of non-renewal without compensation. Thus, S could not, or may not, be able to benefit from the marketing and distribution expenditure that it incurs at its own risk.
- (ee) In this case, S has undertaken market development activities and borne marketing expenditures beyond what comparable independent enterprises with similar rights would incur for their own benefit. S is entitled to compensation for its at-risk contribution to the value of the trademark and trade name during the term of its agreement with P.
- (ff) Example 12 is based on the same facts except that at the end of Year 3, P and S renegotiate their earlier agreement and enter into a new long-term licensing agreement. S agrees to pay a royalty to P based on gross sales of all watches bearing the trademark. Assume there is no evidence that independent marketers or distributors of similar products have agreed to pay royalties under similar

circumstances. For transfer pricing purposes it would not generally be expected that a royalty would be paid where a marketing and distribution entity obtains no rights for transfer pricing purposes in trademarks and similar intangibles, other than the right to use the intangibles in distributing branded product supplied by P. Namely, a transfer pricing adjustment disallowing the royalties paid as a deduction would be appropriate.

- (gg) Example 13 is similar except that at the end of Year 3, P stops manufacturing watches and contracts with a third party to manufacture them on its behalf. As a result, S will import unbranded watches directly from the manufacturer and undertake secondary processing to apply the trade name and logo and package the watches before sale to the final customer. As a consequence, at the beginning of Year 4, P and S re-negotiate their earlier agreement and enter into a new long-term licensing agreement. S is granted exclusive rights within Country Y to process, market and distribute watches bearing the R trademark. S pays a royalty to P.
- (hh) The Country Y tax administration determines, based on a functional analysis, that the level of marketing expenses S incurred during Years 1 through 3 far exceeded those incurred by independent marketers and distributors with similar long-term marketing and distribution agreements. It is also determined that the level and intensity of marketing activity undertaken by S exceeded that of independent marketers and distributors.
- (ii) The Country Y audit also identifies that in Years 4 and 5, S bears the cost and associated risks of its marketing activities under the new long-term licensing agreement with P. Based on these facts, S should be compensated with an additional return for the market development functions it performs, the assets it uses and the risks it assumes. For Years 1 through 3, the possible bases for such an adjustment would be as described in Example 10. For Years 4 and 5, the bases for an adjustment would be similar, except that the adjustment could reduce the royalty payments from S to P, rather than the purchase price of the watches.
- (jj) Examples 14, 15 and 16 are based on a similar fact pattern. In Example 14, P is the parent of a multinational group that is involved in the purchase and sale of consumer goods. It operates an R&D center. Its subsidiary, S, also has an R&D operation. The P R&D center designs research programs, develops and controls budgets, makes decisions as to where R&D activities will be carried on, and so forth. The S R&D Center operation operates on a separate project basis to carry on specific projects assigned to it



by the P R&D Center. P establishes budgets and supervises the S R&D center. Contracts specify that the P R&D Center will bear all risks and costs related to R&D undertaken by S. All patents, designs and other intangibles developed by S are owned by P.

- (kk) P is entitled to earn compensation derived from the R&D. S should be paid for its services.
- (ll) Example 15 is similar, except that the S R&D Center performs its activities with respect to product line B, which is handled by S. The S R&D Center operates autonomously and its employees report to the Product Line B management team in S. P neither performs nor exercises control over the research function carried out by S.
- (mm) Even though P is the legal owner of the intangibles, this does not entitle P to retain or be attributed any income related to the Product Line B intangibles. S should not pay a royalty or make other payments to P for the right to use the successfully developed S intangibles. If P were to use them, P should pay a royalty to S.
- (nn) In Example 16, the facts are similar, except that P sells all rights to patents and other technology-related intangibles to a new subsidiary, T. T establishes a manufacturing facility in Country Z and begins to supply products to members of the P group around the world.
- (oo) It is assumed that the compensation paid by T in exchange for the transferred patents and related intangibles is based on evaluation of anticipated future cash flows generated by the transferred intangibles at the time of the transfer.
- (pp) T enters into a contract research agreement with P, and a separate contract research agreement with S. T contractually agrees to bear the financial risk associated with possible failure of future R&D projects, agrees to assume the costs of all future R&D activity, and agrees to pay P and S a service fee based on the costs of the R&D activities undertaken, plus a markup. T has no technical personnel capable of conducting or supervising the research activities. P and S continue to conduct R&D activities as in the past.
- (qq) T functions as a manufacturer and performs no activities in relation to the acquisition, development or exploitation of the intangibles and does not control risks in relation to the acquisition of the intangibles or contribute to their further development. Instead, all development activities and risk management functions relating to the intangibles are performed by P and S, with P controlling the

risks. As a result, in addition to its manufacturing reward, T is entitled to no more than a risk-free return for its funding activities.

- (rr) In Example 17, P is a fully integrated pharmaceutical company that transfers patents and related inventions related to Product M, an early-stage pharmaceutical preparation believed to have high potential value, to S. The price is based on evaluation of anticipated future cash flows. S has no technical personnel capable of designing, conducting or supervising required ongoing research activities. P continues to perform and control all functions and to manage risks related to the intangibles owned by S. S is entitled to a financing return.
- (ss) Example 18 describes P, which licenses patent invention and manufacturing know-how to S for use in Country B. S uses the patents and know-how to manufacture Product X in Country B and it sells the product to distribution entities based around Africa and Asia. The conduct of the parties suggests the transaction is a license for Country B plus Asia and Africa.
- (tt) Example 19 involves P with a unique marketing concept that is used by new subsidiary S. The example deems a license between the two.
- (uu) Example 20 involves the transfer of a business to a related company. The value of the business should include amounts that may be treated as the value of goodwill for accounting purposes.
- (vv) Example 21 involves the establishment of a re-invoicing company that performs no functions. Thus, it is not entitled to earn any income.
- (ww) Example 22 describes a government license for mining activity and a government license for the exploitation of a railway. An unrelated buyer pays \$100 for the business, including \$70 for goodwill based on synergies created between the mining and railway licenses. The buyer then transfers the mining and railway licenses to its subsidiary S. The goodwill associated with the licenses transferred to S would need to be considered, as it generally would be assumed that value does not disappear, nor is it destroyed, as a part of an internal business restructuring.
- (xx) In Example 23, P acquires 100% of the equity interests in an unrelated party, T, for \$100. T engages in R&D and has partially developed several promising technologies but has only minimal sales. The price for accounting purposes is treated as \$20 for tangible property and identified intangibles, including patents, and

\$80 for goodwill. Immediately following the acquisition, T transfers all of its rights in the partially developed technologies, including patents, trade secrets and technical know-how to S, a subsidiary of P. S enters into a contract research agreement with T, pursuant to which the T workforce will continue to work exclusively on the development of the transferred technologies and on the development of new technologies on behalf of Company S. It will be compensated on a cost-plus basis plus a markup. All rights to the intangibles will belong to S.

- (yy) The \$100 paid by P for the shares of T represents an arm's-length price for shares of the company. The full value of that business should be reflected either in the value of the tangible and intangible assets transferred to S or in the value of the tangible and intangible assets and workforce retained by T. Depending on the facts, a substantial portion of the value described in the purchase price allocation as goodwill of T may have transferred to S together with the other T intangibles. Some portion of the goodwill may also have been retained by T. T should be entitled to compensation for that value, either as a part of the price paid by S for the transferred rights to technology intangibles, or through the compensation T is paid in the years following the transaction for the R&D services of its workforce. It should generally be assumed that value does not disappear, nor is it destroyed, as a part of an internal restructuring.
- (zz) P engages in software development consulting in Example 24. In the past, P developed software supporting certain banking transactions. S, its subsidiary, enters into an agreement to develop software supporting operations for another bank (Bank B). P agrees to support S by providing employees who were involved with the previous project. Those employees have access to software designs and know-how developed by P. That software code and the services of the P employees are utilized by S in executing its Bank B engagement. For transfer pricing purposes, S has received two benefits from P which require compensation. First, it received services from the P employees who were made available to work on the Bank B engagement. Second, it received rights in P's proprietary software that was utilized as the foundation for the software system delivered to Bank B.
- (aaa) In Example 25, P has been involved in several large litigations. Its internal legal department had become adept at managing large-scale litigation. P also developed proprietary document management software tools unique to its industry. S, a subsidiary of P, becomes involved in complex litigation. P agrees to make two individuals from its legal team available to S to work on the S

litigation. It would not be appropriate to treat P as having transferred rights and intangibles to S. However, the fact that the P employees have experienced and available software tools that allowed them to more effectively and efficiently perform this service should be considered in a comparability analysis related to the amount of the service fees to be charged for the services of the P employees.

- (bbb) Example 26 describes an acquisition for \$160. P acquired S, a public company, whose market capitalization was \$100. P's management justified the \$160 purchase price in presentations to its board of directors by reference to the complementary nature of the existing products of the P group and the products and potential products of S. For accounting purposes, the purchase price was allocated \$90 to goodwill, with the rest going to tangible and intangible assets.
- (ccc) Immediately following the acquisition of S, P liquidates S and grants an exclusive and perpetual license to related company T for intangible rights related to the S products in European and Asian markets. In determining the arm's length price for the intangibles S licensed to T, the premium over the trading value of the S shares included in the acquisition price should be considered. To the extent the premium reflects the complementary nature of the P products with the acquired products licensed to Company T, T should pay an amount for the transferred S intangibles and rights to the intangibles that reflects an appropriate share of the purchase price premium. To the extent the purchase price premium is attributable exclusively to products outside of T's markets, the purchase price premium should not be taken into account.
- (ddd) In Example 27, P is the parent of the multinational group. S is a subsidiary that conducts operations in Country B. For sound business reasons related to the coordination of its group's patent protection, P decides to centralize ownership of the group's Product M patents in P. S sells its patents to P for a lump-sum price. P assumes responsibility to perform all ongoing functions and assumes all risks related to the patents following the sale.
- (eee) Valuation personnel apply a valuation method that directly values property and patents to arrive at an after-tax net present value for the patents of \$80. The analysis is based on royalty rates, discount rates, and useful lives typical in the industry in which Product M competes. However, there are material differences between the S patents and the relevant patent rights related to those products, and those typical in the industry. The valuation seeks to make adjustments for those differences.

- (fff) P also conducts a discounted cash flow-based analysis of the relevant business in its entirety. That analysis, based on valuation parameters typically used by P in evaluating potential acquisitions, suggests that the Product M business has a net present value of \$100. The \$20 difference between the \$100 valuation of the entire business and the \$80 valuation of the patents on their own appears to be inadequate to reflect the net present value of routine returns for functions performed by S and to recognize any value for the trademarks and know-how attained by S. Under these circumstances, further review of the reliability of the \$80 value ascribed to the patents would be called for.
- (ggg) Example 28 describes P, the parent of a multinational group with operations in Country S. For valid business reasons, the multinational group decides to centralize all its intangibles related to business conducted outside of Country S in a single location. Accordingly, intangibles owned by subsidiary B are sold to a related party, subsidiary C, for a lump-sum, including patents, trademarks, know-how and customer relationships. At the same time, C retains B as a contract manufacturer of products previously produced and sold by B on a full risk basis. C has the personnel and resources required to manage the acquired line of business, including the further development of intangibles necessary to the B business. The group is unable to identify comparable uncontrolled transactions that can be used in the transfer pricing analysis of the arm's length price to be paid by C to B. Valuation techniques are used. In conducting its valuation, the group is unable to reliably segregate particular cash flows associated with all of the specific intangibles.
- (hhh) Under these circumstances, in determining the arm's length compensation to be paid by C for the intangibles sold by B, it may be appropriate to value the transferred intangibles in the aggregate rather than attempt valuation on an asset-by-asset basis. This would particularly be the case if there is a significant difference between the sum of the best available estimates of the value of individually identified intangibles and other assets when valued separately and the value of the business as a whole.
- (iii) In Example 29, P transfers all of its production of Product F to newly-formed subsidiary S. P sells the patents and trademarks related to Product F to S for a lump-sum. P and S seek to identify an arm's length price for the transferred intangibles by utilizing a discounted cash flow valuation technique. According to this valuation analysis, P could have generated after-tax residual cash flows (after rewarding all functional activities of other members of the multinational group on an arm's length basis) having a present

value of \$600 by continuing to manufacture Product F in P's country. The valuation from the buyer's perspective shows that S could generate after-tax residual cash flows having a present value of \$1,100 if it owned the intangibles and manufactured the products in its country.

- (jjj) Another option open to P would be for P to retain ownership of the intangible, and to retain S or an alternative supplier to manufacture products on its behalf in S's country. In this scenario, P calculates it would be able to generate after-tax cash flows with a present value of \$875.
- (kkk) In defining the arm's length compensation for the intangibles transferred by P to S, it is important to take into account the perspectives of both parties, the options realistically available to each of them, and the particular facts and circumstances involved. P would certainly not sell the intangibles at a price that would yield an after-tax residual value with a present value lower than \$600, the residual cash flow it could generate by retaining the intangibles and continuing to operate in the manner that it has done historically. Moreover, there is no reason to believe P would sell the intangibles for a price that would yield an after-tax residual cash flow with the present value lower than \$850. If P could capture the production cost savings by retaining another entity to manufacture on its behalf in a low cost environment, one realistically available option to it would be to establish a contract manufacturing operation. This realistically available option should be taken into account in determining the selling price of the intangibles.
- (lll) S would not be expected to pay a price that would, after taking into account all relevant facts and circumstances, leave it with an after-tax return lower than it could achieve by not engaging in the transaction. According to the discounted cash flow valuation, the net present value of the after-tax residual cash flow it could generate using the intangible in its business would be \$1,100. A price might be negotiated that would give P a return equal to or greater than its other available options, and give S a positive return on its investment considering all the relevant facts, including the manner in which the transaction itself would be taxed.
- (mmm) A transfer pricing analysis utilizing a discounted cash flow approach would have to consider how independent enterprises dealing at arm's length would take into account the cost savings and projected tax effects in setting a price for the intangibles. That price should, however, fall in the range between a price that would yield P after-tax residual cash flow equivalent to that of its other

options realistically available, and a price that would yield S a positive return on its investments and risks, considering the manner in which the transaction itself would be taxed.

C. Low Value-Adding Intra-Group Services.

1. This section of the report introduces an elective, simplified approach for low value-adding services. It is responsive to Action 10 of the BEPS Action Plan regarding the development of transfer pricing rules to provide protection against common types of base eroding payments, such as management fees and head office expenses. The report makes some changes and clarifications in Chapter VII of the OECD's Transfer Pricing Guidelines. Sections A to C are changed to provide context to new section D on low value-adding intra-group services.
2. In section B, the benefits test is described as initially raising the question whether an intra-group service has been rendered when an activity is performed for one or more group members by another group member. The analysis should depend on whether the activity provides a respective group member with economic or commercial value to enhance or maintain its business position. This can be determined by considering whether an independent enterprise in comparable circumstances would have been willing to pay for the activity if performed for it by an independent enterprise or would have performed the activity in-house for itself. If the activity is not one for which an independent enterprise would have been willing to pay or perform for itself, the activity ordinarily should not be considered as an intra-group service under the arm's length principle.
3. In describing "shareholder activities," the Transfer Pricing Guidelines state that a more complex analysis is necessary when an associated enterprise undertakes activities that relate to more than one member of the group or to the group as a whole. An example would be where a group member (usually the parent company) performs an activity solely because of its ownership interest in one or more other group members, *i.e.*, in its capacity as a shareholder. This type of activity would not be considered an intra-group service and thus would not justify a charge to other group members. Instead, the costs associated with this type of activity should be borne and allocated at the level of the shareholder. Examples would include cost of the juridical structure of the parent company itself, such as meetings of shareholders of the parent, issuing of shares in the parent company, a stock exchange listing for the parent company and the cost of its supervisory board.
4. In contrast, if, for example, the parent company raises funds on behalf of another group member which uses them to acquire a new company, the parent company would generally be regarded as providing a service to the group member.

5. In general, no intra-group service should be found for activities undertaken by one group member that merely duplicates the service that another group member is performing for itself, or that is being performed for the other group member by a third party. An exception may be where the duplication of services is only temporary, for example, where the multinational group is reorganizing to centralize its management functions. Another exception would be where the duplication is undertaken to reduce the risk of a wrong business decision.
6. There are some cases where an intra-group service performed by a group member such as a shareholder or coordinating center relates only to some group members but incidentally provides benefits to other group members. The incidental benefits ordinarily would not cause these other group members to be treated as receiving and intra-group service because the activities producing the benefits would not be ones for which an independent enterprise ordinarily would be willing to pay.
7. In trying to determine the arm's length price in relation to intra-group services, the matter should be considered both from the perspective of the service provider and from the perspective of the recipient of the service. In this respect, the relevant considerations include the value of the service to recipient and how much a comparable independent enterprise would be prepared to pay for that service in comparable circumstances, as well as the costs to the service provider.
8. Depending on the method being used to establish an arm's length charge for intra-group services, the issue may arise whether it is necessary that the charge be such that it results in the profit for the service provider. In an arm's length transaction, an independent enterprise normally would seek to charge for services in a way as to generate a profit, rather than providing the services merely at cost. The economic alternatives available to the recipient of the service also need to be taken into account in determining the arm's length charge. However, there are services in which an independent enterprise may not realize a profit from the performance of services alone, for example, where a supplier's costs (anticipated or actual) exceed market price but the supplier agrees to provide the service to increase its profitability, perhaps by complementing its range of activities.
9. New section D deals with low value-adding intra-group services. This section provides guidance relating to a particular category of intra-group services and provides an elective simplified approach for determining an arm's length charge. It also provides a simplified benefits test.
10. Low value-adding intra-group services performed by one member or more than one member of a multinational group on behalf of one or more other group members include those which (1) are of a supportive nature; (2) are



not part of the core business of the multinational group; (3) do not require the use of unique and valuable intangibles and do not lead to the creation of unique and valuable intangibles; and (4) do not involve the assumption of control of substantial or significant risk by the service provider and do not give rise to the creation of significant risk for the service provider.

11. The following activities would not qualify for the simplified approach:
  - (1) services constituting the core business of the multinational group;
  - (2) research and development services;
  - (3) manufacturing and production services;
  - (4) purchasing activities relating to raw materials or other materials that are used in the manufacturing or production business;
  - (5) sales, marketing and distribution activities;
  - (6) financial transactions;
  - (7) extraction, exploration or processing of natural resources;
  - (8) insurance and reinsurance; and
  - (9) services of corporate senior management.
  
12. Examples of services that likely would meet the definition of low value-adding services:
  - (1) accounting and auditing;
  - (2) processing and management of accounts receivable and accounts payable;
  - (3) human resources;
  - (4) monitoring a compilation of data related to health, safety, environment and other standards regulating the business;
  - (5) information technology services where they are not a principal activity of the group;
  - (6) internal and external communications in public relations support;
  - (7) legal services;
  - (8) activities related to tax obligations; and
  - (9) general services of an administrative or clerical nature.
  
13. As noted, the rule provides a simplified benefits test. Because of the nature of the low value-adding intra-group services under consideration, the determinations regarding benefit may be difficult and may require a greater effort than the amount of the charge warrants. Tax administrators should therefore generally refrain from reviewing or challenging the benefits test when the simplified approach has been applied under the conditions and circumstances discussed in the new Section D, in particular in conformity with the documentation and reporting requirements.
  
14. While low value-adding intra-group services may provide benefits to all recipients of those services, questions may arise about the extent of the benefit and whether independent parties would have been willing to pay for the service or perform it themselves. Where the group has followed the guidance of the simplified approach including the documentation or reporting, it should provide sufficient evidence that the benefits test is met given the nature of low value-adding intra-group services. In evaluating benefits, tax administrators should consider benefits only by categories of services and not on a specific charge basis. Thus, the taxpayer need only demonstrate that assistance was provided with, for example, payroll processing, rather than being required to specify individual acts undertaken that give rise to the costs charged.

15. In determining the arm's length charge for low value-adding intra-group services, the multinational group's provider of services should apply a profit mark-up to all costs in the pool with the exception of any past-through costs as determined in the guidelines. The same markup should be utilized for all low value-adding services irrespective of the categories of services. The markup should be equal to 5% of the relevant cost.

D. Cost Contribution Agreements.

1. Cost contribution agreements are special contractual arrangements among business enterprises to share contributions and risk involved in the joint development, production or the obtaining of intangibles, tangible assets or services with the understanding that these intangibles, tangible assets or services are expected to create benefits for the individual businesses of each of the participants. The report revises Chapter VIII of the OECD's Transfer Pricing Guidelines. It is in response to Action 8 of the BEPS Action Plan covering the transfer pricing of intangibles and requires the development rules to prevent base erosion and profit shifting by moving intangibles among group members without arm's length compensation, as well as an update on the guidance concerning cost sharing agreements.
2. For the conditions of a cost sharing agreement to satisfy the arm's length principle, the value of participants' contributions must be consistent with what independent enterprises would have agreed to contribute under comparable circumstances given their proportionate share of the total anticipated benefits they reasonably expect to derive from the arrangement. Because the concept of mutual benefit is fundamental to a cost sharing agreement, it follows that a party may not be considered a participant because the party does not have a reasonable expectation that it will benefit from the objectives of the cost sharing agreement activity itself, for example, from exploiting its interest or rights in the intangibles or tangible assets, or from the use of services produced through the cost sharing agreement.
3. A party would also not be a participant in a cost sharing agreement if it does not exercise control over the specific risks it assumes under the cost sharing agreement and does not have the financial capacity to assume these risks, as this party would not be entitled to a share in the output that is the objective of the cost sharing agreement based on the functions it actually performs.
4. To the extent of specific contributions made by participants to a cost sharing agreement are different in nature, *e.g.*, the participants perform very different types of R&D activities or one of the parties contributes property and another contributes R&D activities, specific guidance is applicable. This means the higher development risk attached to the development activities performed by the other party and the closer the risk

assumed by the first party is related to the development risk, the more the first party will need to have the capability to assess the progress of the development of the intangible and the consequences of this progress for achieving its expected benefits, and the more closely the party may need to link its actual decision-making required in relation to its continued contributions to the cost contribution agreement to key operational developments.

5. Contributions to a cost sharing agreement may take many forms. For services cost sharing agreements, contributions primarily consist of the performance of services. For development cost sharing agreements, contributions typically include the performance of development activities (*e.g.*, R&D, marketing), and often include additional contributions relevant to the development of the cost sharing agreement such as pre-existing tangible assets or intangibles. All contributions of current or pre-existing value must be identified and accounted for appropriately in accordance with the arm's length principle.
6. The cost sharing agreement will be considered consistent with the arm's length principle where the value of each participant's proportionate share of the overall contributions to the arrangement (taking into account any balancing payments already made) is consistent with the participant's share of the overall expected benefits to be received under the agreement. Where the value of a participant's share of overall contributions under a cost contribution agreement at the time the contributions are made is not consistent with that participant's share of expected benefits under the agreement, the contributions made by at least one of the participants will be inadequate, and the contributions made by at least one other participant will be excessive. In such a case, an adjustment must be made. This will generally take the form of an adjustment to the contribution through making or imputed a balancing payment.
7. Five examples are set forth. I will discuss only Examples 4 and 5. Example 4 was a cause for concern when it appeared in an earlier discussion draft, and Example 5 was the example that greatly troubled commenters.

In Example 4, Company A and B are members of a multinational group and decide to undertake the development of an intangible through a cost sharing agreement. The intangible is anticipated to be highly profitable based on Company B's existing intangibles, its track record and its experienced research and development staff. Company A performs, through its own personnel, all of the functions of a participant in the development of a cost sharing agreement, obtaining an independent right to exploit the resulting intangible, including functions required to exercise control over the risks it contractually assumes in accordance with the principles outlined in the new rules.

Company A will contribute the funding associated with the development of the intangible (\$100 million per year for 5 years). Company B will contribute the development rights associated with its existing intangibles, to which Company A is granted rights under the cost sharing agreement irrespective of the outcome of the agreement's objectives, and will perform all activities related to development, maintenance and exploitation of the intangible. The value of B's contributions (encompassing the performance of activities as well as the use of pre-existing intangibles) would need to be determined and would likely be based on the anticipated value of the intangible expected to be produced under the cost sharing agreement less the value of the funding contribution provided by Company A.

Once developed, the intangible is anticipated to result in global profits of \$550 million per year (year 6 to 15). The agreement provides that Company B will have exclusive rights to exploit the resulting intangible in Country B (anticipated to result in profits of \$220 million per year in year 6-15) and Company A will have exclusive rights to exploit the intangible in the rest of the world (anticipated to result in profits of \$330 million per year).

Taking into account the realistic alternatives of Company A and Company B, it is determined that the value of Company A's contribution is equivalent to a risk adjusted return on its R&D funding commitment. Assume this is determined to be \$110 million per year (for years 6-15). However, under the cost sharing agreement Company A is anticipated to reap benefits amounting to \$330 million of profits per year in years 6-15 (rather than \$110 million). This additional anticipated value in the rights a company obtains (that is, the anticipated value above and beyond the value of Company A's funding investment) reflects the contribution of B's pre-existing contributions of intangibles and R&D commitment to the cost sharing agreement.

A needs to pay for this additional value it receives. Accordingly, the balancing payments from A to account for differences are required. In effect, A would need to make a balancing payment associated with those contributions to B equal in present value, and taking into account the risks associated with this future income, to \$220 million per year anticipated in years 6-15.

In Example 5, the facts are the same as in Example 4 except that the functional analysis indicates Company A has no capacity to make decisions to take on or decline the risk-bearing opportunity represented by its participation in the cost sharing agreement or to make decisions on whether and how to respond to the risks associated with the opportunity. It also has no capacity to mitigate the risks or to assess or to make decisions relating to the risk mitigation activities of another party conducted on its behalf.

In accurately delineating the transaction associated with the cost sharing agreement, the functional analysis therefore indicates that Company A does not control the specific risks under the cost sharing agreement in accordance with the revised OECD Transfer Pricing Guidelines and consequently is not entitled to a share in the output that is the objective of the cost sharing agreement.