

Lab Exercise 00 – PLC Wiring

Use the following steps to wire up the PLC.

Step 1 – wire up 2 Push Buttons using the following diagram as an example:

(wire to X0 and X1 terminals)

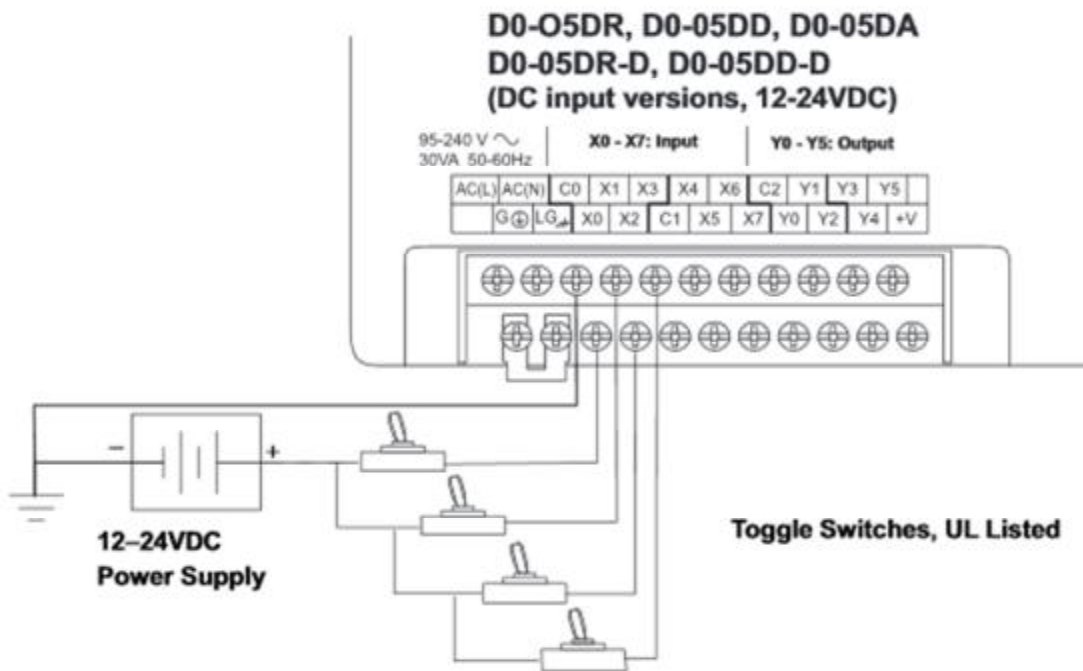

Step 2 – wire up 1 LED using the following diagram:

(wire to Y0 terminal)

More on next page

Step 3 – wire up the power for the System using the following diagram:

