

**San Jose State University
Mechanical Engineering Department**

ME 195 Senior Design Project Summaries

Date: May 12, 2023

SECTION	PROFESSOR	STUDENTS	TIME	ROOM
1	AGARWAL		13:30-16:00	ENG 331
2	FURMAN	23	13:00-15:00	SSW DESIGN CENTER Google map: 84P3+QG
3	TYUKHOV	22	09:30-12:30	ENG331
4	QUACKENBOSS	21	14:00-16:30	ENG401
5	MOKRI	27	09:30-12:00	ENG135
6	ZAIDI	26	13:30-16:30	ENG343
7	KABBANI	23	09:00-11:30	ENG401

Optimization of Powertrain and Suspension Systems for Dynamic Environments

Student Team Members:

Lead: Scott Mink

Jordan Hiestand

Grant Greenlow

Jurel Dizon

Brandon Chang

Sean Krzeczowski

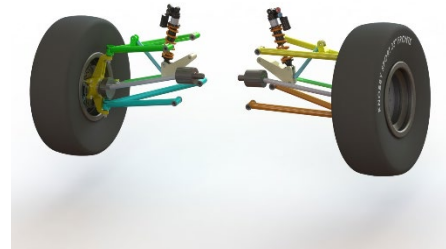
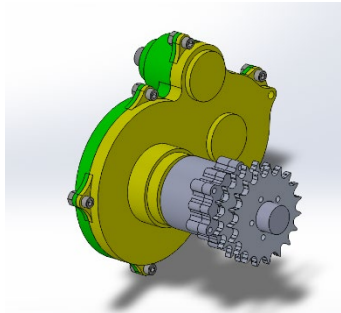

Faculty Advisor:

Dr. Raghu Agarwal

Project Scope and Objectives:

- Make suspension improvements compared to the previous year's car
 - Reduce turn radius
 - Reduce outboard suspension weight
 - Utilize a shock with easily accessible tuning options
- Powertrain improvements
 - Lower the engine by 3 inches to reduce the center of gravity
 - Have enough torque to get up a hill climb of 35 degrees
 - Record a time of under 4.4 seconds in the acceleration dynamic event
 - Reduce the weight of the Powertrain system by 3 pounds

Project Results:

1. Tuning options for the shocks through compression, rebound, and preload adjustment
2. Total weight savings of 8lb; 2lb per corner using lighter shock
3. Tuning options for the CVT through weights, springs, and ramps
4. Gearbox with an integrated sprag clutch

Sponsor:

- Royal Brass
- Polaris
- VR3 Engineering
- Micro-Mechanics
- Grob Inc
- Wilwood
- Haas Foundation
- AiM Sport, LLC
- Lotus
- Kohler
- Cito Medical
- nTopology
- Industrial Metal Supply
- San Jose State University College of Engineering
- San Jose State University Associated Students

FSAE In-Wheel Motor Outboard Assembly

Student Team Members:

A.J. Vallejos - Team Lead
Antonio Lopez
Jesbaam Sanchez
Keaton Fiske
Ulises Chavarria

Faculty Advisor: Raghu Agarwal

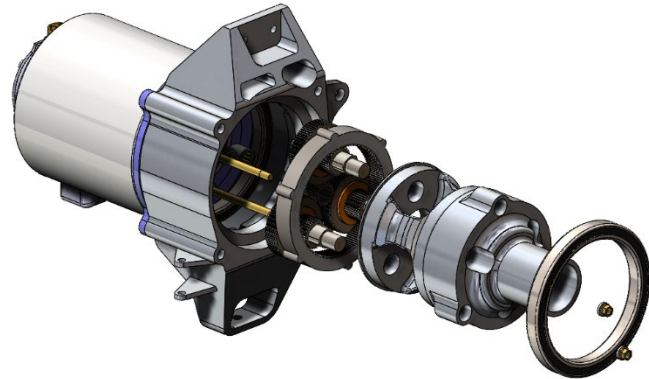

Project Scope and Objectives:

Design and manufacture a prototype of an in-wheel motor outboard suspension package for the Spartan Racing electric FSAE vehicle, to become more competitive in the SAE Collegiate Design Series.

1. Design parts necessary to adapt in-wheel motors to the outboard suspension of the FSAE vehicle, and ensure that designed components comply with FSAE rules
2. Package assembly within an 8" cylindrical wheel shell and avoid interference with suspension components through typical travel
3. Maintain FOS = 1.25 throughout vehicle maneuvers/load cases (cornering, accelerating, braking, & combined)

Project Results:

1. Designed in-wheel powertrain package consisting of 24 parts to accommodate in-wheel electric motors
2. Communicated with local machine shops and drafted professional engineering drawings to secure machining sponsorship of all components
3. Manufactured a 3D printed assembly to test planetary gearbox mesh and overall suspension clearance consisting of 2" vertical travel and 30° steering travel
4. Benchmarked traditional FSAE outboard components and increased upright stiffness by 30%
5. Successfully performed finite element analysis to ensure that the entire outboard assembly will not yield under expected load case(s) or fatigue under typical competition season conditions

Sponsor: SJSU Spartan Racing FSAE

Fiber Alignment System for Silicon Photonics

Student Team Members:

Andrew Duong (Team Lead)

Claudia Bird (Programming Lead)

David Oiwa (Design Lead)

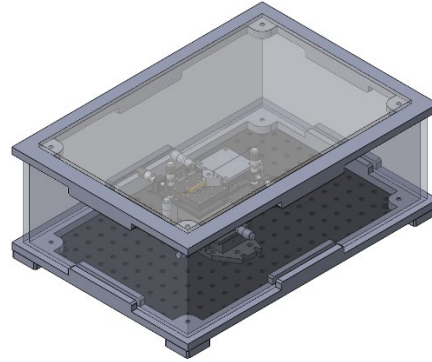

Faculty Advisor: Dr. Raghu Agarwal

Project Scope and Objectives:

The main objective of this project is to create a proof of concept automated system that can align optical fibers to a specified target using feedback from a light intensity sensor. This proof of concept is a stepping stone towards systems that can automatically align optical fibers for the purposes of fiberizing silicon based photonics integrated circuits.

1. Perform research on alignment systems and fibers and what components are required for a system. Use this research to select viable components for the construction of the project
2. Design a system to:
 1. Allow users to position fiber with controls.
 2. Automatically align the core of an optical fiber to a static target with a light loss of less than 0.15dB using feedback from the light sensor. Process should be repeatable and have stable results.
 3. Dampen vibrations from outside sources and sound coming from the piezo motors.
3. Validate the system by testing the alignment of the fiber visually and through the amount of light loss compared to a direct feed from source to sensor.

Project Results:

1. Design for the system that includes all the necessary components and emulates a target for the fiber; Solidworks Assembly draft of the design.
2. Bought all necessary physical components, designed and printed custom fixtures, and assembled a physical system.
3. Created a main program that successfully runs algorithms to find first light and search for the peak power point.
4. Tested system and recorded light loss after alignment process.

Sponsor:

Jabil

Variable Volume Autonomous Tray Filler

Student Team Members:

Zachariah Davidson (Team lead)

Avi Ben Tov

Gabriel Gonzalez

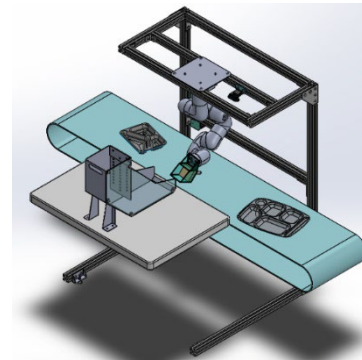

Faculty Advisor: Raghu Agarwal

Project Scope and Objectives:

Design and build an autonomous tray filling system proof of concept that incorporates a variable volume scoop.

1. Design, model, and program a scoop that can change volume.
2. Design and build a hopper for testing angle of repose of different aggregates
3. Design and build a frame that can be easily modified for further testing and integrates easily with existing processing assemblies (i.e. conveyors)
4. Use machine vision to simulate analyzing UV ink embedded indicators for determining dropoff points on varied tray designs, eliminating the need for indexing functions
5. Program an entry-level 6-DOF robot arm to consistently deliver product within 10% of anticipated volume without spillage.

Project Results:

1. Successfully designed variable volume scoop, hopper, frame, circuits, process flow, program structures
2. Successfully manufactured variable volume scoop, hopper, frame
3. Successfully programmed automated machine vision (MV) to detect 2D reference objects and apply transformations relative to robot arm to consistently locate dropoff locations regardless of visual noise
4. Successfully integrated variable volume scoop, MV, and robot motion to deliver specified product to specified locations

Sponsor:

Heinzen Manufacturing International

DESIGN AND DEVELOPMENT OF A SINGLE DEGREE OF FREEDOM UPPER BODY ASSISTIVE EXOSKELETON

Student Team Members:

- Nathanael Lacuata
- Brandon O'Dell
- Anthony John
- Cameron Pelletier
- David Jefferson
- Richard Lineberger

Faculty Advisor:

Dr. Mojtaba Sharifi
Dr. Raghu Agarwal



Project Scope and Objectives:

Develop a single degree of freedom upper limb exoskeleton for purposes of mobility assistance that meets the following criteria:

1. Be adjustable in size for all body types.
2. Have a lightweight and ergonomic design.
3. Lower cost by utilizing only one high-torque motor per joint.
4. Have each joint be actuated by displaced motors via a bowden cable and pulley system.
5. Have movement be controlled through use of gyroscopes and accelerometers on another arm.

Project Results:

1. Successfully designed an adjustable, lightweight, single degree of freedom upper-limb exoskeleton with a wide range of motion.
2. Sourced and manufactured components to successfully construct a working prototype of this exoskeleton design.
3. Successfully designed a control system using gyroscope and accelerometer sensors.
4. Successfully able to track the position of the monitored arm relative to the user's body.

Sponsor:

Dr. Mojtaba Sharifi, San Jose State University Mechanical Engineering Department.

An Adaptive Cruise Control Model for Automated Transit Networks

Student Team Members:

Heather Knoblach (Team Lead)
Sai Hein Si Thu
Zubin Parvereshi
Nagarjuna Patluri
Jonathan Seryani
Nate Smurthwaite

Faculty Advisor:

Dr. Burford Furman



Project Scope and Objectives:

Build an adaptive cruise control system for a scale model vehicle of the Spartan Superway transportation system which will detect other vehicles on the guideway and adjust speed accordingly.

1. Redesign the housing and camera mount for a more secure enclosure of the system and provide at least a 60° horizontal field of view.
2. Obtain object detection with at least 80% accuracy beyond 1-ft. separation.
3. Design a closed-loop control system that will ensure the vehicles stay 15-in. apart.

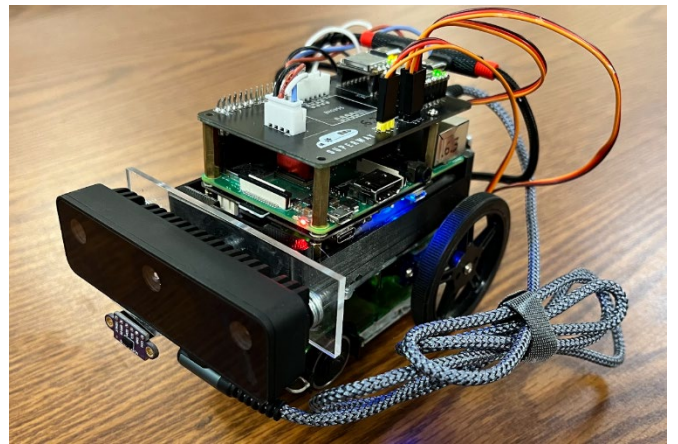

Project Results:

1. Successfully redesigned the housing and camera mount, providing a more compact structure while maintaining at least a 60° horizontal field of view.
2. Successfully obtained object detection with an average of 80% accuracy for objects beyond 1-ft.
3. Successfully designed and tuned a PID speed controller which ensures that the vehicles are approximately 15-in. apart at all times.

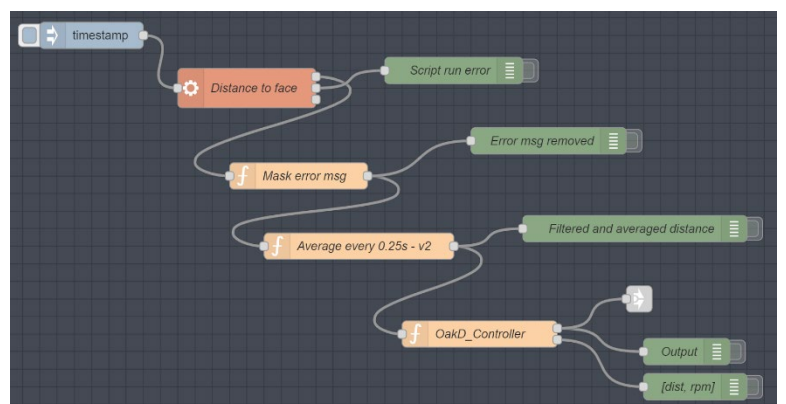

Sponsor: Spartan Superway

Design and Fabrication of Network Scale Energy Storage and Charging Station of the SPARTAN Superway

Student Team Members:

Raiden Romero (Team Lead)
Christian Chaves
Jeremy Mendoza
Luis Moreno
Reyad Ramsey

Faculty Advisor:

Dr. Burford Furman

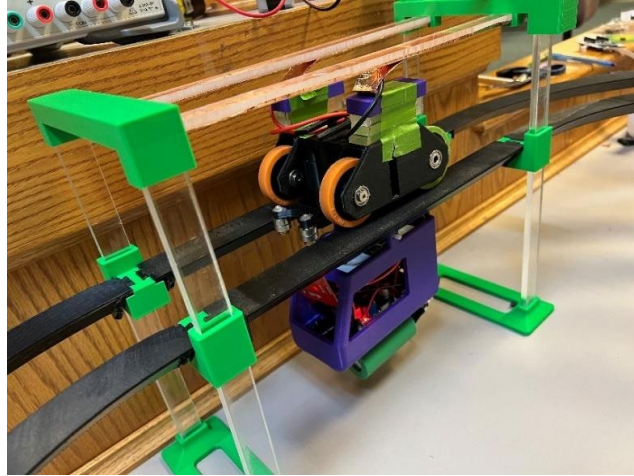

Project Scope and Objectives:

Design and fabricate a charging interface for the network scale vehicles (bogies), and design and package an energy storage circuit for the bogies.

1. Design a charging “station” or interface that meets the following specifications:
 1. Capable of charging the bogies autonomously
 2. Allows the bogies to return to normal operation once charging is complete
2. Design and integrate an energy storage circuit consisting of batteries and/or supercapacitors on a bogie that meets the following specifications:
 1. Capable of powering the bogie for 30 minutes on one full charge
 2. Does not exceed one pound in weight
 3. Capable of being sufficiently charged in less than an hour
3. Redesign the bogie chassis to accommodate the energy storage circuit.
4. Record the charging data and battery status to Influx DB and display the data on Grafana.

Project Results:

1. Successfully designed and fabricated a charging station for the network scale track that meets all of the design specifications.
2. Successfully designed and integrated an energy storage system on a network scale bogie that meets (or exceeds) all of the design specifications.
3. Successfully redesigned and fabricated the network scale bogie chassis that accommodates the components of the energy storage circuit.
4. Successfully configured a system that records supercapacitor status and charging data to InfluxDB and displayed it with Grafana.

Sponsor: Spartan Superway

Small Scale Track Spartan Superway

Student Team Members:

Justin-Tam Nghi (Team Lead)
Allen Ma (Communication Lead)
Brandon Cline (Manufacturing Lead)
David Lopez Rodriguez
Hao Tran
Manraj Bhangu
Pawan Kattel (Fabrication Lead)

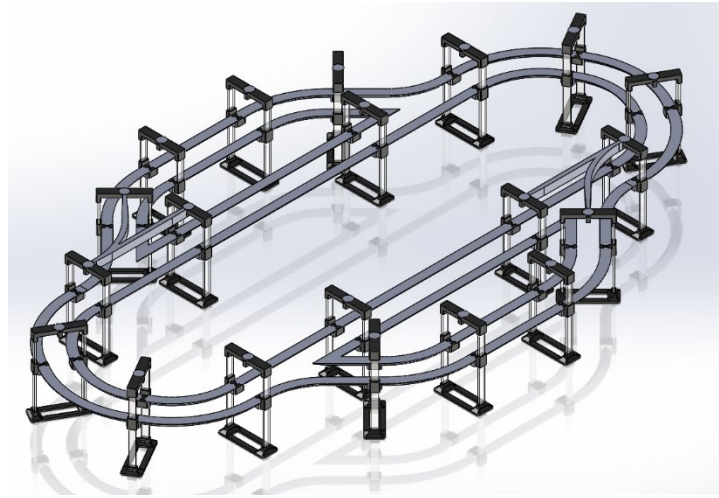

Faculty Advisor: Dr. Burford Furman

Project Scope and Objectives:

Design and build a modular small-scale track for the Spartan Superway to imitate a sustainable public transportation system.

1. Create and build a modular scale model guideway as a replacement for the current network scale model of Spartan Superway.
 - a. Capable of being assembled in 30 minutes or less by two or three individuals.
 - b. Reduce 90% of hardware
 - c. Fully modular, able to insert and replace parts of the track
 - d. Integrate RFID tags into the small-scale track to locate the bogey's position.
2. Improve small scale modular track with commercial components, not all parts to be made of PLA.
 - a. Design bogey to incorporate into small scale modular track
 - b. Design a bogey using the old switch arms to be compatible with the guides above the track.
 - c. Utilizer servos that rotate from 0 to 180 degrees for the switch arms.

Project Results:

1. Successfully build modular small-scale track
2. Successfully assembled small scale track within 30 minutes with three people
3. Successfully reduce hardware amount by 90% from the core team track
4. Successfully designed and built a bogey for small scale track
5. Successfully incorporated old switch arm design into new bogey design.

Sponsors:

Spartan Superway, Keysight Technologies, Swenson Technologies, INIST

SPARTAN Superway Electric Motor Dynamometer

Student Team Members:

David Cortes
Kirubiel Gebreselassie
Jose Gutierrez
Aryan Jadhav
Christian Potenti (Team Lead)

Faculty Advisor:

Dr. Burford Furman

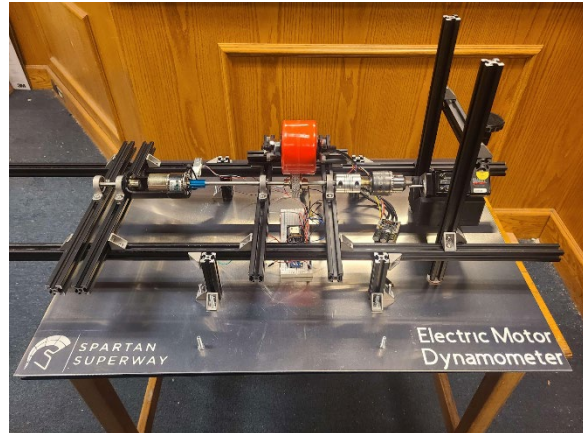

Project Scope and Objectives:

Design and build an electric motor dynamometer to test the various motors used by the SPARTAN Superway on their vehicle prototypes.

1. Design a dynamometer to obtain the main parameters from a motor including RPM, and torque.
2. Design motor mounts to accommodate hub motors and shaft-type motors (DC motors, stepper motors, smart motors, etc).
3. Design to fit straight shaft diameters ranging from 2.5 mm to 18 mm.
4. Design to fit and handle motors that range from 5 volts to 48 volts.
5. Set-up time to switch between motor types must be under 5 minutes.
6. Test motors up to speeds of 600 rpm.
7. Make sure the system has IoT integration and is able to run influxDB and Grafana for data analysis.

Project Results:

1. Successfully designed an electric motor dynamometer capable of measuring RPM and torque, as well as voltage, current, and motor running temperature.
2. Successfully designed motor mounts that accommodate all motors mentioned.
3. Successfully designed couplers and drivetrain that handles motors of different voltages and various shaft sizes
4. Successfully integrated sensors, and microcontrollers to give IoT integration and run influxDB and Grafana.

Sponsors:

SJSU, SPARTAN Superway.

Repairing and Modernization of PV System in SJSU Community Garden

Student Team Members:

Jun Lang Lin (Team Leader)

Konrad Wolf

Luan Vo

Faculty Advisor: Dr. Igor Tyukhov

Project Scope and Objectives:

Our goal is to repair and modernize the existing two PV arrays with balance of system (BoS) in the SJSU Community Garden.

1. Repairing BoS, modernization BoS functions by changing elements, creating new electrical schemes, and drawing schematics according to the new MPPT user manual to avoid problems with the discharging and overcharging batteries.
 1. The user should be able to power any DC and/or AC loads as a refrigerator, microwave, and projector using the repaired BoS.
 2. PV systems should be protected from discharging batteries.
2. Creating a manual for the community garden manager and other users. This PV system can be used by any future team or for demonstration and promotion of clean energy generation among people wanting to understand how the autonomous system works.
3. Tilting first PV array for optimization of generating power and cleaning the solar panels. Measuring results after establishing new orientation and cleaning of receiving surfaces of solar arrays.

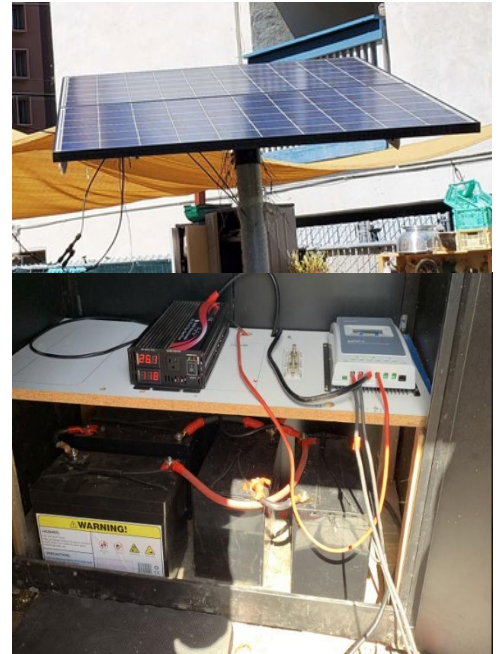

Project Results:

1. Successfully repairing the PV system and using the BoS to power the aforementioned appliances.
2. Modernizing the PV system adjusting output voltage from solar modules with the BOS. Installing monitors with the sensors, allowing the user to remotely track the state PV system observing solar generation and usage.
3. The students acquired experience handling electrical components, such as MPPT, inverter, fuses, batteries, and solar panel, that make up the BoS and understanding balance of energy in real PV systems.

Sponsor:

SJSU Community Garden Manager, Matthew Spadoni

Design, Manufacture, and Optimization of a Desktop CNC Router

Student Team Members:

Marco Koch (Team Lead)

Kyle Boardman

Miguel Guzman-Alvarez

Erik Hull

Faculty Advisor: Igor Tyukhov

Project Scope and Objectives:

Design, manufacture, and optimize a desktop CNC router to improve on material Removal Rate and accuracy to suit 6061 T6 aluminum plates.

1. Design CNC Router CAD Model
2. Source Components, Assemble and Tram Router
3. Test the performance of the CNC machine and compare to the stock 3018 kit
4. Improve rigidity of CNC machine by at least 30% of the stock 3018 kit
5. Increase Material Removal Rate (MRR) of the CNC machine by at least 15% of the stock 3018 kit

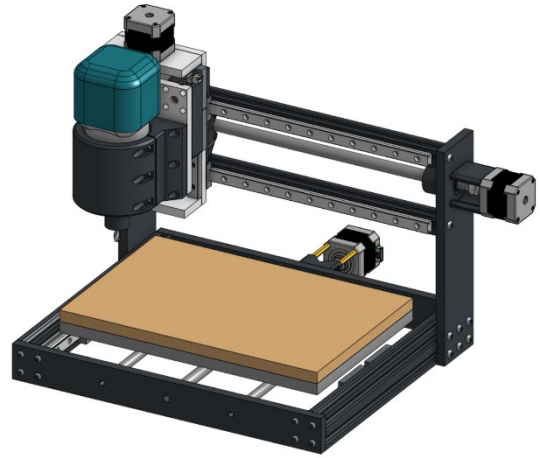

Project Results:

1. Successfully designed 3D CAD model and performed analysis to determine appropriate dimensioning of components
2. Successfully sourced components and assembled and trammed the router
3. Successfully tested the performance of the CNC machine by making test cuts in 0.25" T6 6061 aluminum plates
4. Successfully increased rigidity of the stock 3018 kit by 45%
5. Successfully increased Material Removal Rate (MRR) of stock 3018 kit by more than 15%

Sponsors:

Marco Koch, JP Metal Fabrication

Smart Personal Vehicle Drivetrain

Student Team Members:

Chiu Chun Tsang
Hyon Kim
Jacob Schauerman
Schuyler Zandbergen

Faculty Advisor:

Professor Igor Tyukhov

Project Scope and Objectives:

Provide a functional drivetrain to the Smart Personal Vehicle:

The vehicle should be able to move forward and reverse with the motor drive at a top speed of 25 mph and a range of 40 miles for purely motor driven travel. It should be able to move under pedal power.

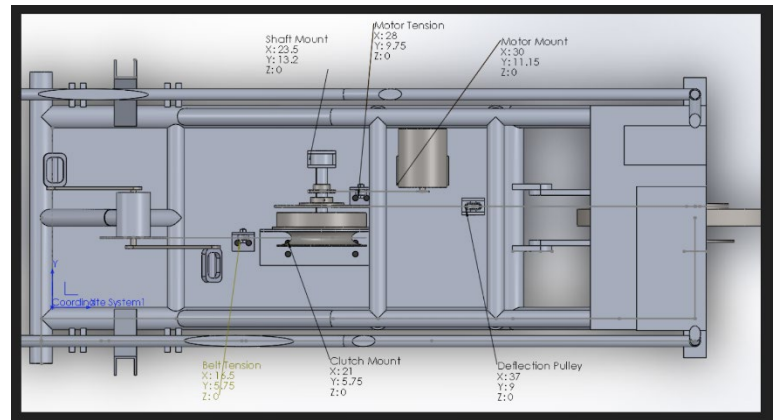

Project Results:

1. Rearrangement of components
2. Additional bracket fabrication
3. Intermediary shaft fabrication
4. Updated electrical diagram
5. Belt drive alteration
6. Direct drive capability
7. Installing electric clutch for reverse motion

Sponsor:

Prof. Raymond Yee

Design and Elaborating Photovoltaic-Thermal Dryer for SJSU Community Garden

Student Team Members:

Adriano Viveiros (Team Lead)
Diane Saefong
Juan Escobedo Silva
Nathaniel Te
William Guan

Faculty Advisor: Dr. Igor Tyukhov

Project Scope and Objectives:

This project centers around the development of a thermal and photovoltaic solar dryer (or dehydrator) for food or other organic products, particularly leaves, fruits, and vegetables for the SJSU Community Garden.

- Generate a dryer system that meets the basic needs of the customer
- Create and design a modular solar heat collector with assistance of fans using solar power
- Achieve heating target potential of 120 degrees Fahrenheit for drying 12-15 trays of product
- Code for different temperature or power settings that can be selected from a display
- Determine suitable food safe materials and construction methods

Project Results:

1. Finalized modular design with food safe interior
2. Bought construction materials costing around the provided budget
3. Acquired adequate tooling for construction process
4. Tested and calibrated electronics through code
5. Recorded temperature inside the heat collector ranges from 115.14°F to 153.82°F on a warm 82°F day in the afternoon (3pm)
 1. When in shade, the average temperature inside the heat collector reached 109.98°F
 2. When in direct sun, the average temperature inside heat collector in sun 130.69°F
6. After testing the heat collector, an inverse relationship was found where as the duty cycle of the fan increases (fan speed), the outlet air temperature from the heat collector decreases (20 duty cycle equal around a 2-3°F drop)

Sponsor: SJSU Community Garden

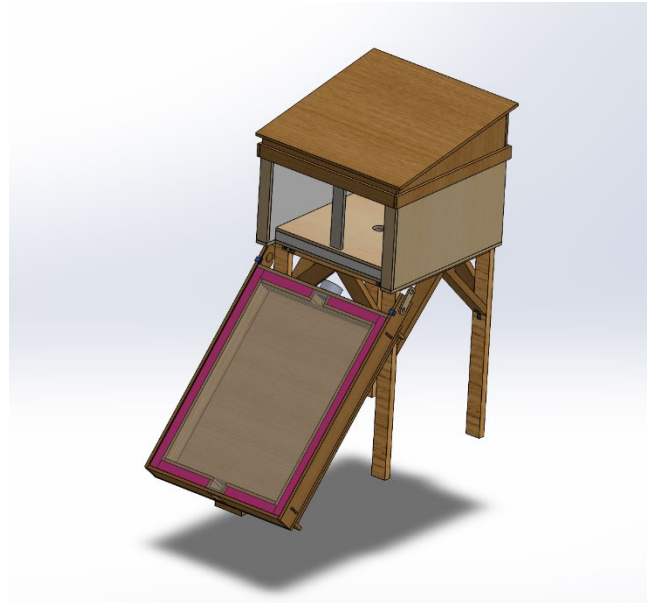

Development of Photovoltaic Ultrasonic Mist Maker Humidifier for Dry Climate Areas.

Student Team Members:

Vivian Tran (Team Lead)
Joshua Fountain
Fernando Medina

Faculty Advisor: Dr. Igor Tyukhov

Project Scope and Objectives:

Design and build a solar powered ultrasonic humidifier for indoor purposes.

1. Displays Temperature and Humidity levels on the display
2. Uses solar power only to run the humidifier
3. Includes 3 different mist levels (low, normal, high)
4. Includes a timer to run humidifier for a certain amount of time
5. Humidifier must be able to run for 8 hrs
6. Device must be able to move locations and be portable
 1. Less than 25 lbs
7. Auto shutoff when humidity levels get above 60%

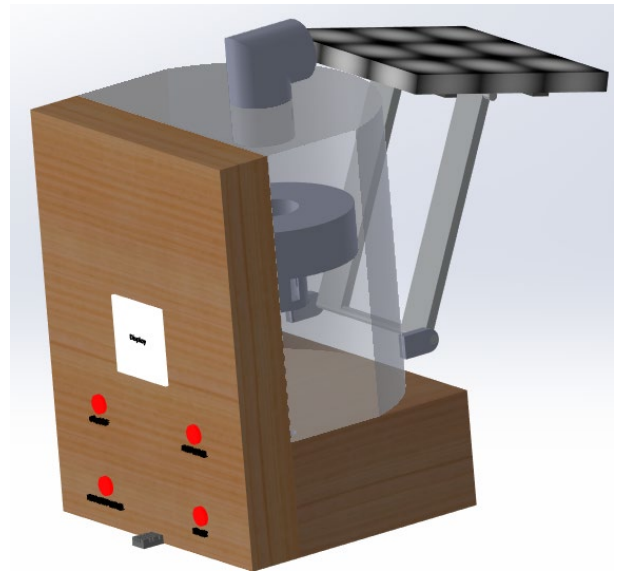

Project Results:

1. Sensor reads temperature and humidity and displays it on LCD screen
2. When exposed to the sun, solar panel converts solar energy into electrical energy that is stored in the battery to run the humidifier
3. No fans running is the lowest mist level, one fan is normal, two fans - high level
4. Microcontroller accepts user-inputted timer to turn off the power once timer runs out
5. The tank holds enough water and the battery holds enough charge to run for 8 hrs
6. Device weighs 18 lbs including the weight of the water and is portable
7. If the sensor gets a humidity reading above 60%, the humidifier will shut off.

Sponsor:

N/A

Comparison of Gasoline and Electric Drivetrains on a Go Kart

Student Team Members:

Joshua Ford (Team Lead)

Gabriel Cruz

Brandon La

Francis Supnet

Faculty Advisor:

Professor Harry Quackenboss

Project Scope and Objectives:

1. Create a representative CAD of the design for the electric go kart after the conversion
2. Convert the internal combustion engine go kart to the electric motor go kart
3. Compare the performance between two powertrain in the scope of 50 yards
4. Measure the fuel and energy consumption for both powertrains

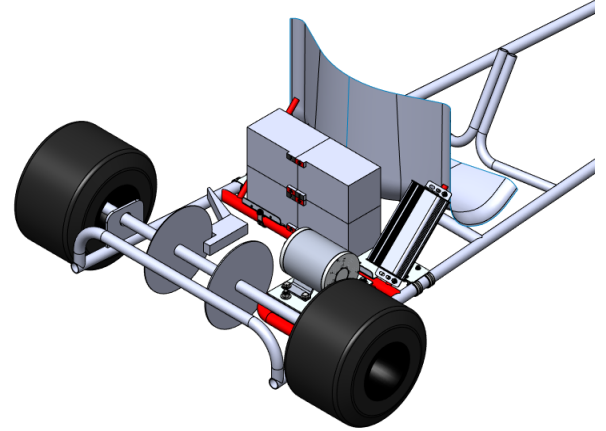

Project Results:

1. Successfully created a representative CAD on SOLIDWORKS of the physical go kart that allowed us to design the parts necessary for the electric conversion
2. Completed the drivetrain conversion resulting in a running go kart powered by an electric motor
3. Completed 50 yard testing runs with both combustion and electric drivetrains with the electric drivetrain having a faster acceleration time
4. Found the electric drivetrain to be more energy efficient than the combustion drivetrain

Sponsors:

Charles W. Davidson College of Engineering's Department of Mechanical Engineering, The project members.

Hybrid Bicycle Conversion

Student Team Members:

Malcolm Jeng (Team Lead)

Ivan Garcia Higareda

Amir Abousteit

Faculty Advisors:

Harry Quackenboss (ME 195B)

Vimal Viswanathan (ME 195A)

Edward Cydzik (ME 195A)



Project Scope and Objectives:

The goal of this project is to convert a pedal powered bicycle into a hybrid bicycle using a hub-drive electric motor conversion kit.

Objectives:

- Design spacer for battery mount to retain folding capability
- Top speed runs with different weights
- Range test
- 50-foot acceleration test

Project Results:

1. Top speed: 15 MPH
2. Battery-only range: 14.26 miles
3. 0-50 foot acceleration tests (pedal only, motor only, and combined)

Sponsor:

Vimal Viswanathan

Electric Human Powered Vehicle (e-HPV)

Student Team Members:

Hector Rincon (Team Lead)
Andrez Bernal
Mandeep Singh
Cameron Reyes
Nay Chi Moe Htet
Mia Mendoza



Figure 1: e-HPV Bike Modified

Faculty Advisor: Professor Harry V. Quackenboss

Project Scope and Objectives:

1. Reconstruct and modify an HPV with the integration of electrical components
2. Compete in the ASME Human Powered Vehicle Challenge (HPVC)

Project Results:

So far, we were able to accomplish this by installing a new e-bike kit system onto an existing bike frame and wheels. The kit itself included: Motorized Mountain Bike Wheel, LCD Display, 75 Freewheel, Motor Controller, Pedal Assist Sensor, Brake Lever Set, 1T4 Harness Cable, Motor Cable, and Torque-Arm Set.

For the sake of the competition, we are required to include a parcel box to store groceries as a way to implement this project idea in third-world countries. Therefore, we decided to create a storage system for our electrical components right underneath the parcel box.

After the build of our overall system, our e-HPVC bike runs like expected however, currently has balancing issues. To solve this problem, we decided to remove the old training wheels and install a more stabilized set of training wheels by welding onto the frame of the bike.

For FEA analysis of the bike we performed an analysis of the rollover protection system (RPS). The RPS must support top load when apply 600lbf 12 degree toward the back of the vehicle and side load when apply 300lbf shoulder height toward the side of the vehicle. For structural analysis, we performed an FEA analysis on the bike frame to determine stress and displacement act upon the structural of the frame when we apply ~ 250 lbf (maximum rider weight) and gravitational force.

Sponsor:

American Society of Mechanical Engineers San Jose State University
Fusion 360
Dremel

Redesign and Conversion of a Chain-Driven Bicycle to a Belt-Driven Bicycle

Student Team Members:

Pablo Correnti (Team Lead)
Ninous Aprim
Alexander Garcia
Sebastian Pineda

Faculty Advisor: Harry Quackenboss

Project Scope and Objectives:

Complete the conversion, and compare the performance of a chain-driven bicycle versus a belt-driven bicycle.

1. Run tests on chain-driven bicycle
 - a. Sound, RPM, weight, and speed
2. Convert the bike from chain to belt
 - a. Install front and rear sprockets
 - b. Replace rear wheel to allow for proper sprocket
 - c. Cut frame and install space for belt installation
3. Run tests on belt-driven bicycle
 - a. Sound, RPM, weight, and speed
4. Compare efficiency and data gathered from the chain-driven bicycle and the belt-driven bicycle

Results:

1. Successfully ran tests on chain-driven bicycle
2. Successfully converted bike from chain to belt drive
3. Successfully ran tests on belt-driven bicycle
4. Successfully compared efficiency and data between chain-driven bicycle and belt-driven bicycle

Sponsor: None



DESIGN OF AUTOMATED SORTER FOR ANODIZING PLUGS

Student Team Members:

Maciah Bey
Joshua Cooney
Karen Pham
Gabriel Yee (*Team Lead*)
Tyler Yee

Faculty Advisor:

Dr. Harry V. Quackenboss

Project Scope and Objectives:

1. Separate the plugs individually for analysis
2. Scan with image processing to obtain plug data
3. Use mechanical design to efficiently load the plugs into analysis chamber
4. Sort faster or equal compared to a manual human sorter (6-10 hours per week)
5. Implement user safety, ease of use, and reparability features

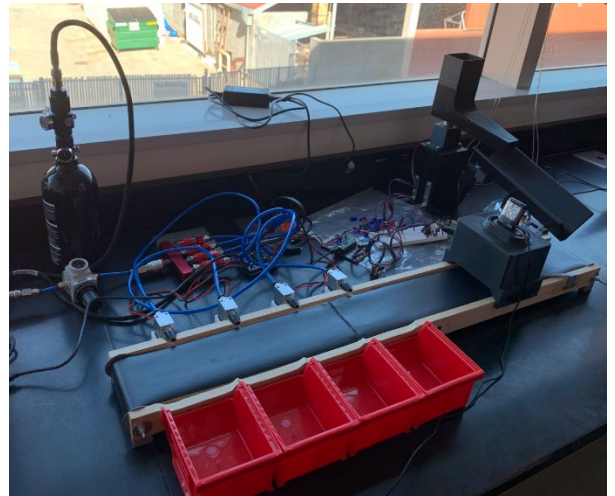

Our designed product will be able to intake mass quantities of silicone anodizing plugs varying in color to sort and organize them utilizing mechanical design and image processing.

Project Results:

1. Fully functional anodizing plug sorting machine
2. Can individualize plugs for sorting via image processing that determines color
3. Sort plugs into bins through air system once color is detected
4. Under 10% error of sorting (comparable or better to human)

Sponsor:

This project is sponsored by the Mechanical Engineering Department, Semano, and project members.

Jabil: Smart Manufacturing Dashboard Visualization

Student Team Members:

Jason Luu (Team Lead)

Mario Barajas

Jasmine Nguyen

Faculty Advisor:

Harry Quackenboss

Project Scope and Objectives:

Build a dashboard showcasing visualizations from a SMT assembly line.

1. Build visualizations from SMT data
 1. Identify the best type of chart
 2. Test automatic data entry feature
2. Compile visualizations into dashboards
 1. Varying views for different user roles
 2. Front-load critical information

Project Results:

1. Fully completed dashboard
2. Visualizations depicting error data
3. List of recommendations for software updates

Sponsor:

Jabil, Cimatrix

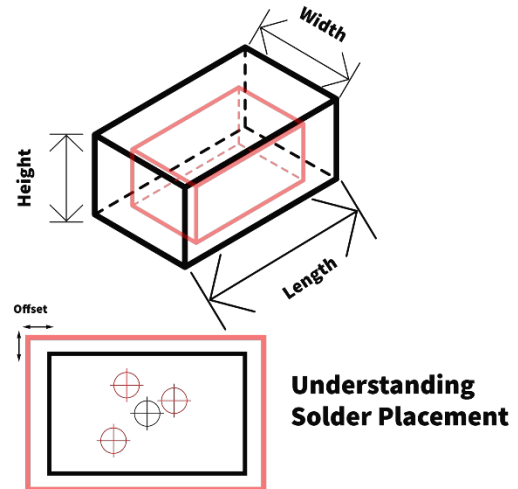

Jabil: Dual Cure Adhesive for Use with Active Alignment

Student Team Members:

Alexander Boggini (ME team lead)

Naenedy Lopez (BME team lead)

Timothy Samy (BME team lead)

Faculty Advisor: Harry Quackenboss

Project Scope and Objectives:

Qualify a new adhesive for Jabil to use with active alignment for camera modules. This adhesive must be equal to or better than the baseline adhesive currently used at Jabil.

1. Perform research to determine a list of suitable adhesives for active alignment with camera modules.
2. Use materials characterization equipment to verify material properties of adhesives.
3. Use materials characterization data and technical data sheets to down select viable adhesives.
4. Create a test plan and manufacture samples for pull testing.
5. Create a mechanism to adapt an Instron pull tester to perform pull tests on our samples.
6. Compare data from pull testing and materials characterization to determine which adhesive outperformed or matched the performance of the baseline adhesive.

Project Results:

1. Successfully created Jabil TIAP, SOW, and DOE documents.
2. Successfully created a matrix with several adhesives and their properties.
3. Successfully tested adhesives using Rheometer, Calorimeter, and Instron force tester.
4. Successfully machined new grips for Instron force tester to hold our samples.
5. Successfully machined samples to dispense adhesive on to.
6. Successfully qualified a new adhesive for Jabil to use for active alignment.

Sponsor:

Jabil



3D Metal Printed Pedicle Screws with PMMA Adhesive

Student Team Members:

Jungtae Kim (Mechanical)-Team Lead
Margarita Garcia (Bio-Medical)-Team Lead
Jason Do (Chemical)-Team Lead



Faculty Advisor:

Harry Quackenboss (ME195B_Professor)

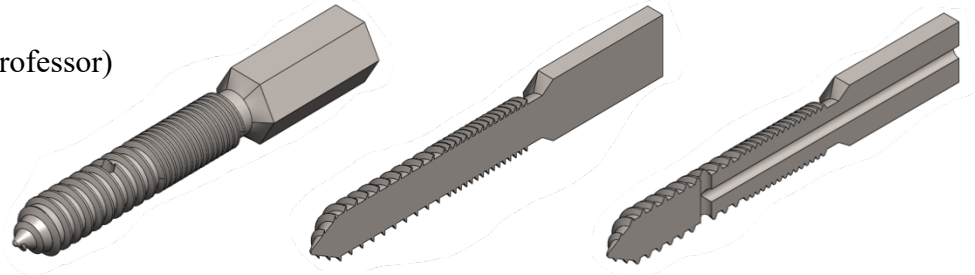

Project Scope and Objectives:

- The experiment will test the torque of the pedicle screw with bone cement augmentation. The materials needed for this experiment are 3D printed pedicle screws, bone cement, and bone simulant. The tools and instrumentation used for the experiment will be torque wrench and bone foam. The experiment will consist of screwing the pedicle into a substrate similar to human bone. The test will determine the strength of the design of the screw, diameter and threads.
- Compare torque out strength between traditional and augmented pedicle screw designs, with differing PMMA adhesive applications.

Project Results:

1. Successfully designed an improved pedicle screw.
2. Successfully created various types of edible screw with 3D printer.
3. Successfully figured out the optimal diameter of cannulation.
4. Successfully figured out the best method for fixation having the highest torque value.

Sponsor:

San Jose State University, Jabil

Optimized Process for Sintered Nano Copper Paste for use as Die Attach Material

Student Team Members:

Jeovany Alvarenga (Materials Lead)

Raul Ochoa (Electronics Lead)

Julio Sanchez (Mechanical Lead)

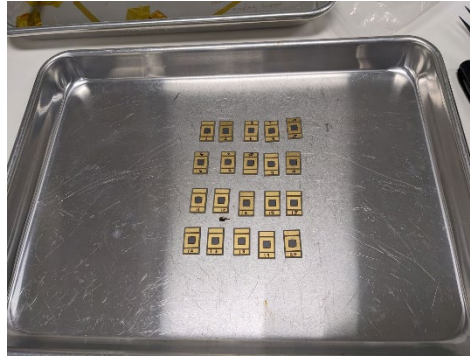

Faculty Advisor:

Harry V. Quackenboss

Project Scope and Objectives:

Determine a sintering manufacturing process for nano copper paste for use in building high powered electronics.

1. Perform literature research on nano copper paste, sintering, and electronic packaging.
2. Obtain a nano copper paste from a manufacturer
3. Determine sintering profiles to be tested before using copper paste
4. Assemble test vehicles and perform zero-hour testing
5. Establish and perform reliability testing

Project Results:

1. Obtained an experimental nano copper paste from a manufacturer
2. Sintering profiles determined (Sintering Temperature – Ramp Rate – Dwell Time) under N_2 atmosphere < 1000 O_2 ppm
 - a. 250 °C – 15 °C/min – 30 min → Baseline profile from manufacturer TDS
 - b. 250 °C – 15 °C/min – 20 min
 - c. 210 °C – 15 °C/min – 45 min
3. Die shear strength
 - a. Test vehicle #33 was 2.174 kg (FAIL)
 - b. Test vehicle #39 was 0.884 kg (FAIL)
 - c. Failed to meet MIL-STD 883K min die shear strength of 2.5 kg
4. Unsuccessfully sintered nano copper paste onto substrate

Sponsors:

San Jose State University, Jabil

Jabil Fluidics: Flow Sensor Characterization

Student Team Members:

Matthew Morano (Team Lead)

Ricardo Munguia

Cooper Gable

Faculty Advisor:

Harry Quackenboss

Project Scope and Objectives:

Construct a flow system capable of delivering steady flow rates to help characterize two Sensirion flow sensors based on different liquid mediums.

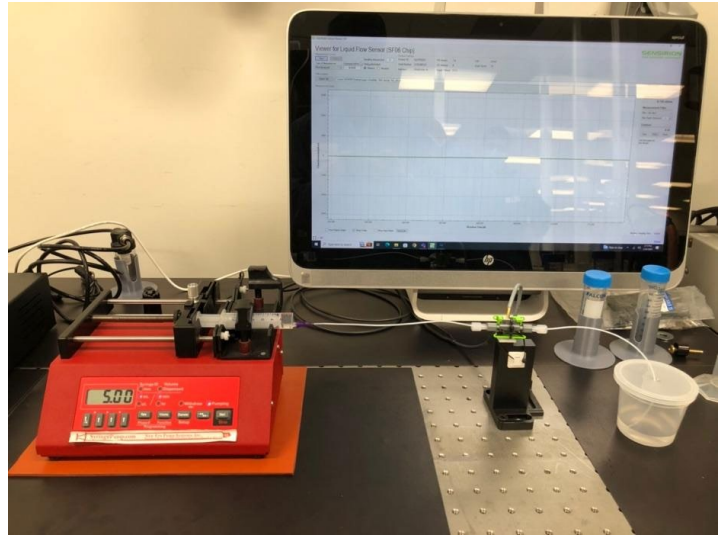

1. Perform a feasibility study on the components of our flow system to determine whether or not our experiment could be conducted. Components consisted of two liquid flow sensors, a syringe pump, and Sensirion software.
2. Conduct a Gage R&R study on a syringe pump to determine the repeatability and reproducibility of said pump. Doing so would further solidify our results and help narrow down possible sources of error within our results.
3. Characterize two liquid flow sensors with different ranges for flow rates using deionized water, saline solution, and mineral oil. Comparing data collected from Sensirion software with our calculated gravimetric flow rate, we could determine whether the sensor is within specification and the best possible application for it.

Project Results:

1. Successfully performed a feasibility study and determined that experiment was possible.
2. Successfully conducted Gage R&R study and determined that machine and each operators' percent contribution to total variation was negligible.
3. Characterization of first liquid flow sensor was successful and average percent differences were well within sensor specifications for all three liquid mediums
4. Characterization of second liquid flow sensor was also successful, however, average percent difference was quite high for deionized water at a higher flow rate. Larger average percent differences were expected for saline solution and mineral oil.

Sponsor:

Jabil Scholars, SJSU

Soldering of Electrical Components to Aluminum

Student Team Members:

Aisha Tabraiz (Team Lead)

John Louis Parayno

Azfar Khan

Faculty Advisor:

Harry V. Quackenboss

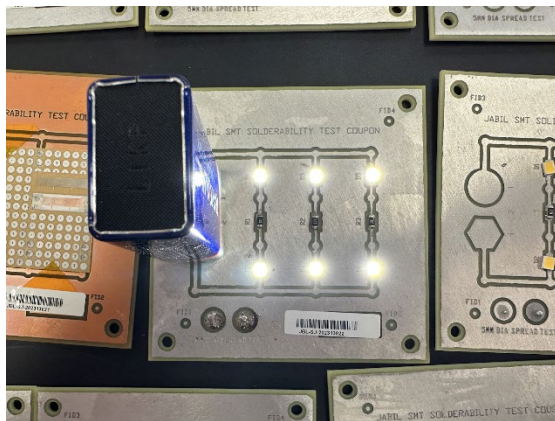
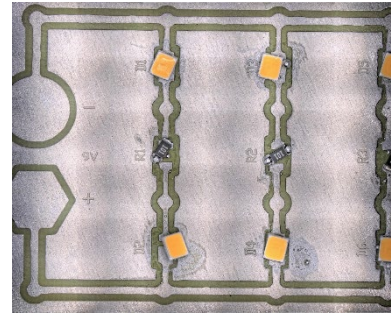

Project Scope and Objectives:

Develop a process to solder electrical components to an aluminum PCB

1. Perform research on existing methodologies and how to implement them
2. Utilize various pre treatment methods to improve the effectiveness of aluminum soldering
3. Analyze effectiveness of solder joints through destructive and non-destructive methods
4. Determine which process is the best method for producing consistent results

Project Results:

1. Obtained aluminum soldering materials from SuperiorFlux and Indium
2. Developed a matrix containing processes and their results
3. Utilized X-ray imaging, microscopic imaging and cross section analysis to determine the quality of the solder joints
4. Final results of aluminum soldering varied greatly
5. Only a handful of boards out of 25 aluminum boards ended up with functioning components

Sponsor:

Jabil

Low-Cost Wildfire Suppression Robot

Student Team Members:

Andrew Each
Genevieve Ferrer (Team Lead)
Jonathan Leodones
Edwin Navarro
Anthony Peters

Faculty Advisor: Professor James Mokri

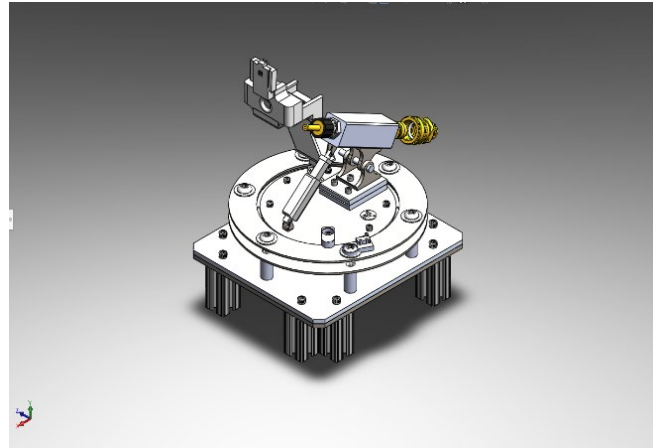

Project Scope and Objectives:

Design, program, and build a remote-controlled wildfire suppression robot.

1. Design and build a robot that meets the following specifications:
 1. Capable of spraying water at a distance of 10 feet
 2. Capable of rotating +/- 90 degrees in pitch direction and +/- 10 degrees in roll direction
 3. Capable of being lifted by one individual
 4. Capable of being manufactured through common machine shop tools (CNC Mills, Lathes, 3D Printers)
2. Design digital user interface that allows user to control rotation of robot and flow of water
3. Program the robot to communicate between digital user interface and water valve, linear actuator, and stepper motor
4. Implement a thermal camera that will notify user of when a fire is nearby the robot

Project Results:

1. Successfully designed a robot that meets the design specifications of desired control methods (i.e. horizontal and vertical control of water turret, portable)
2. Successfully selected appropriate electronic parts to meet deliverables.
3. Successfully programmed robot that allows the user to control the water valve, stepper motor, and linear actuator
4. Successfully developed a digital user interface that allows the user to view surrounding area of the robot

Sponsors:

James Mokri, Mechanical Engineering Department of San Jose State University, Andrew Persuad

A Comparison of Thermal Performance between Photovoltaic and Solar Thermal Water Heating Systems

Student Team Members:

Forest Shaner
Trent Tanko
Long Wang
Ken Ng
Ryan Poon
Roy Gonzalez

Faculty Advisor: James Mokri

Project Scope and Objectives:

Compare the thermal performance of *photovoltaic (PV)* and *solar thermal (ST)* water heating systems in the context of residential water heating

1. Derive the governing equations
 1. Heat transfer rate
 2. Solar panel efficiency
 3. System efficiency
2. Design and build a testing apparatus to make a *fair* comparison between each system as they each heat a water tank
3. Program a data acquisition system in LABVIEW
4. Run experiments, process data in Matlab, and interpret results

Results:

1. ST *max & mean temperature* was greater than PV by a factor **1.8** and **1.6**, respectively
2. ST *heat transfer rate* was **4.7** times greater than PV
3. ST *solar panel efficiency* was **4.6** times greater than PV
4. ST *overall system efficiency* was **3.3** times greater than PV
5. ST performed better over shorter durations (~1 hour); however, PV is expected to reach a higher max temperature over a longer testing periods

Sponsor: None

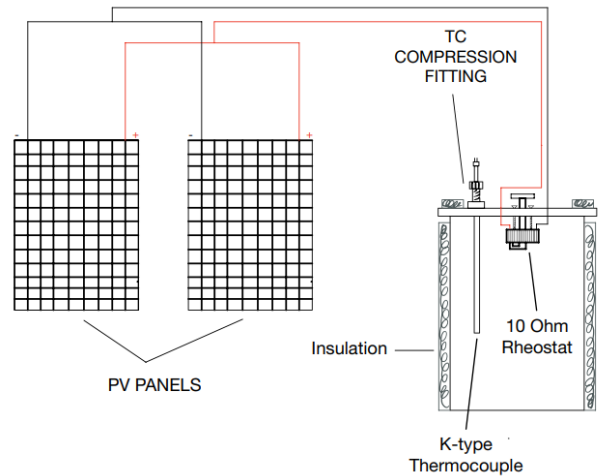

Solar Thermal System

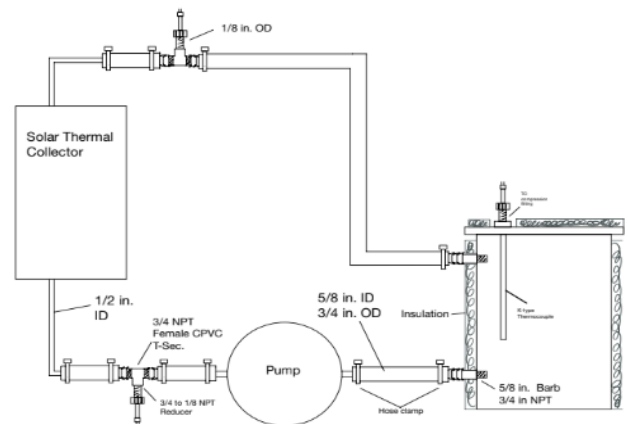

Mechanical Design and Programming of an Automatic EV charge Robot

Student Team Members:

Aris Delos Reyes II (Lead)
Quynh Tran
Truong Phan
Gene Ryan Pangan
Kenneth Lee

Faculty Advisor:

Professor James Mokri

Project Scope and Objectives:

An autonomous robot that uses image processing to follow a path. As the robot begins to move, a power supply cable tethered in a cable reel is released. Once the robot reaches the desired position (i.e. under the vehicle), the program sends a signal to the scissor lift to raise the inductive device to start the charging process.

1. Improve the line following code, the robot could turn at a sharper corner
2. Have the scissor lift operate once the robot is under a vehicle
3. Cable reel operate smoothly while the robot is moving

Project Results:

1. Successfully reassembled the chassis of the robot and installed the cable reel
2. Successfully defined the camera position and installed camera's supporters
3. Successfully remotely controlled the robot's motions
4. Successfully incorporated robot maneuvers with image processing process

Sponsor: Kevin Cameron

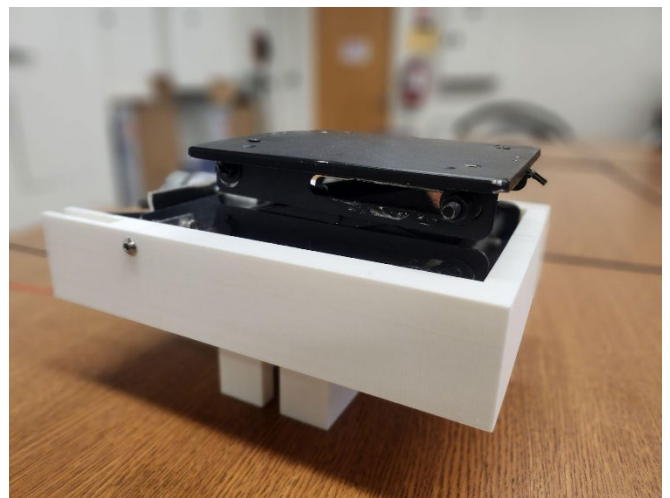
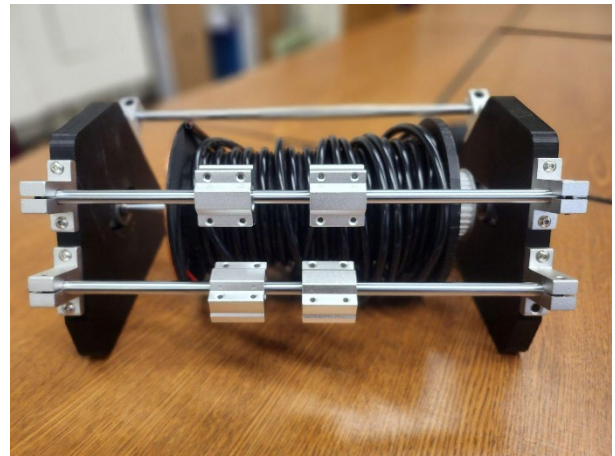
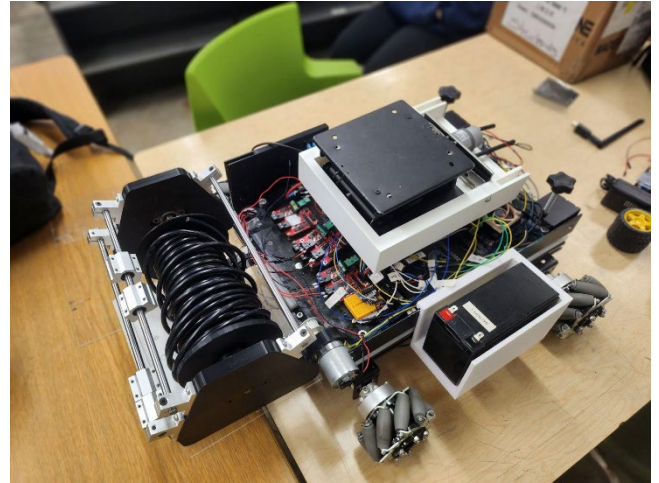

BaggerBot Mounting Apparatus and Bag Cassette

Student Team Members:

- Brian Flores
- Brandon Lenguyen
- Daniel Figueroa Garcia
- Derrick Li (Team Lead)

Faculty Advisor: Professor James Mokri

Project Scope and Objectives:

Make improvements to existing mounting apparatus.

1. Design a compact 4-bar linkage mechanism to move the feeder bot between stored and deployed positions.
 - o Accomplished by pivoting it upwards/downwards.
 - o Must fit within a 41 in. x 24 in. area and depth of 33 in.
2. Add torsional spring(s) to counter the weights of the feeder bot assembly and cassette for assistance in manual operation of the mounting apparatus.
3. Modify existing cassette to double bag capacity (from 500 to 1000 bags) by increasing cassette height, adding rear contour to accommodate bag taper, and incorporating spring-loaded follower to push bottom bags upward for vacuum to reach.

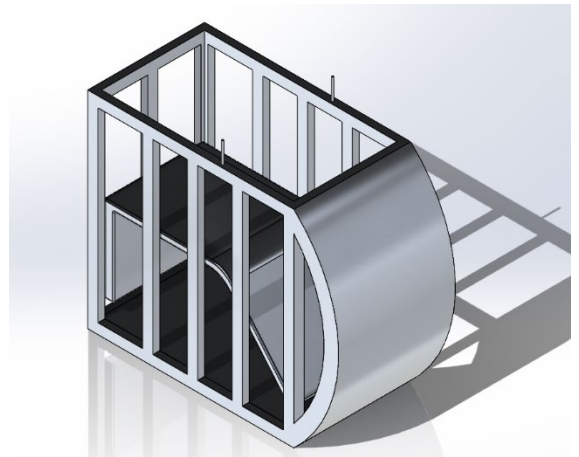
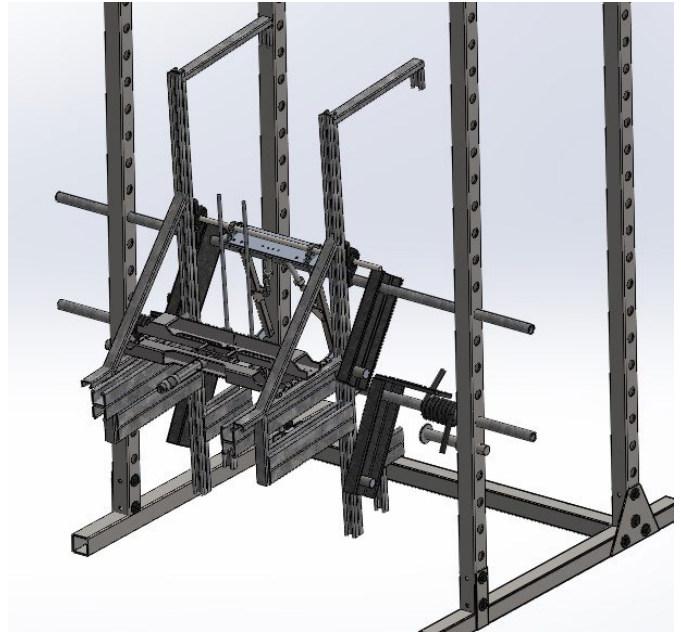

Project Results:

1. Prototype of both mounting apparatus and 1000 bag cassette designed.
2. FEA fatigue simulations provided a factor of safety of between 2.14-2.508 on the linkages
3. Acquired mockup of the BaggerBot superstructure to simulate usage.
4. Parts for mounting apparatus acquired, with cutting and welding in progress before assembly.
5. Frame of 1000 bag cassette being welded by the central engineering workshop.

Sponsor:

GoldenGate Mechanical

Waste-heat Recovery System using Organic Rankine Cycle (ORC) to Generate Electricity

Student Team Members:

- Olga Descalzi
- Emaan Haider (Team Lead)
- Trong Duc Think Nguyen
- Bikas Rattu
- Ervin Joseph Soberano
- Jessica Suarez
- Mijia Wen

Faculty Advisor: James Mokri

Project Scope and Objectives:

Design and build a working Organic Rankine Cycle with the waste heat produced from an Air Conditioning unit to generate electricity.

1. Finalize the best functioning organic working fluid.
2. Design a working Organic Rankine Cycle
 - a. Capable of handling a maximum pressure of 250 psi and temperature of 140 °F
 - b. A condenser estimated to handle 70 psi and a temperature as low as 60 °F
3. Identify required air conditioning materials for testing.
 - a. Additionally increase the efficiency of the air conditioning system by 20%.
4. Determining the auxiliary system to provide extra heat for our ORC system

Project Results:

1. Successfully determined a cost effective and organic working fluid to be R134a.
2. Successfully finalized the components for the ORC system which include a pump, turbine, two heat exchanger, and a condenser.
3. Successfully identified air conditioning materials for testing in order to have a fully functioning system between the Auxiliary, ORC, and AC systems.

Sponsor: Tom Burns, President of Golden Gate Mechanical

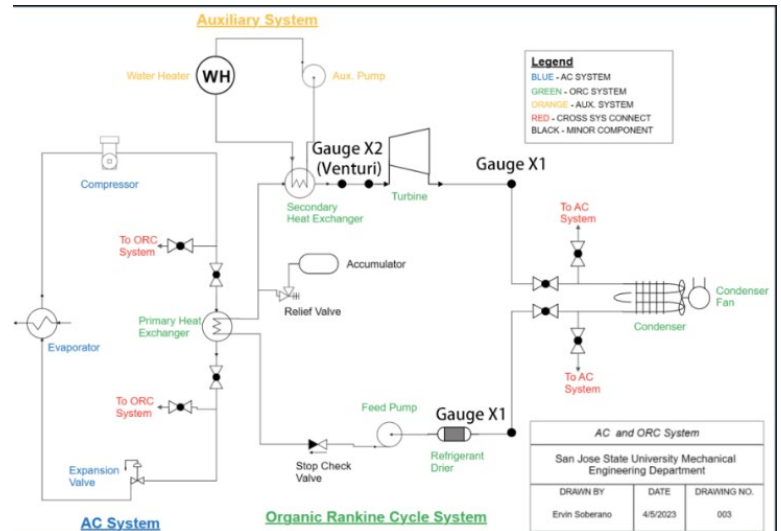

Maximizing Power of Bifacial Solar Panels Using Incident Angles, Forced Convection, and Reflective Grounds

Student Team Members:

Albert Navarro (Team Lead)

Justin Bagaoisan

Pedro Mendoza

Brian Le

Faculty Advisor: Dr. Syed Zaidi



Project Scope and Objectives:

Design and build a test rig for a bifacial solar panel to test its properties under different environmental conditions.

1. Obtain a family of IV curves for bifacial solar panels for different grounds.
2. Design a data acquisition system with the following specifications:
 1. Capable of cooling down panel using forced convection
 2. Capable of recording voltage, current, power, and temperature of panel throughout a day.
 3. Capable of fitting grounds underneath bifacial solar panel
 4. Capable of adjusting the angle in which incoming sun rays hit the face of the panel.

Project Results:

1. Successfully automated the process of obtaining voltage, current, power, and temperature readings from the panel.
2. Successfully created a rig with adjustable angles and sufficient height to fit grounds underneath
3. Successfully equipped design rig with solar fans to cool down the bifacial solar panel.
4. Successfully obtained data of how a bifacial solar panel generates power during peak sun hours.

Sponsor:

Intelliscience and HastestSolution

2D Traversing Mechanism with Plasma Torch and Live Camera Feed

Student Team Members:

Joel Bares (Team Lead)

Nhuan Nguyen

Van Le

Vu Tran

Faculty Advisor: Dr. Syed Zaidi

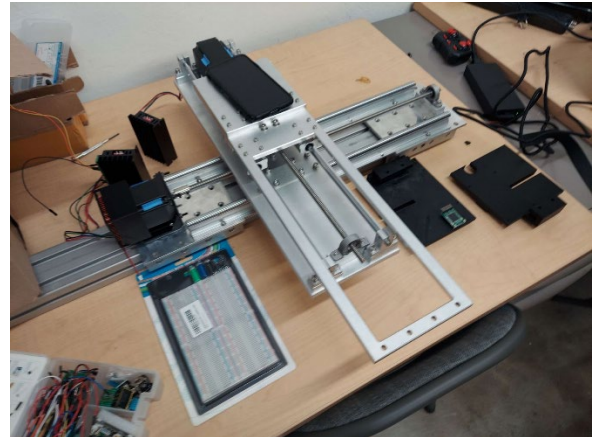

Project Scope and Objectives:

Design a 2D mechanism that will move an affixed plasma torch in tandem with a camera on a system controlled via MatLab and microcontrollers.

1. Design a framework consisting of intersecting rails and lead ball screws that will enable X- and Y-axis transversal motion.
2. Determine and select the optimal pair of stepper motor models to drive each set of rails to induce full axial motion.
3. Find MatLab-compatible microcontrollers and an image-processing-capable camera.
4. Design and complete a full circuit-microcontroller-computer system to use with the motors in order to enable full automated motion using a MatLab program.

Project Results:

1. Successfully designed and assembled the final mechanical system using CAD and machined parts.
2. Successfully acquired and implemented NEMA 23 stepper motors that are fully functional and drive the screws efficiently.
3. Successfully designed a mount that accompanies both the torch and a camera to ensure seamless simultaneous functionality during operation.
4. Successfully written an extensive MatLab program to control each individual task the system needs to fulfill.

Sponsors:

IntelliScience Institute

Investigation of a Novel Technique to Improve the 3D-Printed Parts Quality

Student Team Members:

Jackie Chang

Samantha Van De Graaf

Diego Soto Lopez (Team Lead)

Erick Vazquez

Faculty Advisor: Dr. Syed Zaidi

Project Scope and Objectives:

Our aim is to assess the quality of 3D-printed parts, and we are achieving this by attaching a DC motor to the nozzle head that runs at varying voltages to generate specific frequencies. The concept is that the optimal amount of vibration will fill gaps and layers between infill, enhancing the bonding between layers and improving the material's axial loading capacity. Furthermore, this method aims to enhance the tensile strength of a print using the same amount of material as in a print without vibration.

- Create a Motor mount to induce vibration to the nozzle head
- Video Inspection test
- Porosity Test
- Tensile strength test

Project Results:

1. We are able to conclusively see that adding vibration at varying frequencies was able to make 3D-printed parts less porous, thus increasing the part density without compromising printing time.
2. We are able to test and conclude that adding vibration at higher frequencies increases the tensile strength of 3D printed parts.
3. We are able to identify that by adding vibration we obtain miniature sinusoidal waves on linear parts.

Sponsor: San Jose State University Mechanical Engineering Department, Dr. Syed Zaidi

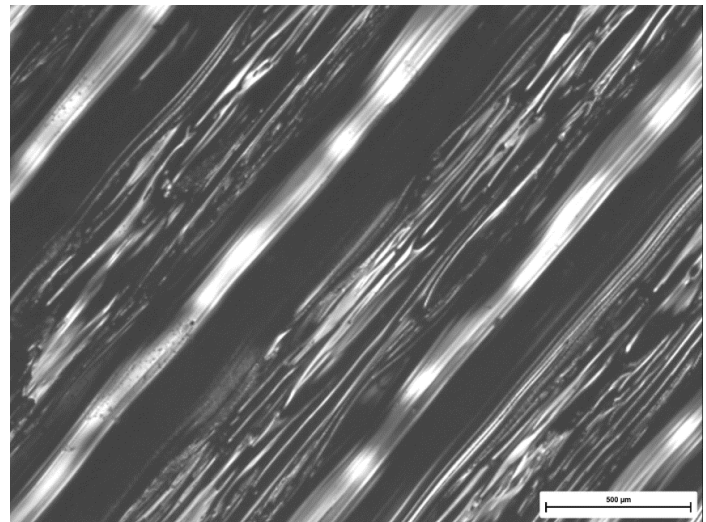
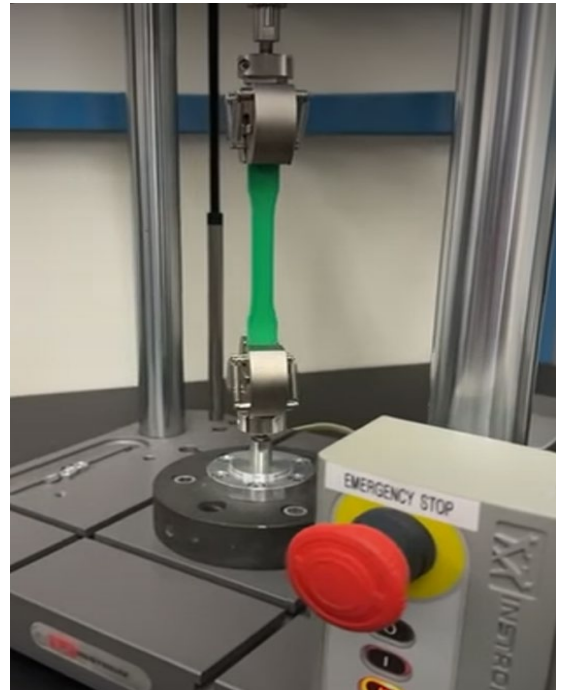

Plasma Hoover:

The design and development of a robot to mitigate surface bacteria using cold dielectric barrier diode (DBD) plasma.

Student Team Members:

Eric Chen, Andres Cisneros, Spencer Hight, Calla Lang (Team Lead), Kobe Lee, and Amanda Pansoy

Faculty Advisor: Dr. Sohail H. Zaidi

Project Scope and Objectives:

Design and develop a robot to mitigate surface bacteria to minimize contamination and reduce risks associated with alternative options.

Design and fabricate a robot, termed Plasma Hoover, that:

1. Traverse a room at 2-3 mph with a load of 65 lbs. when not operating plasma.
2. Move along an automated path or through remote control.
3. Supply and run a given amount of DBD torches with plasma for four minutes with onboard components only.
4. Traverse over surfaces infected with bacteria (*E. coli* k-12) in a controlled environment to measure the impact of the Plasma Hoover on bacterial growth.
5. Have a 360° range of motion, with a zero-turn radius.
6. Perform spectroscopic and bacteria testing and analysis on plasma and bacteria to provide proof of concept of the theory behind the functionality of the Plasma Hoover.

Project Results:

1. A robot was constructed, capable of
 1. Housing all required components so that operations could be independent of externally housed parts.
 2. Multidirectional movement through automated and remote control, capable of 2-3 mph unloaded.
2. Spectroscopic analysis was performed on the various plasma gas and shielding gas combinations.
 - a. It was determined that with a 1% volume Oxygen shielding gas addition, as opposed to plain Argon plasma, translational and electronic temperatures were unaffected, while vibrational temperature experienced a 20% reduction and rotational temperature experienced a 50% increase.
3. Bacteria tests were performed by passing Argon plasma and plasma with shielding gases over cultivated plates, with volumes of gas flow being 15 standard liters per minute and shielding gases being 5% of this total volume. 7 kV were used to generate cold plasma.
 - a. It was determined that there was a 63.99% reduction in colonies as a result of Argon plasma, a 68.71% reduction due to Argon plasma and Nitrogen shielding gas, and a 73.25% reduction when using Argon plasma with Oxygen shielding gas.

Sponsor: IntelliScience Training Institute, LLC

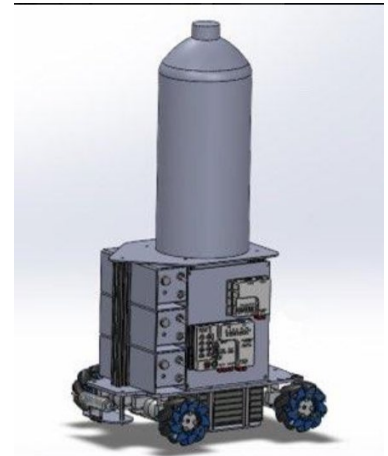

Characterization and Testing of a Bio-Leg Assistive Knee Brace for Leg Muscle Rehabilitation

Student Team Members:

Benjamin Chin (Team Lead)

Charles Kelzer

Alireza Khoshnevisakhlagh

Nancy Nguyen

Faculty Advisor: Dr. Sohail Zaidi

Project Scope and Objectives

Our goal is to design and develop a knee brace that utilizes electromyography (EMG) sensors and fluidic muscles to improve recovery time of patients undergoing leg muscle rehabilitation. To do this, we are incorporating fluidic muscles that mimic the same working principle as real muscle fibers to achieve a similar range of motion. The Bio-Leg is to be actuated by EMG sensors attached to the patient's leg which detect electrical impulses upon muscle activation. This grants the patient natural control over their weakened leg, rather than pressing a button for every activation cycle. The scope of our project encompasses design, optimization, and extensive testing of an assistive knee brace. Furthermore, our device should securely fit an individual such that a demonstration of the functioning Bio-Leg on a human leg can be conducted.



1. Design and assemble a mounting system that securely attaches the Bio-Leg to the patient's leg
2. Include multiple fluidic muscles and sensors to characterize performance:
 - Range of Motion
 - Actuation Time
 - Optimal Input Pressure
3. Mount the functioning knee brace on a human leg and conduct a demonstration

Project Results

1. Successfully designed and assembled a mounting system
2. Successfully conducted testing that characterizes the performance of the Bio-Leg
3. Successfully mounted the functioning knee brace to a human leg and conducted a demonstration

Sponsors

IntelliScience Training Institute

Preventing & Minimizing Thermal Runaway Passively: Phase Change Material & Heat Pipes

Student Team Members:

Janan Mirza
Jacob Penzo (Team Lead)
Sana Saleem
Carey Yip

Faculty Advisor: Dr. Sohail Zaidi

Project Scope and Objectives:

Design and build a testing apparatus to mimic the heat dissipation of Lithium-Ion battery cells within electric vehicles.

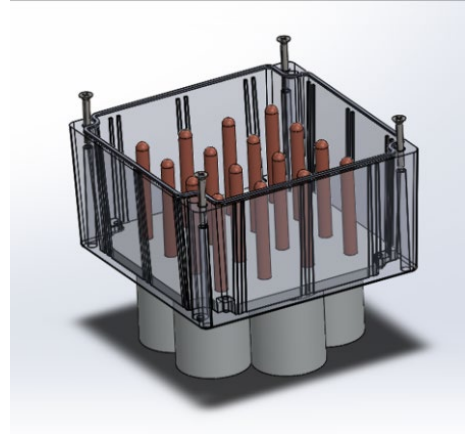

1. Design testing container and heater cells that will imitate the heating of an electric vehicle battery with the following specifications:
 1. Battery cells are comparable in shape and size to the Tesla 4680-cell battery.
 2. Reach the heat seen in a battery experiencing thermal runaway.
 3. Create an adiabatic testing environment to ensure all heat is accounted for.
2. Create a data acquisition system that will store temperature data from thermocouples placed within the testing container.
3. Run multiple experiments with various cooling techniques (PCM & Heatpipes) to determine the most effective technique.
4. Analyze the data to determine the effects of the cooling techniques.

Project Results:

1. Successfully designed and fabricated testing container and heater cells.
2. Successfully created a data acquisition system using a Raspberry Pi Pico board and thermocouples.
3. Successfully ran experiments that take in temperature data within the testing container with the use of various cooling techniques.

Sponsor:

IntelliScience Institute, SJSU Mechanical Engineering Department

Lockheed Martin Sponsored Robotic/Automated Isopropyl Alcohol Cotton Swab and Syringe Sterilizer Station

Student Team Members:

Jared Biesty	Emon Kandahari
Teddy Bullockus	Tien La
Sean Day	Gian Mendoza
Achint Jha	Raj Singh (Team Lead)



Faculty Advisors:

Professor Hussameddine Kabbani
Professor Lin Jiang

Project Scope and Objectives:

Design and build a station utilizing a 6-axis robotic arm (UR-10e) to sterilize cotton swabs and syringes.

1. Design and build table frame capable of holding UR-10e robot and various substations and mounting electrical box, robot control box, and pressure control valve.
2. Design cotton swab loading and dispensing station, agitation station, and drying rack.
3. Design syringe loading rack, cleaning station, separation station, and drying rack.
4. Design electrical schematic and implement a control box to enable power to all substations.
5. Design and implement a pneumatic system for use in various substations.
6. Create a programmable logic controller (PLC) program capable of controlling various substations based on sensor input and human machine interface (HMI) commands.
7. Create a robot program for moving cotton swabs and syringes between stations on PLC input.
8. Create graphical user interface (GUI) for human operators to monitor and control station.

Project Results:

1. Successfully designed and built table frame to hold station.
2. Successfully designed cotton swab stations.
3. Successfully designed syringe stations.
4. Successfully designed electrical schematic and constructed electrical box.
5. Successfully designed and installed pneumatic system.
6. Successfully created PLC program to control various substations.
7. Successfully created a robot program to move materials between substations.
8. Successfully created GUI for human operators to control station.

Sponsor:

Lockheed Martin Corporation

An Intelligent Robotic Walker for Assistive Care

Student Team Members:

Diego Andaluz (Team Lead)

Martin Ethan De Guzman

Cecily Sagiao

Faculty Advisor:

Dr. Mojtaba Sharifi

Professor Hussam Kabbani

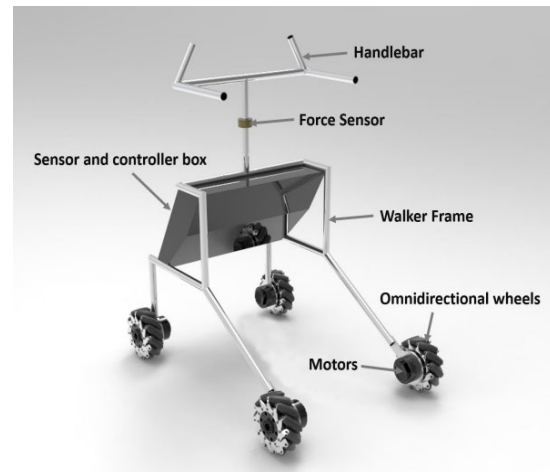

Project Scope and Objectives:

Our goal is to design and develop an automated walker that is able to provide ergonomic mobility for any user. We want to incorporate various sensors such as Lidar, RPLidar, and a force sensor. The force sensor would activate the entire mechanism and have the microcontroller operate the motors. The Lidar and RPLidar sensors will work in tandem to guide the mechanism in order to avoid obstacles in the user's path.

1. Design a walker that will allow the user to travel at a maximum speed of 2 m/s
2. Test and operate the sensors and have them communicate with one another and the motors
3. Attach the sensors onto the walker and connect them to the microcontroller
4. Conduct tests to make sure the walker is able to move and avoid obstacles

Project Results:

1. Having the sensor communicate and work together
2. Having the entire mechanism be mobile when applying force onto the force sensor

Sponsors:

San Jose State University, Charles W. Davidson College of Engineering, Mechanical Engineering Department

Electric Motor Conversion Module

Student Team Members:

Shehana Liyanage - Team Lead
Max Rothe
Andrew Stavrenos
Jonathan Olivares
Logan Kowalk
Maxwell Moeller

Faculty Advisor:

Dr. Hussameddine Kabbani

Project Scope and Objectives:

1. Design and build an electric module that would replace the internal combustion engine of a Ford 1988 truck using 6 electric motors.
 1. Capable of running 2 motors and housing 6 motors.
 2. Powerhouse fits in the engine bay (39 x 34 x 28 in3)
 3. Module must produce 600 Hp
 4. Team must manufacture module
2. Design an air cooling system to cool down the motors when any one of them reaches 115°C.
 - a. Measures temperature of motors in real-time using each motor's unique microcontrollers.

Project Results:

1. Successfully designed a complete electric motor module to house 6 motors.
2. Successfully designed mounts for cooling system.
3. Successfully built a complete control system.
4. Successfully machined module (161 fabrication hours)

Sponsor:

Micah Ranallo, Engineer at Zero Motorcycles

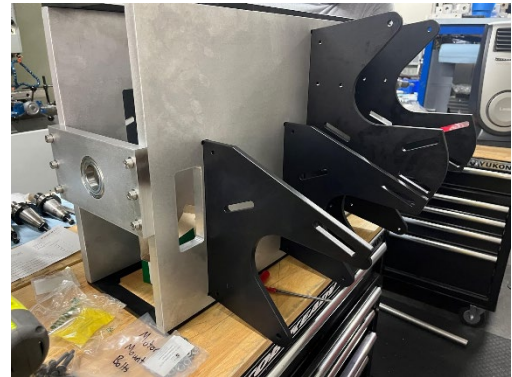
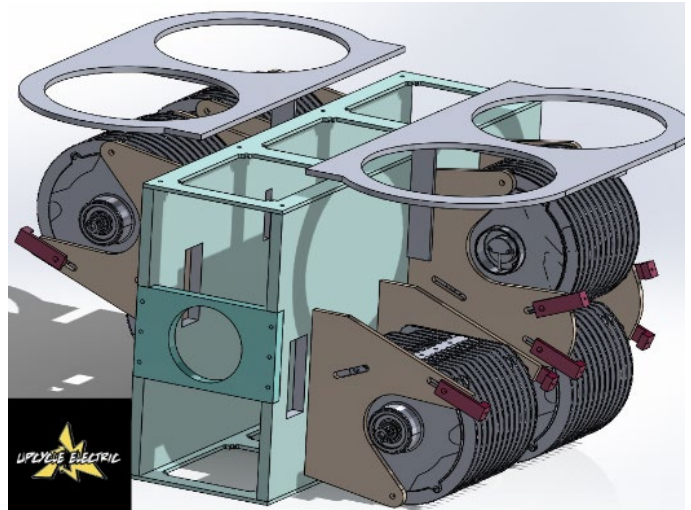

Cost-Effective and Smart Sensing Test Bed for Surgical Training

Student Team Members:

Lysette Zaragoza (Team Lead)

Joshua Billmann

Eric Barlog

Faculty Advisor:

Dr. Lin Jiang

Dr. Hussameddine Kabbani

Project Scope and Objectives:

Design and build a low-cost test bed for minimally invasive surgical training capable of providing feedback to the user.

1. Design and build sensors to measure pressure applied to tissue.
2. Design and build sensors to measure force applied by squeezing.
3. Develop processes to calibrate each type of sensor.
4. Fabricate a tissue pad emulating multiple types of human tissue.
5. Design an interface to visualize pressure and force data.

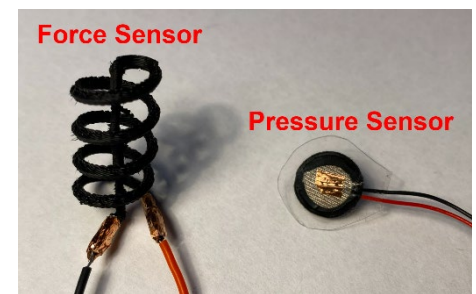
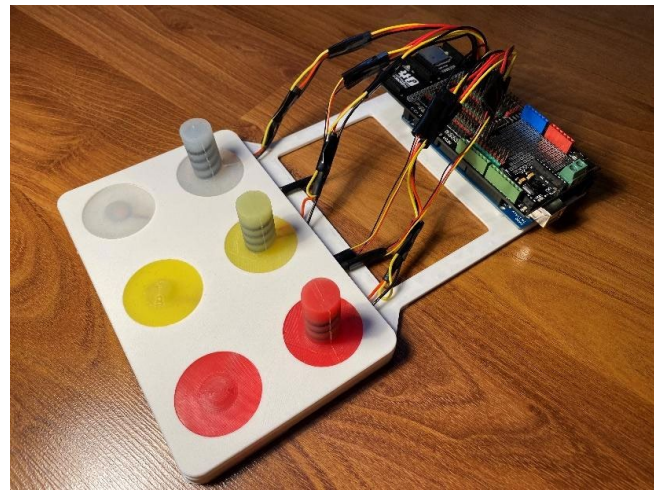

Project Results:

1. Successfully designed and fabricated piezoresistive pressure sensors.
2. Successfully designed and fabricated 3D force sensors using conductive TPU filament.
3. Successfully completed calibration of pressure and force sensors.
4. Successfully integrated sensors into silicone nodes of comparable stiffnesses to fat, glandular tissue, and vascular tissue.
5. Successfully created a visual interface over a live image feed in MATLAB to display pressure and force values and relative intensities at each node.

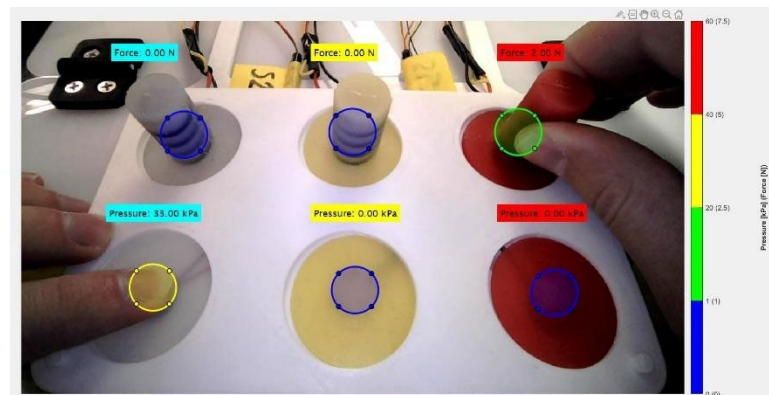

Sponsor:

McNair Scholars Program, SJSU College of Engineering Small Group Project Award

UNIFEED: Breast Milk Homogenizer for Optimized Nutrition Delivery

Student Team Members:

Santos Alvarado

Nate Preston

Beverly Wilt

Faculty Advisor: Dr. Lin Jiang

Project Scope and Objectives:

Design and build a test bench for homogenizing human breast milk in sanitary conditions.

1. Create a test bench with adjustable inputs, temperature, volume flow rate and ultrasonic driver frequency.
2. Simulate the ultrasonic driving of the milk to prove viability of design.
3. Design and build a test bench for research of milk homogenization:
 1. Capable of homogenizing human breast milk.
 2. Capable of maintaining milk temperature of 98 degrees Fahrenheit.
 3. Capable of being transported by one person with a platform truck.
 4. Reasonable size with easily interchangeable components so researchers can perform tests.

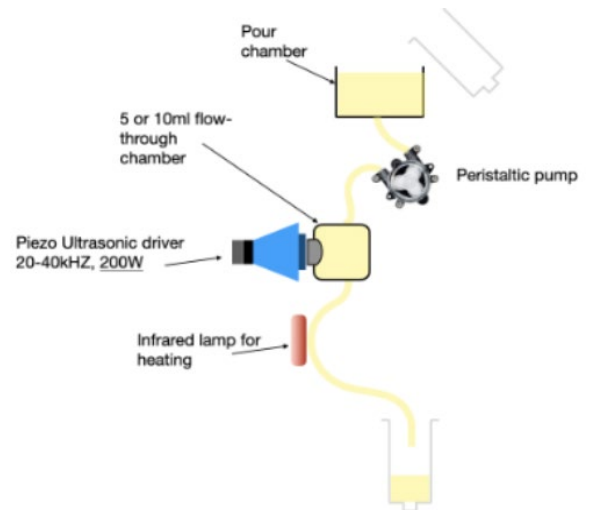

Project Results:

1. Successfully designed a peristaltic pump to achieve suitable volume flow for homogenization.
2. Successfully designed an ultrasonic probe for homogenization.
3. Successfully designed heat control system.
4. Successfully implemented a microcontroller to operate the system.
5. Successfully conducted tests to determine the degree of homogenization capable of being achieved with current device design and propose optimization strategies.

Sponsors:

Kyzen LLC